

THINK.
ADVANCE.
DESIGN.

120 years
Galletti



PRODUCT
CATALOGUE 2026



Think. Advance. Design.

Think. Advance. Design.

With 120 years of history behind us, we design and manufacture solutions that include systems, services, and tools for air conditioning in the commercial and large residential sectors.

Today, we look to the future by adopting a new approach to design in our industry, Advanced Design.

We design in co-design with the customer, and every new solution is born from the collaboration between technical expertise, creativity, forward-looking vision, and synergy with experts from different fields, with the goal of anticipating trends in the HVAC sector.

What we mean by Advanced Design:

We study how the environment and the context in which we operate may evolve over time. This allows us to understand how these scenarios could impact our specific sector and to anticipate future trends. The collection of this information and the formulation of these scenarios are also made possible thanks to our long-standing collaboration with the University of Bologna.

We collaborate with experts from different fields, promoting dialogue and cross-fertilization of ideas, and actively involving the customer in the analysis and development of tailored solutions. This dynamic and open approach allows us to access a broad range of knowledge and perspectives and to develop solutions that are increasingly technologically advanced, high-performing, highly customizable, and aimed at reducing their environmental impact. In addition to the technical features of our solutions, we also focus on how they can best integrate into the context in which they will be installed.

We examine materials, processes, and supply chains to further reduce the environmental impact the company generates in terms of resource use and waste production. Beyond this, we are committed to providing increasing support to local cultural and social initiatives, contributing to the growth and development of our region.





A path in continuous evolution

Behind us, 119 years of history and tradition; ahead of us, a path oriented towards Advanced Design where the person is increasingly at the center of our solutions.

For us, this means designing the future.



1906

ESTABLISHMENT

Ugo Galletti opened a small iron works factory and workshop for repairing agricultural equipment in Castel Maggiore, a town located near Bologna.

1920

COLD IS IN ITS DNA

The company began its expansion by specializing in the production of ice-making moulds.

1930

GROWTH

Galletti became an enterprise with more than 100 employees, working sheet metal as a subcontractor.

1950

THE WAR AND LARGE WORK ORDERS

It was the job of Ugo's sons, Fiorenzo and Luigi Galletti, to organize the recovery, with work orders from such prestigious companies as Ferrari, Lamborghini Trattori, Ducati, Landini, and Ferrovie dello Stato. Galletti also began manufacturing motorcycle chassis.

1960

THE BOOM YEARS

Galletti ceased being a subcontractor and entered the heating market with its own brand.

1970

FRESH AIR

A new range of products for air conditioning. After the heating sector, Galletti achieved great success in the air-conditioning market with its Polar Warm fan coil unit.

1980

WINDS FROM JAPAN

A partnership was established with a large Japanese air conditioning manufacturer. Galletti became the exclusive distributor for Italy of domestic split air conditioners. In 1982 the company moved to its current location in Bentivoglio.



1994

EUROVENT CERTIFICATION

Galletti obtained Eurovent certification for all of its products. A guarantee of quality and reliability.

2006

THE CENTENNIAL

The company celebrated its 100th year, and under the leadership of its CEO Luca Galletti, it confirmed its position as a leader in the market for hydronic indoor units and chillers.

2014

THE GROUP

The Group reached its full size of 8 different companies with 8 production plants, offering a comprehensive package of finished products and services in the HVACR sector.

2020

NEW CLIMATIC CHAMBER

Inauguration of the new climatic chamber for testing medium and high-power heat pumps and chillers, which rounded out one of the most advanced R&D departments in the sector, confirming the company's strategic choice of continuous growth regarding highly complex solutions and systems.

2021

ENVIRONMENTAL CERTIFICATION

Galletti obtained UNI EN ISO 14001:2015 Environmental Certification.

2024

ADVANCED DESIGN: A NEW PATH TOWARDS THE FUTURE

We analyze materials and processes, promoting the exchange of ideas with experts from various fields to develop technologically advanced, high-performance solutions with low environmental impact. EPD certification: (Acqvaria, Acqvaria i, VIs).

2025

SUSTAINABILITY REPORT

Galletti publishes its first sustainability report and obtains gender equality certification.

Three strategic processes

The great strength of Galletti, as well as of all the other Group companies, is that of continuing to maintain internally **the 3 strategic processes** which are the pillars of every new solution.

1

Research and development

The market requires products that are increasingly on the cutting edge for quality, performance, and energy efficiency.

In order to satisfy this demand, Galletti has been relying for decades on a modern in-house R&D department. This department is a vital part of the company; it works in close cooperation with Production and Quality Control to guarantee a product that has been studied in the smallest detail.

The constant desire to improve the product is matched by the need to refine the research and development techniques.

The company possesses a calorimetric chamber for the hydronic indoor units and two climatic chambers for the chillers, and it is one of the few companies in Italy to possess a reverberation chamber for measuring true sound levels.

Design

That which is developed, conceived, and analyzed in the R&D Department then takes shape in the Engineering Department, which handles the mechanical and electrical design of the hydronic indoor units, chillers, and heat pumps.

The Engineering Department's dedicated team handles the development of software and hardware solutions; unlike their competitors, this activity allows the company to make proposals to the market that are open to its customers' requirements.

2

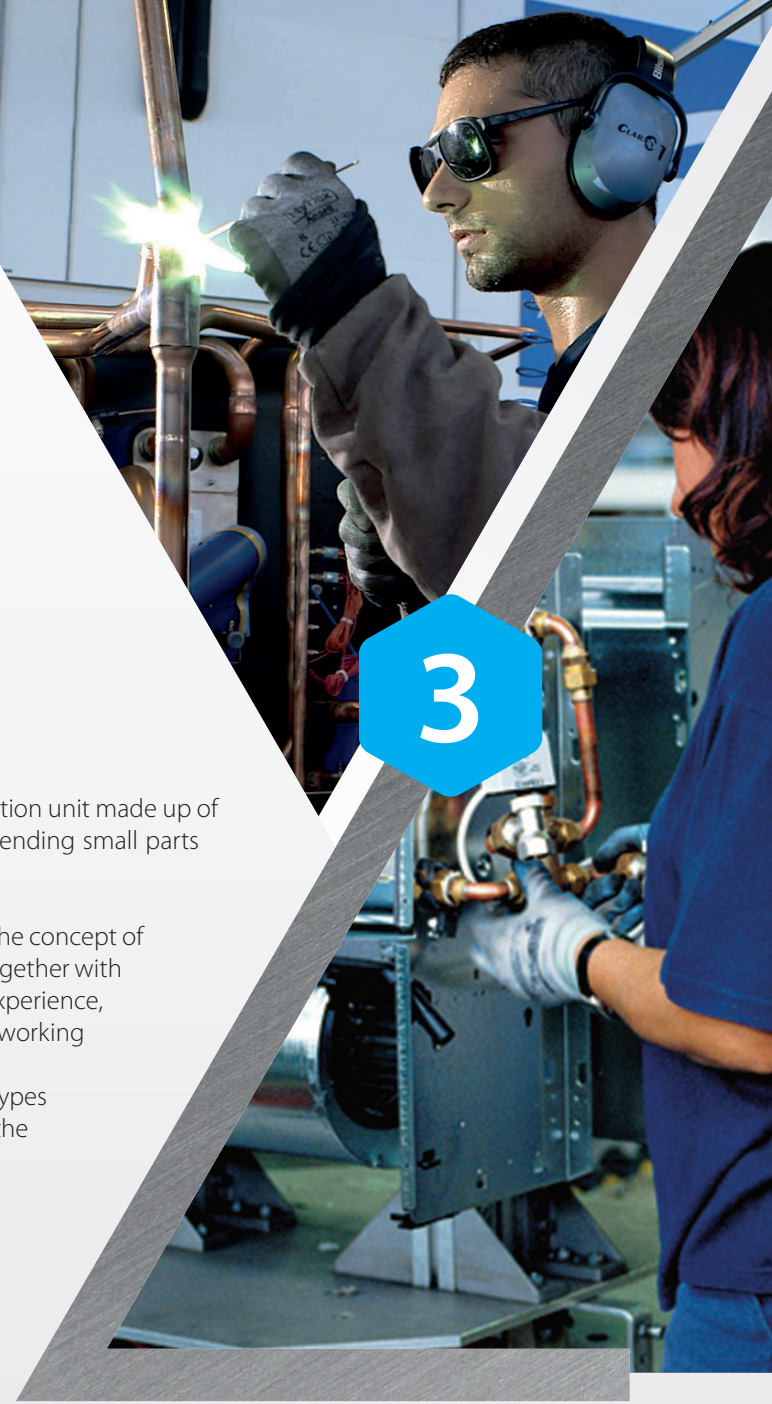

Vertical production

The automated sheet metal work centre is a cutting-edge production unit made up of a system which integrates an automatic magazine, a robot for bending small parts and punch and bending stations.

This latest generation system represents a clear example of what the concept of “verticalization” means for Galletti: galletti’s important expertise, together with its considerable production flexibility, are the result of not only experience, but also of the ability to internalize strategic processes such as working sheet metal.

To this must be added the management of two other important types of processing: the in-house production of heat exchangers and the in-house development of adjustment hardware and software.

The approach of developing, designing, and producing in-house semi-finished products, components, and finished products strengthens Galletti’s ability to be flexible regarding its customers’ requirements and gives a large competitive advantage over the other players in the market.

All this translates into an **Integrated Production Unit** where the automated warehouse and machining centers converge into a single synergistic process of automated punching and bending. Designing and producing every component ‘in-house’ means transforming quality control into a made-to-measure response for our customers.

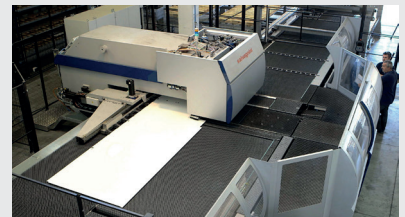
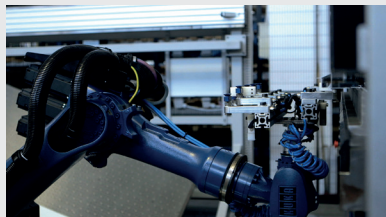



Climatic Chamber

Great precision for great capacities

The new climatic chamber at the Bentivoglio Galletti plant represents the company's commitment to invest in the accuracy of its claimed performance, due to the possibility of testing the units under actual operating conditions.

The tests can be conducted on either chillers and heat pumps or multi-purpose units and free-cooling units up to a rated cooling capacity of 600 kW, representing a benchmark for R&D Department activities and an important technological milestone for the company.

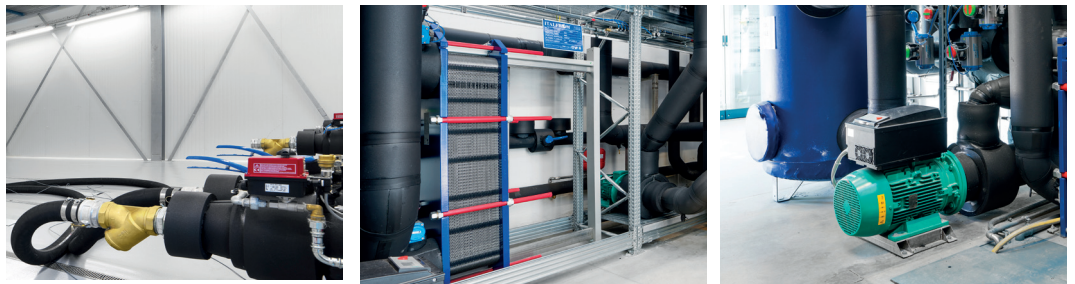

A cutting-edge system

Thanks to the three independent test circuits and the more than 100 sensors positioned between the testing room and the rest of the system, this chamber is the ideal instrument for monitoring the thermal, electrical, and acoustic performance of the chiller units.

The advanced hydraulic system allows the units' condensation heat to be dissipated with the assistance of three 5000-liter storage systems and a water-water cooling unit manufactured by Galletti connected to a dry cooler. The actual behavior of the system in the heating mode is simulated thanks to the addition of a further storage tank to mitigate the negative effects of the defrosting periods.

Test conditions can vary within a very wide temperature and humidity range (-20 - 55 °C ambient temperature; 20 - 95 % relative humidity), and the unit can be tested by simulating partial-load operation with or without the presence of glycol in the system. The latter can be recycled and used again in subsequent tests.





Climatic chamber

Accuracy of the measurements

The structure of the chamber and all of its components have been designed and selected in order to achieve the best possible measurement accuracy and in accordance with the main reference standards.

The probes used for temperature regulation have class A accuracy, while the sensors used for the measurements on the unit being tested have a degree of accuracy of 1/10 DIN, which is able to keep the measurement error within ± 0.03 °C.

In addition, each test circuit is equipped with different capacity flow meters to guarantee the correct measurement of the flow rate for units of different capacity.

The chamber has an internal volume of about 800 m³, and has been designed to guarantee dimensions and air speeds (< 1.5 m/s) that make it possible to meet the requirements of Standard UNI 9614 for the measurement of noise emissions, while monitoring the ambient air and produced water temperatures. Galletti's Climatic Chamber has achieved the important recognition of Eurovent Approved Laboratory.



This logo indicates the EOC recognition of the laboratory. It does not constitute certification of tested products or performance. Regarding Galletti products, the company has adhered to the Eurovent certification program with its entire catalog since 1994, following the "Certify all" principle.

Viewed tests and performance reports

An automatic system supervision and control software program developed in the Lab VIEW environment makes it possible to reach the stability conditions defined by Standards EN 14511 and EN 14825 under the desired test conditions. The acquisition system then begins recording the data, and at the end of the procedure a summary report is prepared that can be sent to the customer by e-mail. The entire test procedure can be viewed on site or remotely using a video camera.

In this manner, a customer that would like to carry out a viewed test can monitor the unit's main operating data under the actual design conditions, such as:

- Power delivered
- Temperature of water produced
- Water pressure drop
- Water flow
- Electricity consumption and time efficiency





Directive 2009/125/EC and 2010/30/CE

The European Council has approved the 2030 climate and energy framework which sets three main objectives for its member states:

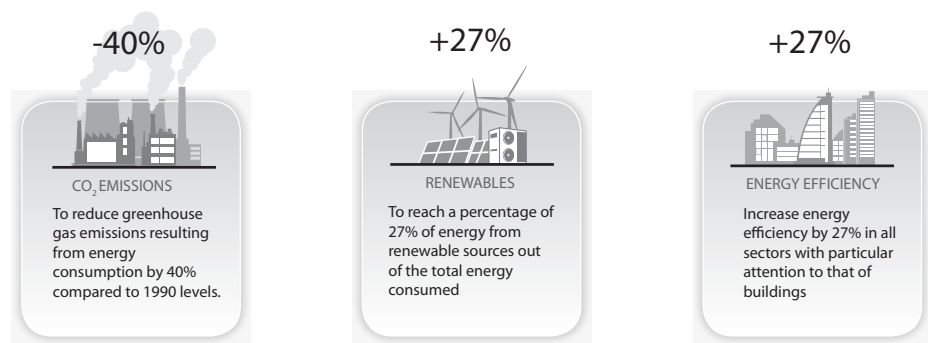

To achieve these goals, the EU has adopted the ErP directive 2009/125/CE (Energy-related Products), which regulates the eco-design requirements for all energy-using products and directive 2010/30 / EC on energy labeling. There are three main European regulations that lay down the rules for the application of Directives 2009/125/EC and 2010/30/EC:

- » 813/2013;
- » 811/2013;
- » 2281/2016.

The seasonal energy efficiency of heating space η_s is calculated as the seasonal efficiency coefficient SCOP divided by the conversion coefficient CC, corrected for the contributions in relation to the temperature controls (F1) and for the water/water heat pump units for the consumption of one or more groundwater pumps (F2).

The coefficient for conversion of electricity into primary energy was considered equal to $CC = 2.5$.

$$\eta_s = SCOP / CC - F(1) - F(2)$$

The calculation for the seasonal energy efficiency of cooling space $\eta_{s,c}$, which derives from SEER seasonal efficiency, is the same.

$$\eta_{s,c} = SEER / CC - F(1) - F(2)$$

Regulation 813/2013 applies to heat pumps with a rated capacity of less than 400 kW. For this range of capacities, minimum requirements for sound power level and seasonal energy efficiency are defined.



Directive 2009/125/EC and 2010/30/CE

The latter index must not be less than the following values:

SCOP ⁽¹⁾	Air-water	Water-water
Combined heat pumps and heat pumps	2,83	2,95
Low temperature heat pumps	3,20	3,33

Regulation 811/2013 applies to heat pumps with a heating capacity of less than 70 kW. Manufacturers are required to highlight the energy label on the unit and to specify the energy efficiency class on all technical and commercial materials.

Regulation 2281/2016 applies to chillers with cooling capacity up to 2000 kW and reversible heat pumps with cooling capacity between 400 and 2000 kW. For this range of capacities, minimum requirements for seasonal energy efficiency are defined; in fact, since January 1, 2021, the manufacturer cannot place units on the market with SEER values less than the following values:

SEER ⁽¹⁾	Air-water	Water-water
Chiller with PC<400 kW	4,10	5,20
Chiller and reversible heat pumps with 400≤PC<1500 kW	4,55	6,50
Chiller and reversible heat pumps with 1500≤PC<2000 kW	4,55	7,00

Scope of Regulations 813/2013 and 2281/2016

	Applied regulation
Chiller with 0≤PC<2000 kW	2281/2016
Reversible heat pumps with PC<400 kW	813/2013
Reversible heat pumps with 400≤PC<2000 kW	2281/2016

The ErP directive involves and strongly influences the design of all our products Galletti, further stimulating the continuous pursuit of excellence, in terms of performance and reduction of the environmental impact.

Compliance with the regulation is not a classification of merit or an efficiency class, but rather an indispensable requirement for CE marking, without which the product cannot be placed on the EC market.

(1) Bin profile according to UNI EN 14825



Galletti started out on the road to certification in 1994, the year in which the company entered the Eurovent program for fan coils, later followed by chillers and heat pumps.

Galletti actively participates in the Eurovent Certified Performance (ECP) Certification Programmes for Fan Coil Units (FCU) and for Chillers and Heat Pumps (LCP-HP).

Eurovent is a European authority that guarantees the energy, aeraulic, and efficiency performance of the products of the companies that are enrolled in its programs. It is based on the "Certify all" principle; therefore, participants are required to declare the performance of all their products included in a specific certification program, which, in this sense, represents a "guarantee of quality and professionalism" of the company itself.

Regarding management systems, the journey began in 1999 and, in 2000, saw the certification of its quality system in accordance with the UNI EN ISO 9002:1994 standard. In the following years, Galletti adapted its management system to the new standards: first the UNI EN ISO 9001:2008 and then, subsequently, the UNI EN ISO 9001:2015.

In 2003, the adaptation of its quality system and the continuous improvement of processes allowed the company to be certified in accordance with Directive 97/23/CE (PED), subsequently amended by 2014/68/EU (PED).

In 2009, the company embarked on a journey that led its management system to certification in terms of occupazionale health and safety OHSAS 18001:2007 and, subsequently, to the new UNI ISO 45001:2018 standard.

Since 2012 Galletti has been in compliance with European Regulation no. 2015/2067/UE which makes F-GAS certification mandatory for companies that manufacture stationary refrigeration, air conditioning, and heat pump equipment containing fluorinated refrigerant gases. This certification ensures that operators are refrigeration technicians with specific expertise in protecting the environment, such as the reduction of refrigerant gases emissions into the atmosphere.

In 2025, Galletti continues its journey of innovation and continuous improvement by implementing its system with a new **Integrated Systems Policy** and introducing a **Policy dedicated to Gender Equality**, a step that reflects the company's commitment to building an increasingly inclusive and equitable work environment.

Our Certifications:

- **ISO 9001**
- **ISO 14001**
- **ISO 45001**
- **PED**
- **F-GAS**
- **PdR125 – Gender Equality**
- **ISO 14064-1 – Carbon Footprint**
- **EUROVENT**
- **ECOVADIS Bronze**
- **ETL, certification for the American market**

To view all official certification documents: galletti.com



Environmental certification

As part of Galletti's increasingly wide-ranging and constantly evolving certification system, a further important milestone was reached in December 2021, namely the obtaining of environmental certification in accordance with the standard UNI EN ISO 14001 : 2015.

This certification demonstrates our determination to uphold our corporate values, including the continuous improvement of our environmental performance and our focus on policies for sustainability.

For Galletti, environmental certification is just a starting point, and every day the company is committed to setting objectives, attaining them and then setting new ones that are ever more ambitious.

In December 2025, the UNI EN ISO 14064-1:2019 Certification (Carbon Footprint) was obtained.

Environmental Product Declarations

After obtaining Environmental Certification, EPDs (Environmental Product Declarations) were published for the Acqvaria and VLS products.

Galletti's path is clear: the company's daily effort must be focused on becoming increasingly virtuous in developing high-quality products that meet our customers' needs while protecting the well-being of the planet to an ever greater extent.





Year after year, Galletti has continuously renewed its Bentivoglio facility by investing in the reorganization of production lines, in new Research & Development areas, and, naturally, in new buildings and offices. Since 2010, the company has relied on its own **photovoltaic system** which, in 2025, was expanded with the goal of self-producing all the electricity it consumes. The new system, with a peak capacity of **600 kWp** and an annual electricity output of around **646,920 kWh**, adds to the existing **944 kWp** installation, which had an annual production of about **900,000 kWh**.

In 2025, Galletti S.p.A. publishes its first **Sustainability Report**, marking a key moment in the journey towards a more responsible and regenerative industrial model, aimed at drastically reducing climate impact and protecting human rights within our corporate context, supporting our society and our territory. In this context, **efficiency is no longer just a competitive lever**, but a **duty towards the environment, people, and society**.

For this reason, Galletti works daily to optimize the product lifecycle, investing in low-impact technologies, certified materials, inclusion, and training, promoting safe, fair work environments that respect the dignity of all collaborators and partners. The report recounts the company's commitment, the goals achieved, and those that will guide it in the long term.





We were born with a clear intention to bring to life something absolutely new and unique. Today, we continue to work with a forward-looking vision to build innovative solutions together, increasingly oriented towards energy and environmental sustainability.

The Group has its roots in **Galletti Spa** and in the intuition of a **select pool of successful managers** in the air conditioning sector who, starting from **1995**, shaped a unique reality, creating new companies from scratch and acquiring others. **Galletti Group is today one of the very few entities still entirely Italian-owned** and boasts **several brands** within, each with its own specialization in the sector.



It is the Group's reference brand specialized in the production and sale of **hy-dronic terminals, chillers, and heat pumps** for residential and commercial applications.



A historic brand on the market, Cetra is today the company within the Galletti Group that **leads the air treatment** market for the residential and tertiary sectors.



Company focused on **process cooling** which, thanks to more than thirty years of expertise, **offers tailor-made solutions** to meet the specific needs of its customers.



Company providing **maintenance and technical support services and after-sales support** for the Galletti brand products.

The great strength of the Galletti Group, in all these years, has been to **continue to keep the strategic processes** that are the pillars of each new solution internally: **Research and Development, Design and Production**. The in-house development and design of semi-finished products, components and finished products guarantees extreme flexibility towards customer requests.



On-line configuration software

Galletti has developed on its www.galletti.com web-area the new ON-LINE integrated platform for selection, configuration and the making of the economic offer of products. The software, whose use is easy and intuitive, allows the identification of the desired products by calculating their performances based on real working conditions and their configuration helping the user in choosing options and accessories. It also allows to obtain a detailed report which includes performances, dimensional drawings, tender specifications and the economic offer.

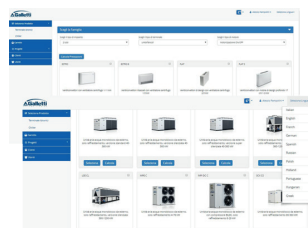

Product selection:

- » Filters to make the identification of the requested product easier
- » Performance calculation and saving of results
- » Performance comparison between products belonging to different series

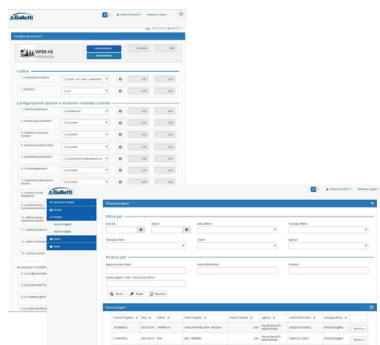

Configuration and project history

- » Wizard configuration of accessories and options for chillers, heat pumps and hydronic units
- » Creation of a project which collects all products of interest
- » Complete management of the stored history projects



Report:

- » Generation of a detailed list report in pdf format
- » Choice of the sections to be included in the print:
 - Products performances
 - Dimensional drawings
 - Tender specifications



CATALOGUE with multimedia elements

In everyday life, we now consider smartphones and/or tablets to be indispensable tools that we can't live without. Being able to take advantage of their features also for reading our catalogue seemed to us to be a truly innovative solution, as well as a considerable advantage. This is why we have developed a section of our catalogue with elements that can "come to life" and provide an experience that goes far beyond a simple printed photograph.



What can you find in this catalogue?

Inside the product catalogue, you will find QR CODES marked by the purple icon shown here. Once you scan the code, by opening the camera or using a specific application for reading QR CODES, some multimedia content will be played on the device used (smartphone or tablet).

The multimedia content, mainly product or corporate videos, are uploaded on Galletti's YouTube channel. Don't forget to follow us on all our other social media channels: LinkedIn and Instagram.

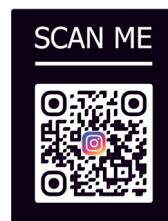

Follow us and share!



GH Service

ghservice.it

Galletti has always considered service to be of fundamental importance in order to provide an all-around range of offerings to its customers. For this reason it created GH Service specialized service provider.

GH Service is at the customer's disposal from the design stage to the after-sales period; it operates through an extensive network of more than 100 service centres, which provide support to the numerous sales agents and distributors in Italy and around the world.

Galletti after-sales service is equipped and competent to service all types of air conditioning units, whether designed for the comfort or tertiary sectors, for processing machinery or technological environments, air handling units or highly customized units, its primary aim being customer satisfaction.

The company's internal and outsourced staff are highly qualified, have long-time technical experience and are kept constantly up to date through specific refresher training courses. Its specialized technicians are in possession of all necessary certifications for operating on refrigeration cycle units and are equipped with cutting-edge tools.

GH Service is able to provide its customers various services and opportunities meeting a multitude of demands while providing highly customized services.

- » System startup
- » Trouble shooting
- » Management and sales of spare parts
- » Routine and special maintenance
- » Telephone customer support systems
- » Assembly of units at worksite
- » Disposal of obsolete units
- » Guaranteed sale of used units
- » All-inclusive rental

In a market where simply selling a product is no longer enough, Galletti, thanks to GH Service, presents itself as a single partner able to provide a comprehensive range of products and services.

FOR RENT



Chiller unit and heat pump rentals: an additional service for Galletti customers

Galletti's comprehensive range of products and services Galletti has been further expanded with a new service that meets the new needs of HVAC professionals.

In recent years there has been strong growth in the use and consequent demand for Chiller unit and Heat Pump RENTALS. This approach was developed to maintain comfort conditions or solve technical problems in specific applications where, due to the limited duration of the required service, the type of system, or the production activity carried out, the traditional purchase of a unit is not the best option.

Being able to quickly replace a unit and thus guarantee continuity of service and being able to air-condition a room for a limited period of time are requirements that prove to be increasingly appreciated year after year.

Galletti, thanks to its leadership role in the field of air conditioning for the service industry and in the field of refrigeration in the context of processes, is now adding a new chiller unit and heat pump rental service to its already extensive range of products and services.

Thanks to our partnership with a leading national company providing rental solutions for sectors such as trucks, cranes, worksite logistics, and earthmoving, Galletti offers the most suitable rental units for specific applications, such as:



Hotels and the hospitality industry

units for handling emergency situations and ensuring guests' comfort



The winemaking industry

units for covering cooling requirements during the winemaking process that do not normally last beyond 2 months



The large-scale retail sector

units for the correct conservation of goods stored in warehouses



Non-permanent trade shows and events

units for air-conditioning tensile structures, industrial buildings, and facilities that host summer or winter events



Production processes

units designed for industrial applications that require a temporary solution due to an unexpected breakdown



Greenhouses

specific units for the air conditioning needs related to plant cultivation in a controlled environment

The units offered by Galletti through the rental service represent the state of the art in terms of efficiency, quiet operation, performance, and sturdiness, ensuring that the customer will have a suitable solution providing optimum levels of comfort that meets their needs, including installation and testing of the units carried out by Galletti specialized technicians and careful checks when the units are returned.

Therefore, professionals in the industry can now easily find quality, reliability, and professionalism – the qualities that have made the Galletti brand famous worldwide – even using this new rental service.

TABLE OF CONTENTS

FC - Hydronic indoor units



ART-U pag. 28
Design fan coil unit with a minimum depth of 10 cm only and EC motor
1 - 4 kW



ART-U Canvas pag. 34
Design fan coil unit with a minimum depth of 10 cm only and EC motor
1 - 4 kW



ESTRO pag. 38
Fan coil units with centrifugal fan
1 - 11 kW



ESTRO i pag. 50
Fan coil units with centrifugal fan and EC motor
1 - 9 kW



FLAT S pag. 56
Fancoil with design cabinet, with a depth of 17 cm
1 - 3 kW



FLAT S i pag. 60
Fancoil with design cabinet with a depth of 17 cm, and EC motor
1 - 3 kW



FLAT pag. 64
Design fan coil units with centrifugal fan
2 - 5 kW



FLAT i pag. 68
Design fan coil unit with centrifugal fan and EC motor
2 - 5 kW



CFV pag. 72
Recess-mounted fan coil with formwork
1 - 4 kW



GHW pag. 76
High wall-mounted fan coil units

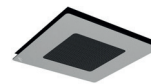

EFFETTO pag. 80
Design module for air intake and diffusion with the Coandă effect



EFFETTO AirClissi pag. 82
Coandă effect illuminated module

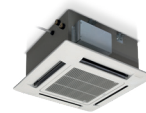

ACQVARIA pag. 84
Cassette fan coils
3 - 10 kW

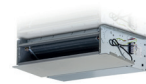

ACQVARIA i pag. 90
Cassette fan coils with EC motor
3 - 10 kW

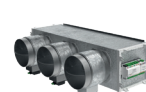

FHP pag. 96
High available head duct fancoil units
1 - 4 kW



DMP pag. 102
Wired Plenum with Motorized Dampers



DUCTIMAX pag. 106
Medium-head ducted units
2 - 8 kW



DUCTIMAX i
Medium available head
duct units with EC motor
2 - 8 kW

pag. 112



UTN i
High-head thermal
ventilating units
with EC motor
4 - 18 kW

pag. 126



UTN
High-head thermal
ventilating units
3 - 23 kW

pag. 118

FH - Fan heaters



AREO
Fan heaters with ON/
OFF electric motor
8 - 101 kW

pag. 134



DST
Air destratifiers
1700 - 9100 m³/h

pag. 148



AREO i
Air conditioning fan
heaters with EC motor
19 - 62 kW

pag. 144

CO - Controllers and software for indoor hydronic units



EVO-2-TOUCH
Touch screen
display interface

pag. 156



MYCOMFORT
Electronic microprocessor
controller with LCD display

pag. 162



EVO
Electronic microprocessor
controller with remote
user interface

pag. 158



TED
Simplified electronic
controller

pag. 164



EVO DISP
User interface with
LCD display

pag. 159



EVO LINK
Monitoring system with
5" touch screen for the
air-conditioning system

pag. 165



GALLETTI APP
Indoor unit control
application for
smartphones

pag. 160

TABLE OF CONTENTS

AW - Air chillers and heat pumps



MPE
Outdoor packaged unit
4 - 76 kW

pag. 170



MLI
High-efficiency full
inverter compact outdoor
packaged units
5 - 30 kW

pag. 182



DLI
Split units with EC
compressor
6 - 16 kW

pag. 188



MLP
High-efficiency full
inverter compact outdoor
packaged units
6 - 30 kW

pag. 194



PLP
Outdoor packaged
unit with R290
37 - 63 kW

pag. 202



PLI
High-efficiency full
inverter compact outdoor
packaged units
35 - 55 kW

pag. 208



PLE
Outdoor packaged unit
50 - 160 kW

pag. 214



PLN P
Outdoor packaged unit
50 - 180 kW

pag. 220



Evitech
Outdoor packaged unit
50 - 180 kW

pag. 230



LCX
Outdoor packaged unit
55 - 360 kW

pag. 238



VLS
Outdoor packaged unit
160 - 590 kW

pag. 254



GLE
Outdoor packaged unit
650 - 1130 kW

pag. 274



MTE
Outdoor motor-driven
condensing units
5 - 166 kW

pag. 282



LRE
Indoor and outdoor
motor-driven
evaporating units
40 - 680 kW

pag. 292

WW - Water chillers and heat pumps



MCW
Indoor packaged unit
5 - 39 kW

pag. 308



WRE
Indoor packaged unit
40 - 750 kW

pag. 314



WLE
Indoor and outdoor packaged unit
42 - 750 kW

pag. 330



MF - Total heat recovery multi-purpose units



MLE
Outdoor packaged air-water unit
40 - 240 kW

pag. 350



PLN P
Outdoor packaged air-water unit
50 - 150 kW

pag. 362



LEP
Indoor packaged water-water unit
50 - 470 kW

pag. 370

CT - Heat recovery and thermal ventilating unit

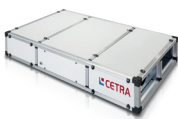

RPE
Mechanical ventilation units with heat recovery
500 - 6000 m³/h

pag. 388



FC - HYDRONIC INDOOR UNITS

Introduction	p.26	Cassette	
Fan coil		EFFETTO	p.80
ART-U	p.28	EFFETTO AirClissi	p.82
ART-U Canvas	p.34	ACQVARIA	p.84
ESTRO	p.38	ACQVARIA i	p.90
ESTRO i	p.50	Ducted unit	
FLAT S	p.56	FHP	p.96
FLAT S i	p.60	DMP	p.102
FLAT	p.64	DUCTIMAX	p.106
FLAT i	p.68	DUCTIMAX i	p.112
CFV	p.72	UTN	p.118
GHW	p.76	UTN i	p.126



Hydraulic indoor units



Vast range with over 1000 options!

It's 1961 and Galletti with its Jolly copper radiating plate enters the air conditioning world! More than half a century has gone by since then, there have been changes in the types of system and their intended use, markets and consumer demands grow and Galletti is still among the leaders in this sector.

The target is to come up with the most comprehensive range of solutions for indoor hydronic units with technologies and designs that, abreast with engineering evolution, have upgraded with the precise intention of combining reliability and innovation.

Today the offerings are completed with fan coil units with centrifugal or tangential fan, hybrid units specifically designed for residential applications, cassette units with axial-centrifugal fan, medium- and high-head ducted units and - in homage to tradition - convection heating models.

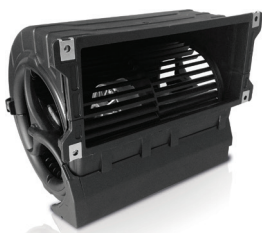

Energy savings with inverter-controlled EC motors

In the air conditioning sector there is by now a well-established trend toward the offering of solutions that combine performance and low energy consumption.

In line with its objective of continual innovation Galletti offers solutions with brushless motors which guarantee:

- » comfort of use thanks to the complete modulation of the air flow
- » about 50% operating costs saving compared to the conventional motors
- » the temperature setpoint in the air conditioned rooms is reached quickly
- » the power delivered is constantly adjusted according to the actual load conditions
- » exceptionally quiet operation at low speed, as in night-time mode



Quiet operation

The design of all the ventilation components of Galletti indoor units is developed exclusively by the company's engineering staff, backed by research and development facilities and over 50 years of specific know-how.

More specifically, the most recent studies on materials and aerodynamic profiles have led to the development of special fans and scrolls conceived to ensure performances in terms of quiet operation that are among the best in Europe and Eurovent certified, combined with a correct distribution of air, which assures maximum interior comfort in any operating mode.



Design and materials

On its hydronic indoor units Galletti uses cabinets with an exclusive design, ideal for both residential and commercial settings.

The quality of the materials used for their construction assures that they fully retain their characteristics over time.

The plastic parts are made of UV-stabilized ABS to maintain their colour intact over time.

The steel parts consist of 10/10 mm sheet with a double layer of paint, UV resistance class RUV 3 according to standard EN 10169-2.

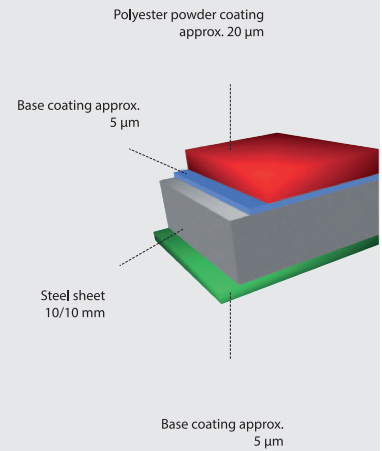

Efficient climate control

Galletti offers a wide range of on board or wall mounted controllers comprising more than 20 options according adjustment degree and comfort required.

Design and technology are combined in the latest-generation LED or LCD controllers: EVO, EVO-2-TOUCH e MYCOMFORT, which represent the state of the art in intelligent control of an indoor unit connected to a chiller or heat pump.

Management systems, master/slave options, auto adaptive adjustment of chiller/water pump, control of room humidity are only some of the salient features of qualified and reliable offerings.

Pressure-independent regulating valves (optional)

They can be combined with ON/OFF or MODULATING servomotors, guaranteeing a dynamic balancing of the system and preset regulation (thereby avoiding any calculation required by traditional balancing). They also offer a multitude of advantages, including:



- Efficient energy transfer and minimal pumping costs due to the absence of overflow in partial load conditions as a result of the precise pressure-independent flow control.
- Lower investment in the choice of pumps and reduced energy consumption since the required pressure head is lower than that of traditional configurations. Thanks to integrated piezometric connections, the solution to problems and the pumping optimization process can be achieved more quickly and easily.
- the costly commissioning of the system is no longer required to regulate the flow rate to the indoor units under rated conditions.
- The reduced movements of the modulating actuator, thanks to the integrated differential pressure regulator, guarantee a longer service life of the actuator itself and prevent the ambient temperature from being affected by the system's pressure fluctuations.
- The stability of the ambient temperature makes it possible to achieve a lower average temperature with the same level of comfort.
- Less complaints from system operators, because the flow rate, due to the correct functioning of the valve, never deviates from the design values.
- The installation of balancing valves in the distribution network is no longer required.

AVAILABLE FOR: ESTRO; ESTROI; DUCTIMAX; DUCTIMAXi; ACQVARIA; UTN; UTNi

Fan coil unit with Design cabinet, only 10 cm of minimum depth and EC motor

ART-U 1 - 4 kW



EC Motor



Tangential fan



2 pipes systems



Vertical installation

PLUS

- » A furnishing with an innovative design and width up to only 10 cm
- » Inverter-controlled EC motor
- » Low energy consumption

Design-driven innovation

From the extensive experience of Galletti in the development and design of fan coil units, and in confirmation of its continuous search for innovation, ART-U was created, a perfect combination of performance and design. ART-U is a unique product that, on the one hand is able to meet the increasingly stringent demands for energy efficiency, while on the other hand it reflects, for the first time, the latest trends in furnishings and interior design. With its width, which in some places is only 10 cm, and thanks to its unique lines, it was designed to be an absolutely all-purpose product that adapts perfectly to rigorous and essential environments as well as to warmer and more sophisticated spaces. The achievement of extremely high aesthetic standards has not weakened the usual construction integrity of Galletti products: striving for innovation has, in fact, also focused on the components and the use of new materials. With ART-U the state of the art has been redefined also in terms of technical performance, thanks to the use of computational fluid dynamics simulations for the optimisation of the heat exchange inside the indoor unit combined with the use of permanent magnet electric motors. It is the only innovative product that combines design, reduced width, and energy efficiency.

Design Contest

Its evolution has just begun but has already received important acknowledgment, winning over the judging panels of the most prestigious international industrial product design awards.



AVAILABLE VERSIONS

The versions of ART-U whose front panel has a metallic finish are summarised in the CMF table (Colours, Materials, Finishes). CMF is a true industrial design tool that focuses on the chromatic, tactile, and decorative identity of products and environments.

ART-U	Metallic Skin			
	Grey	White	Red	Black
Color	Silver	White RAL9010	Red RAL3020	Black RAL9005
Material			Aluminium	
Finish	Metallic brushed finish		Metallic matt finish	

MAIN COMPONENTS
Cabinet with a refined design

The elegant front panel consists of two sheets of aluminium with a polyethylene core and possibly a polyester-based surface coating. It is a light but very resistant material, created for covering façades in the building sector. The side panels are made of UV-stabilized ABS to maintain the colour over time. The polyethylene core acts as a flexible filler and thermal insulation while the aluminium provides structural strength and aesthetics.

Conveyors

Made of PVC. They are designed to optimise the air flow inside the hydronic indoor unit allowing optimal distribution of the air flow in the coil and low noise in every operating mode.

Upper grille

Consisting of adjustable fins made of anodised aluminium, compatible for on-board control installation. The ABS combs support the grilles and prevent them from being bent, thus always guaranteeing the user's safety.

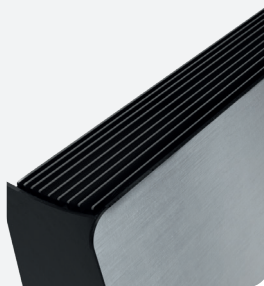
Front grille

Steel. Designed to stabilize the operation of the tangential fan.

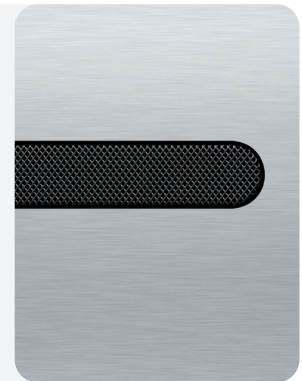
Electric motor

Permanent magnet EC motor with inverter integrated in the ventilation unit. An IP44, protection rating is guaranteed; therefore, dust inside is avoided and resistance to water spray is guaranteed.

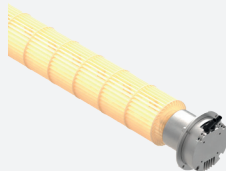
Tangential fans

Tangential fan, statically and dynamically balanced to reduce its noise during operation. The plastic material used for the blades guarantees, in comparison with metal fans, a reduction in vibrations and an absence of bending along the rotation axis. The blades are alternated with intermediate reinforcement disks in order to increase their sturdiness.

Heat exchangers

With a high efficiency turbocoil-type heat exchanger, and made with copper tubing and aluminium fins, it is equipped with brass manifolds and a vent valve. The hydrophilic treatment is applied to the fins as a standard treatment, to increase their efficiency during cooling and at the same time a greater resistance to aggressive atmospheres.

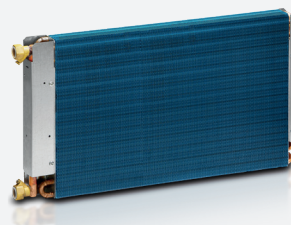
Air filter

Honey-comb polypropylene washable air filter, easily removable for maintenance operations.

Fan coil ART-U

AVAILABLE VERSIONS



ART-U Grey

The use of a natural brushed aluminium front panel combined with black side panels enhances the absolute elegance of this unique fan coil and its reduced width. This product, with its simple, clean, and essential lines, adapts perfectly to spaces where furnishings follow the latest trends and where a high level of design is required for each item.



ART-U White

The neutrality of the white ensures maximum integration with the space in an adaptive context, allowing the fan coil unit to almost disappear into the wall.

AVAILABLE VERSIONS**ART-U Red**

Thanks to the refined and elegant lines of this product, even a strong and decisive colour like red actually further enhances the unique personality of ART-U and turns it into a true furnishing classic.

**ART-U Black**

The unique black colour solution allows the fan coil to blend into the surrounding space, providing a touch of absolute elegance.

Fan coil ART-U

ACCESSORIES

EVO-2-TOUCH

The new EVO-2-TOUCH controller can also be installed directly on the unit and guarantees maximum temperature and humidity comfort combined with the ergonomics of its touch screen. The tap and swipe functions make the control experience similar to that of your smartphone.

The various screens are designed to make human-machine communication intuitive. Each page contains a few essential items of information that allow the consultation of the unit's main operating parameters and enable the initial control configuration according to system requirements.

The external frame of the interface is available in four different chrome plating options and is made with double aluminium foil and a polyethylene core.



DISC-COVER

The minimalist style of the DISC-COVER is in harmony with the elegant and essential lines of ART-U. Available in three different colours: white RAL9010, black RAL9005, and red RAL3020. It adapts perfectly to the style of the space to be air-conditioned, whether it be severe and formal or ironic. Its shape was purposely designed to make installation quick and easy even during cleaning and maintenance operations. The magnet coupling system allows its position to be adjusted according to the installation height and the position of the pipes.

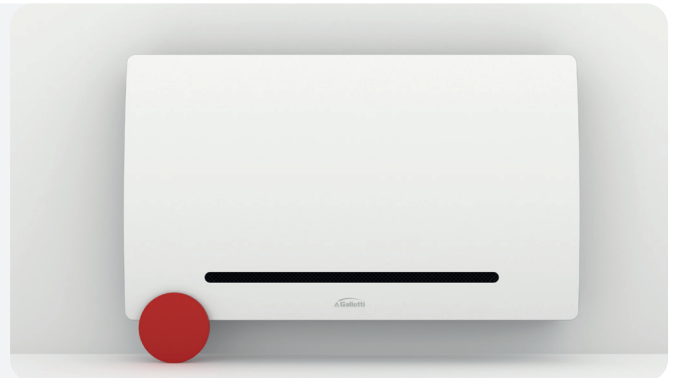

ACCESSORIES

Electronic microprocessor control panels with display

DIST	MYCOMFORT controller spacer for wall mounting
E2TK	Touch screen 2.8" user panel for EVO control EVO-2-TOUCH, frame in aluminium color black RAL9005
E2TY	Touch screen 2.8" user panel for EVO control EVO-2-TOUCH, frame in natural brushed aluminium
E2TW	Touch screen 2.8" user panel for EVO control EVO-2-TOUCH, frame in aluminium color white RAL9010
E2TR	Touch screen 2.8" user panel for EVO control EVO-2-TOUCH, frame in aluminium color red RAL 3020
EVOBOARD	EVO control circuit board ART-U
EVO DISP	User interface for ART-U EVO control with display
EYNAVEL	Device for Wi-Fi or Bluetooth communication between EVOBOARD and smartphone
KBEVS	EVO DISP on-board installation Kit for ART-U
MCLE	Microprocessor control with display MYCOMFORT LARGE
MCSUE	Humidity sensor for MYCOMFORT LARGE and EVO
MCSWE	Water sensor for MYCOMFORT and EVO controllers
TOUCHKB-W	Kit for installation of EVO-2-TOUCH onboard of ART-U version White

TOUCHKB-Y Kit for installation of EVO-2-TOUCH onboard of ART-U, Grey, Red e Black version

Electronic microprocessor control panels

TED SWA	Water temperature sensor for TED controls
TED10	Electronic controller for BLDC fan equipped with inverter and ON/OFF valves 230V
TEDKB-W	On-board ART-U White version installation kit suitable for TED controller
TEDKB-Y	Kit for installation of TED onboard of ART-U, Grey, Red and Black version

Auxiliary water drip trays, insulating shell, condensate drainage pump

GIVK-2	Insulating shell for KV - 2 ways valve
GIVK-3	Insulating shell for VKS - 3 ways valve

Base and enclosure elements

DISC-K	Covering foot for ART-U fan coil - black RAL 9005
DISC-R	Covering foot for ART-U fan coil - red RAL 3020
DISC-W	Covering foot for ART-U fan coil - white RAL 9010

Valves

V2VSTD	2-way valve, ON/OFF or MODULATING actuator, 230 V or 24 V power supply, hydraulic kit, for main heat exchanger
V3VSTD	2-way valves, ON/OFF or MODULATING actuator, 230 V or 24 V power supply, hydraulic kit, for main heat exchanger

RATED TECHNICAL DATA

ART-U			10				20				30			
Speed			1	2	3	4	1	2	3	4	1	2	3	4
Control voltage	(E)	V	2,00	5,50	7,00	10,0	2,00	5,50	7,00	10,0	2,00	5,50	7,00	10,0
Total cooling capacity	(1)(E)	kW	0,31	0,76	0,90	1,13	0,58	1,15	1,41	1,76	0,63	1,46	1,76	2,18
Sensible cooling capacity	(1)(E)	kW	0,21	0,63	0,73	0,91	0,42	0,89	1,08	1,36	0,45	1,18	1,44	1,78
FCEER class	(E)		C				C				B			
Water flow	(1)	l/h	53	132	156	198	100	198	242	303	108	253	305	379
Water pressure drop	(1)(E)	kPa	1	4	5	8	2	6	9	13	2	12	17	24
Heating capacity	(2)(E)	kW	0,29	0,82	1,05	1,40	0,53	1,09	1,31	1,62	0,63	1,54	1,87	2,30
FCCOP class	(E)		C											
Water flow	(2)	l/h	51	143	183	243	92	189	228	282	109	267	324	400
Water pressure drop	(2)(E)	kPa	1	4	6	11	2	7	10	14	2	12	17	24
Rated air flow		m ³ /h	40	148	207	312	82	224	287	389	91	302	374	461
Power input	(E)	W	4	7	9	14	4	10	12	17	5	11	15	24
Total sound power level	(3)(E)	dB(A)	28	41	46	54	28	41	47	54	28	42	47	54

ART-U			40				50			
Speed			1	2	3	4	1	2	3	4
Control voltage	(E)	V	2,00	5,50	7,00	10,0	2,00	5,50	7,00	10,0
Total cooling capacity	(1)(E)	kW	0,76	1,84	2,37	3,12	0,92	2,32	2,89	3,69
Sensible cooling capacity	(1)(E)	kW	0,53	1,38	1,77	2,33	0,65	1,72	2,15	2,77
FCEER class	(E)		B							
Water flow	(1)	l/h	131	315	406	535	157	398	496	634
Water pressure drop	(1)(E)	kPa	2	12	17	29	3	13	19	29
Heating capacity	(2)(E)	kW	0,74	1,99	2,49	3,21	0,95	2,56	3,16	4,02
FCCOP class	(E)		C				B			
Water flow	(2)	l/h	128	347	433	559	165	446	550	698
Water pressure drop	(2)(E)	kPa	2	11	17	26	2	13	19	28
Rated air flow		m ³ /h	104	363	496	724	129	439	587	831
Power input	(E)	W	5	12	17	27	5	12	18	30
Total sound power level	(3)(E)	dB(A)	31	42	47	54	32	42	47	54

(1) Water temperature 7°C/12°C, air temperature dry bulb 27°C, wet bulb 19°C (47% relative humidity) according to EN1397:2021

(2) Water temperature 45°C / 40°C, air temperature 20°C

(3) Sound power measured according to standards ISO 3741 and ISO 3742

(E) EUROVENT certified data

Power supply 230-1-50 (V-ph-Hz)

NOTE: The dimensional drawings of the ART-U units are the same of the ART-U Canvas. They are reported at page 37.

Fan coil unit with Design cabinet, only 10 cm of minimum depth and EC motor

ART-U Canvas 1 - 4 kW

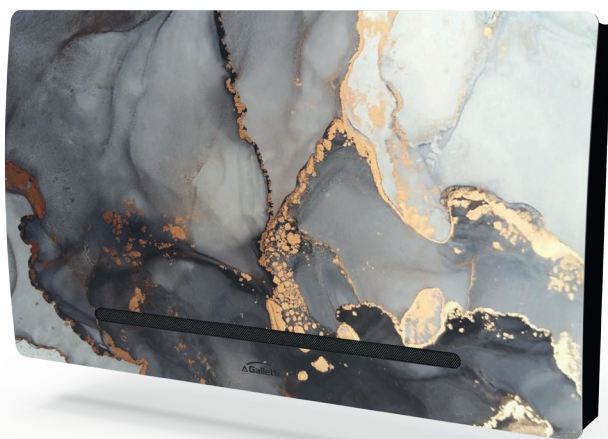

Now it's up to you

Thanks to ART-U Canvas, a new level in indoor air conditioning is being achieved. A product that was already a unique offering in its field is now being further enhanced: ART-U is a versatile platform thanks to the complete customisation of the front panel. The fan coil panel becomes a veritable painter's canvas, ready to be customized by the interior architect. On ART-U Canvas any solid colour, image, or high quality photograph can be reproduced. No minimum quantities are required for the customization of the fan coil, to ensure maximum freedom for the interior architect, whatever the size of the project.

With ART-U Canvas there are no limits to creativity; now it's up to you to choose the perfect version to blend in stylistically with the space to be air-conditioned.



EC Motor



Tangential fan



2 pipes systems



Vertical installation

PLUS

- » A furnishing with an innovative design and width up to only 10 cm
- » Inverter-controlled EC motor
- » Low energy consumption
- » Complete customization of the front panel

AVAILABLE VERSIONS

Canvas is available in two versions: Total Graphic Skin and Graphic Skin.

Total Graphic Skin allows for the customisation of the entire surface of the front panel with the reproduction of graphics, photographs and plain color.

The Graphic Skin version makes it possible to reproduce images while leaving the natural brushed aluminium or RAL9010 white panel partially visible.

These two versions of ART-U Canvas are summarized according to the CMF table (Colours, Materials, Finishes). CMF is a true industrial design tool that focuses on the chromatic, tactile, and decorative identity of products and environments.

AVAILABLE VERSIONS

Total Graphic Skin

Graphic Skin

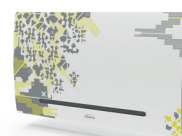

Colour	Customised
Material	Aluminium
Finishing	Matt
	Matt graphics and brushed metallic background
	Matt graphics and matt RAL9010 white metallic background

ART-U CANVAS



ART-U becomes a platform that can be customised according to the suggestions of the interior architect. The front panel colour can be selected from over 3000 colour variations offered by the RAL and PANTONE colour charts.



Any geometric texture or material effect can create a unique design that expresses your personality in every detail.



With ART-U Canvas there are no limits to creativity. The possibility of customising the panel with images and photographs makes this fan coil a true furnishing accessory.

Fan coil - ART-U Canvas

Fan coil ART-U Canvas



With ART-U Canvas, innovation goes hand in hand with imagination. This smart, high-performance fan coil was created to rewrite the rules of design and inspire customisations that go far beyond the surface of the fan coil.

ART-U CREATOR ONLINE CONFIGURATOR

ART-U

ART-U CANVAS

1 ART-U MODEL 2 IMAGE 3 FINISH 4 COLOUR 5 LOGO 6 OTHER FINISHES 7 ACCESSORIES

ART-U MODEL 10 20 30 40 50

SAVE

UNDO REDO CLEAR ALL

Using the online ART-U Creator software you can give shape to your air conditioning design idea. This tool allows you to quickly configure your ART-U Canvas, choosing the graphics for the front panel and the colour of the other product components. There is a product for every solution: configuring the style of your interiors has never been so easy.

Contact us at productsupport@galletti.it to request access to the first aesthetic configurator dedicated to fan coils.

DIMENSIONAL DRAWINGS

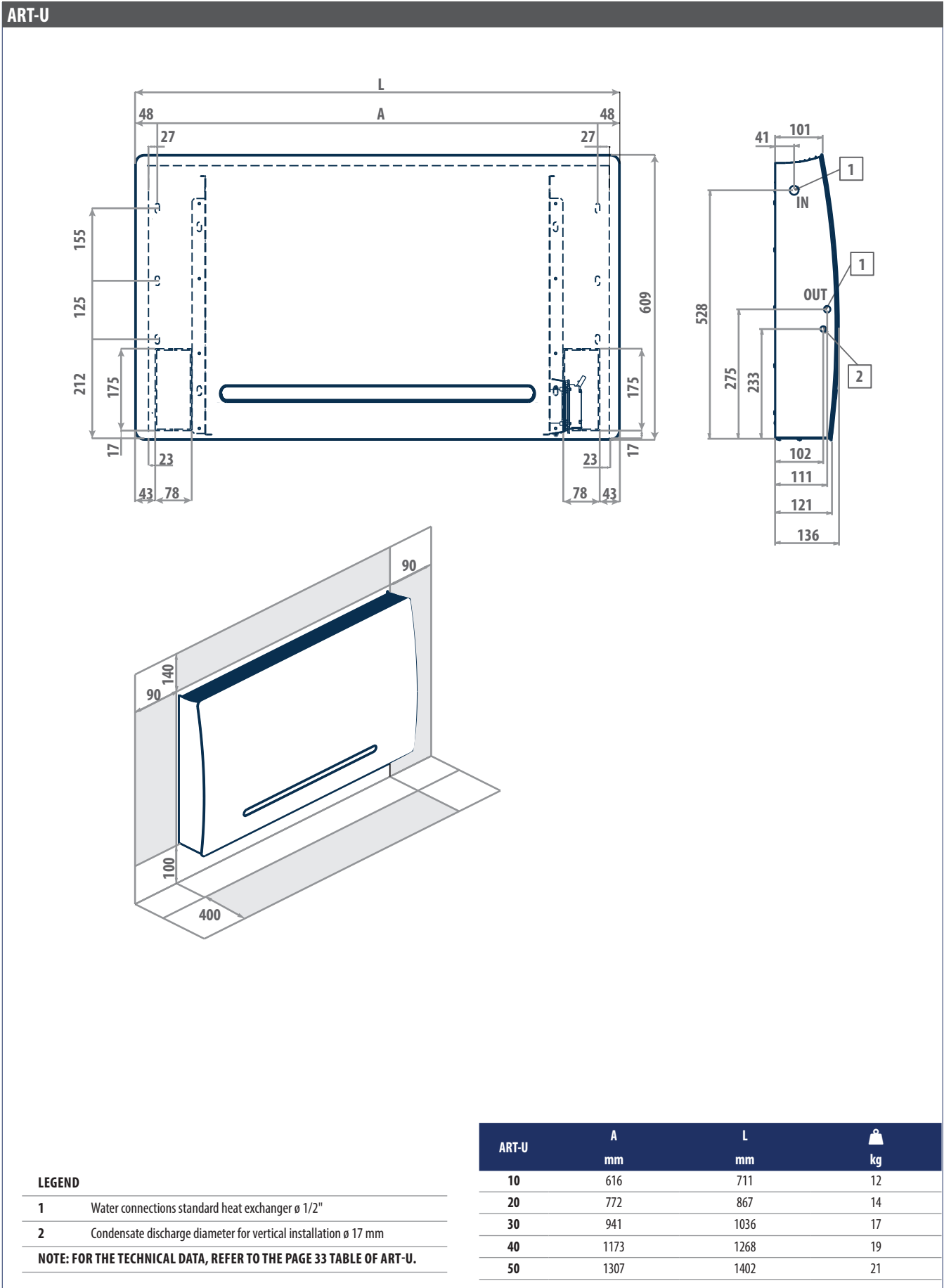

Fan coil units with centrifugal fan

ESTRO 1 - 11 kW



The most complete range of fan coil units on the market featuring the Galletti technology, quality level and reliability.

The ESTRO series is undoubtedly the line of fan coil units with the most complete range of models and accessories that are able to meet the needs of professionals in the field.

The range consists of 20 models in 4 versions.

For the ESTRO project we selected top quality materials which, together with the great care and attention dedicated to the assembly of the main constructive components, make the ESTRO fan coil units highly reliable from a performance standpoint while minimising noise levels.

The conception underlying the ESTRO series construction makes it possible to combine models for vertical and horizontal installation: models for surface mounting on walls, floors/ceilings and recess mounting in walls/ceilings plus low body model for floor installation.

In its recess-mounted ductable version, ESTRO has a number of accessories that permit quick and economical installation with flexible ducts directly coupled with air diffusion grilles.

ESTRO can be combined with a range of on-board or wall-mounted control panels consisting of 20 options, depending on the level of comfort and adjustment required.

PLUS

- » 3 speed motor
- » ABS centrifugal fans
- » Heat exchanger up to 4 rows
- » Reversible water connections
- » Steel cabinet / ABS



AVAILABLE VERSIONS



ESTRO FL

Version with cabinet, suitable for wall mounting. Vertical air flow, filter on the air intake securely attached to the cabinet with quarter-turn screws.

ESTRO FL is available in 20 models.



ESTRO FA

Wall mounted with cabinet. The inclined front air flow makes the ESTRO FA version especially suited for installation in recesses up to a depth of 150 mm.

ESTRO FA is available in 19 models.



ESTRO FU

Version with cabinet, suitable for floor and ceiling mounting. The cabinet has air outlet grilles and air intake grilles with built-in filter.

ESTRO FU is available in 20 models.

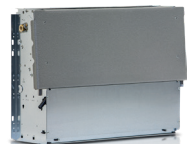

ESTRO FC

Model for vertical and horizontal recess mounting, air intake in line with the outlet, thermally insulated galvanised sheet steel body. Plenum and connectors complete the air intake and the air flow into the room.

ESTRO FC is available in 20 models.

Hydraulic indoor units ESTRO

MAIN COMPONENTS

Cabinet

Composed of a painted steel sheet panel, side panels, air outlet grille (swinging by 180°) and back suction grille built from ABS.

Round shapes and colours that can satisfy all interior decorating needs, in line with architectural requirements.



Structure

Built from galvanised steel sheet of extra thickness, heat and sound insulated by means of Class 1 self-extinguishing panels. FU and FC versions have a double drip tray for collecting condensate.

Heat exchanger

High efficiency heat exchanger made with copper piping and aluminium fins, provided with brass manifolds and vent valve. The water connections are reversible at the time of installation. On request it is possible to mount an additional heat exchanger for 4-pipe systems.

Electric motor

It is mounted on vibration dampers, with permanently activated capacitor and thermal protection of the windings, and is directly coupled with the fans. It is available with 3 rotation speeds to meet all specific requirements in terms of performance, noise levels, and power consumption.

Fans

Double suction centrifugal fans, statically and dynamically balanced, manufactured from anti-static ABS, with blades having an airfoil section and offset modules. The fans are housed in a low-noise ABS volute with high-efficiency profile.

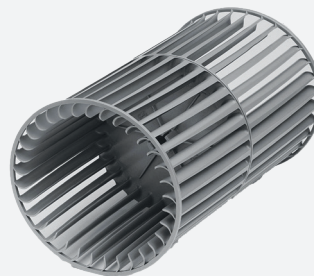

Air filter

Honey-comb polypropylene washable air filter, easily removable for maintenance operations. On FU version the air filters are fitted onto the airinlet grille.

CONFIGURATOR

The models are completely configurable by selecting the version and the options. To the right is shown an example of configuration.

Version	Field	1	2	3	4	5	6	7	8	9	10	11
EF03		L	0	M	0	1	E	0	0	0	0	A

EF Product type ESTRO; 03 Size

To verify the compatibility of the options, use the selection software or the price list.

CONFIGURATOR

1 Version

- A A - Wall mounted with cabinet
- C C - Recessed installation
- L L - Wall mounted with cabinet
- P P - Ceiling installation with cabinet

2 Motor

- 0 3-speed motor
- I BLDC motor

3 Main coil hydraulic side

- L Water connections on the left side
- M Water connections on the left side - 4 rows
- R Water connections on the right
- S Water connections on the right side - 4 rows

4 Additional coil hydraulic side / heating element

- 0 Absent
- E RE - Electrical heating elements
- L Water connections on the left side
- R Water connections on the right

5 Valve

- 0 Absent
- 1 VKS - 3 ways valve - 230 V - ON/OFF - complete hydraulic kit
- 2 KV - 2 ways valve - 230 V - ON/OFF
- 3 VKMS - 3 ways valve - 24 V - MODULATING - complete hydraulic kit
- 4 KVM - 2 ways valve - 24 V - MODULATING
- 5 VKS24 - 3 way valve - 24 V - ON/OFF - complete hydraulic kit
- 6 KV24 - 2 way valve - 24 V - ON/OFF
- A VKSND - 3 way valve - 230 V - ON/OFF - hydraulic kit on coil side
- B VKMSND - 3 ways valve - 24 V - MODULATING - hydraulic kit on coil side
- C VKS24ND - 3 ways valve - 24 V - ON/OFF - hydraulic kit on coil side
- H VPIK - 2-way valve - pressure independent - 230 V - ON/OFF
- I VPIKM - 2-way valve - pressure independent - 24 V - MODULATING

6 Control panel

- 0 Absent

1 CB - On-board speed selector

- 3 TIB - Speed selector, thermostat and S/W selecting switch
- 4 TED 2T - microprocessor control for 2 pipes
- 5 TED 4T - microprocessor control for 4 pipes
- 6 TED 10 - microprocessor control for BLDC
- A MCBE - MYCOMFORT BASE
- C MCLE - MYCOMFORT LARGE
- E EVOBOARD - Circuit board
- F EVO BOARD+EVO DISP - (Circuit board + Wall-mounted display)
- G EVOBOARD circuit board + NAVEL Wi-Fi module

7 Probes

- 0 Absent
- 1 SA - Remote air probe for MYCOMFORT and EVO
- 2 SW - Water probe for MYCOMFORT and EVO
- 3 SU - Humidity probe for MYCOMFORT and EVO
- 4 SA+SW - Remote air and water probes for MYCOMFORT and EVO
- 5 SA+SU - Remote air and humidity probes for MYCOMFORT and EVO
- 6 SA+SU+SW - Remote air, water, humidity probes for MYCOMFORT and EVO
- A TC - Thermostat for minimum water temperature
- B SA - Remote air probe for TED
- C SW - Water probe for TED
- D SA + SW - Air and water probes for TED

8 Accessories

- 0 Absent
- 4 BV - Auxiliary drip tray
- 5 BH - Auxiliary drip tray
- 6 GIVK - Insulating shell

9 Filter

- 0 Standard filter air

10 Release

- 0 0
- A A

CONTROL PANELS

Electromechanical control panels

CB	On-board speed switch
TC	Thermostat for minimum water temperature in heating mode (42 °C)

Electronic microprocessor control panels with display

DIST	MYCOMFORT controller spacer for wall mounting
E2TK	Touch screen 2.8" user panel for EVO control EVO-2-TOUCH, frame in aluminium color black RAL9005
E2TY	Touch screen 2.8" user panel for EVO control EVO-2-TOUCH, frame in natural brushed aluminium
EVOBOARD	Circuit board for EVO control
EVODISP	User interface with display for EVO controller
EYNAVEL	Device for Wi-Fi or Bluetooth communication between EVOBOARD and smartphone

KBESTE	MYCOMFORT on-board installation kit for ESTRO
MCBE	MYCOMFORT BASE electronic controller with display
MCLE	Microprocessor control with display MYCOMFORT LARGE
MCSUE	Humidity sensor for MYCOMFORT LARGE and EVO
MCSWE	Water sensor for MYCOMFORT and EVO controllers

Electronic microprocessor control panels

KB A	On-board ESTRO FA installation kit suitable for TED controller
KB L DX	On-board ESTRO FL/FU/FB installation kit on the right side suitable for TED controller
KB L SX	On-board ESTRO FL/FU/FB installation kit on the left side suitable for TED controller
TED 2T	Electronic controller for AC fan control and one ON/OFF 230 V valve
TED 4T	Electronic controller for AC fan control and two ON/OFF 230 V valves
TED SWA	Water temperature sensor for TED controls

ACCESSORIES

Power interface and regulating louver controllers

CSB	On-board controller for opening and closing the motor-driven regulating louver
CSD	Recess mounted controller for opening and closing the SM motor-driven regulating louver
KP	Power interface for connecting in parallel up to 4 fan coil units to the one controller

Additional heat exchanger for 4-pipe systems

DF	1-row additional heat exchanger for 4-pipe systems (not suitable for ESTRO "M" models)
-----------	--

Auxiliary water drip trays, insulating shell, condensate drainage pump

BH	Auxiliary water drip tray for horizontal installation fan coil units
BV	Auxiliary water drip tray for vertical installation fan coil units
GIVKL	Insulating shell for VKS valve, water connections on the left
GIVKR	Insulating shell for VKS valve, water connections on the right
KSC	Condensate drainage pump kit

Base and enclosure elements

D	Support elements for ESTRO FC
ZA	Pair of support covering elements with front grille for ESTRO FA
ZAG	Pair of support covering elements for ESTRO FA
ZL	Pair of support covering elements for ESTRO FL
ZLG	Pair of support covering elements with front grille for ESTRO FL

Rear covering panels

PH	Rear painted panel for horizontal installation with cabinet
PV	Rear painted panel for vertical installation with cabinet

Electrical heating elements

RE	Heating element with installation kit, relay box and safety devices
-----------	---

Air inlet and outlet grilles

GE	Aluminium external air intake grille with subframe
GEF	Aluminium external air intake grille with subframe and air filter
GM	Aluminium air outlet grille with 2-row fins and subframe
RGC	Plenum with circular collars for air outlet grille

Plenum and connectors

RA90	Angular inlet connector
RAD	Straight inlet connector
RADC	Air inlet plenum with circular collars
RM90	Angular outlet connector
RM90C	Angular outlet insulated connector
RMCD	Straight outlet insulated connector
RMCD C	Air outlet plenum with circular collars
RMD	Straight outlet connector

External air intake louvers

S	Manual external air intake louver
----------	-----------------------------------

SM	Motor-driven louver, with motor on the right with transformer
SM	Motor-driven louver, with motor on the left with transformer
SMC	Motor driven louver, with motor on the right, with transformer
SMC	Motor driven louver, with motor on the left, with transformer

Valves

KV	2-way valve, ON/OFF actuator, hydraulic kit on water connection side for main heat exchanger
KV24	2-way valve, ON/OFF actuator, 24 V power supply, hydraulic kit on water connection side for main heat exchanger
KV24DF	2-way valve, ON/OFF actuator, 24 V power supply, hydraulic kit on water connection side for main and additional heat exchanger
KVDF	2-way valve, ON/OFF actuator, 230 V power supply, hydraulic kit on water connection side for main and additional heat exchanger
KVM	2-way valve, MODULATING actuator, 24 V power supply, hydraulic kit on water connection side for main heat exchanger
KVMDF	2-way valve, MODULATING actuator, 24 V power supply, hydraulic kit on water connection side for main and additional heat exchanger
VKDF	3-way valve, ON/OFF actuator, 230 V power supply, complete hydraulic kit for additional heat exchanger
VKDF24	3-way valve, ON/OFF actuator, 24 V power supply, complete hydraulic kit for additional heat exchanger
VKDF24ND	3-way valve, ON/OFF actuator, 24 V power supply, hydraulic kit without holder, for additional heat exchanger
VKDFND	3-way valve, ON/OFF actuator, 230 V power supply, hydraulic kit without holder, for additional heat exchanger
VKMDF	3-way valve, MODULATING actuator, 24 V power supply, complete hydraulic kit for additional heat exchanger
VKMDFND	3-way valve, MODULATING actuator, 24 V power supply, hydraulic kit without holder, for additional heat exchanger
VKMS	3-way valve, MODULATING actuator, 24 V power supply, complete hydraulic kit for main heat exchanger
VKMSND	3-way valve, MODULATING actuator, 24 V power supply, hydraulic kit without holder, for main heat exchanger
VKS	3-way valve, ON/OFF actuator, 1230 V power supply, complete hydraulic kit for main heat exchanger
VKS24	3-way valve, ON/OFF actuator, 24 V power supply, complete hydraulic kit for main heat exchanger
VKS24ND	3-way valve, ON/OFF actuator, 24 V power supply, hydraulic kit without holder, for main heat exchanger
VKSND	3-way valve, ON/OFF actuator, 230 V power supply, hydraulic kit without holder, for main heat exchanger
VPIC	2-way valves pressure independent, ON/OFF or MODULATING actuator, 230 V or 24 V power supply, hydraulic kit, for main heat exchanger

Hydraulic indoor units ESTRO

2 PIPES - RATED TECHNICAL DATA

ESTRO			1			2			3			4		
Speed			min	med	max	min	med	max	min	med	max	min	med	max
Total cooling capacity	(1)(E)	kW	0,75	0,90	1,12	1,02	1,21	1,50	1,24	1,48	1,69	1,34	1,66	1,91
Sensible cooling capacity	(1)(E)	kW	0,57	0,68	0,84	0,77	0,94	1,16	0,93	1,10	1,25	0,98	1,20	1,37
FCEER class	(E)		E											
Water flow	(2)	l/h	129	155	193	176	208	258	214	255	291	231	286	329
Water pressure drop	(2)(E)	kPa	4	5	7	7	9	13	8	11	14	7	10	13
Heating capacity	(3)(E)	kW	0,95	1,11	1,32	1,21	1,48	1,82	1,45	1,72	1,84	1,50	1,81	2,15
FCCOP class	(E)		E											
Water flow	(3)	l/h	164	191	227	208	255	313	250	296	317	258	312	370
Water pressure drop	(3)(E)	kPa	5	6	8	8	11	15	9	12	14	6	9	12
Rated air flow		m ³ /h	127	189	231	167	233	319	210	271	344	214	271	344
Power input	(E)	W	18	21	32	21	28	37	25	36	53	24	36	53
Total sound power level	(4)(E)	dB(A)	30	32	40	37	42	47	38	44	49	40	44	50

ESTRO			4M			5			6			6M		
Speed			min	med	max	min	med	max	min	med	max	min	med	max
Total cooling capacity	(1)(E)	kW	1,48	1,81	2,19	1,57	1,99	2,36	1,73	2,34	2,87	1,90	2,60	3,23
Sensible cooling capacity	(1)(E)	kW	1,04	1,28	1,55	1,15	1,53	1,82	1,23	1,66	2,05	1,30	1,79	2,24
FCEER class	(E)		D			E			D			D		
Water flow	(2)	l/h	255	312	377	270	343	406	298	403	494	327	448	556
Water pressure drop	(2)(E)	kPa	10	14	20	8	12	16	6	9	13	7	12	17
Heating capacity	(3)(E)	kW	1,53	1,88	2,29	1,74	2,26	2,70	1,76	2,37	2,94	1,94	2,68	3,37
FCCOP class	(E)		E											
Water flow	(3)	l/h	263	324	394	300	389	465	303	408	506	334	461	580
Water pressure drop	(3)(E)	kPa	9	12	17	8	12	17	5	8	11	6	10	15
Rated air flow		m ³ /h	211	271	344	267	341	442	293	341	442	241	341	442
Power input	(E)	W	30	45	66	29	44	57	29	43	56	29	43	56
Total sound power level	(4)(E)	dB(A)	41	45	51	35	43	48	36	42	48	35	43	49

ESTRO			7			7M			8			8M		
Speed			min	med	max	min	med	max	min	med	max	min	med	max
Total cooling capacity	(1)(E)	kW	1,94	2,58	3,45	2,44	3,33	4,48	2,47	3,21	4,23	2,48	3,29	4,40
Sensible cooling capacity	(1)(E)	kW	1,41	1,99	2,69	1,69	2,31	3,12	1,76	2,39	3,05	1,90	2,53	3,40
FCEER class	(E)		E			D			D			D		
Water flow	(2)	l/h	334	444	594	420	573	771	425	553	728	472	627	837
Water pressure drop	(2)(E)	kPa	4	7	12	6	11	18	5	8	12	7	12	20
Heating capacity	(3)(E)	kW	2,39	3,13	4,05	2,51	3,40	4,57	2,47	3,24	4,24	2,43	3,21	4,30
FCCOP class	(E)		E											
Water flow	(3)	l/h	412	539	697	432	585	787	425	558	730	482	637	852
Water pressure drop	(3)(E)	kPa	5	8	13	5	9	15	4	6	10	6	10	17
Rated air flow		m ³ /h	331	450	640	320	450	640	420	497	706	361	497	706
Power input	(E)	W	40	50	65	37	61	98	38	61	98	38	61	98
Total sound power level	(4)(E)	dB(A)	35	43	52	36	44	53	35	43	53	39	47	54

(1) Water temperature 7°C / 12°C, air temperature dry bulb 27°C, wet bulb 19°C (47% relative humidity) according to EN1397:2021

(2) Water temperature 7°C / 12°C, air temperature dry bulb 27°C, wet bulb 19°C (47% relative humidity)

(3) Water temperature 45°C / 40°C, air temperature 20°C

(4) Sound power measured according to standards ISO 3741 and ISO 3742

(E) EUROVENT certified data

Power supply 230-1-50 (V-ph-Hz)

2 PIPES - RATED TECHNICAL DATA

ESTRO			9			9M			95			10		
Speed			min	med	max	min	med	max	min	med	max	min	med	max
Total cooling capacity	(1)(E)	kW	2,95	3,59	4,41	3,47	4,30	5,30	3,37	4,12	5,15	3,88	5,14	6,53
Sensible cooling capacity	(1)(E)	kW	2,27	2,85	3,55	2,42	3,00	3,72	2,29	2,93	3,72	2,75	3,70	4,73
FCEER class	(E)		D			D			D			E		
Water flow	(2)	l/h	508	618	759	598	740	913	580	709	887	668	885	1124
Water pressure drop	(2)(E)	kPa	7	10	14	11	16	24	10	14	21	5	9	12
Heating capacity	(3)(E)	kW	3,31	4,08	4,98	3,53	4,37	5,39	3,52	4,32	5,49	3,97	5,17	6,49
FCCOP class	(E)		E											
Water flow	(3)	l/h	570	703	858	608	753	928	606	744	945	684	890	1118
Water pressure drop	(3)(E)	kPa	7	10	14	10	14	20	8	12	18	4	7	10
Rated air flow		m ³ /h	527	605	785	470	605	785	601	615	814	661	771	1011
Power input	(E)	W	47	68	98	47	68	98	52	73	107	86	127	182
Total sound power level	(4)(E)	dB(A)	43	49	56	44	50	57	44	51	58	47	54	61

ESTRO			10M			11			11M			12		
Speed			min	med	max	min	med	max	min	med	max	min	med	max
Total cooling capacity	(1)(E)	kW	4,32	5,69	7,20	4,00	6,07	7,78	4,55	6,81	8,74	6,76	8,53	10,7
Sensible cooling capacity	(1)(E)	kW	2,98	3,93	4,99	2,94	4,46	5,72	3,18	4,78	6,15	4,91	6,22	7,76
FCEER class	(E)		E											
Water flow	(2)	l/h	744	980	1240	689	1045	1340	784	1173	1505	1164	1469	1841
Water pressure drop	(2)(E)	kPa	8	14	21	6	13	20	9	19	29	14	22	32
Heating capacity	(3)(E)	kW	4,28	5,56	6,96	4,39	6,53	8,37	4,75	7,02	9,00	7,45	9,29	12,2
FCCOP class	(E)		E											
Water flow	(3)	l/h	737	957	1199	756	1124	1441	818	1209	1550	1283	1600	2101
Water pressure drop	(3)(E)	kPa	7	11	16	6	12	18	8	16	25	14	20	33
Rated air flow		m ³ /h	570	771	1011	682	1022	1393	642	1022	1393	1154	1317	1850
Power input	(E)	W	86	127	182	109	169	244	109	169	244	210	240	310
Total sound power level	(4)(E)	dB(A)	48	55	62	49	60	67	50	61	68	60	64	71

- (1) Water temperature 7°C / 12°C, air temperature dry bulb 27°C, wet bulb 19°C (47% relative humidity) according to EN1397:2021
 (2) Water temperature 7°C / 12°C, air temperature dry bulb 27°C, wet bulb 19°C (47% relative humidity)
 (3) Water temperature 45°C / 40°C, air temperature 20°C
 (4) Sound power measured according to standards ISO 3741 and ISO 3742
 (E) EUROVENT certified data
 Power supply 230-1-50 (V-ph-Hz)

Hydraulic indoor units ESTRO

4 PIPES - RATED TECHNICAL DATA

ESTRO			1			2			3			4		
Speed			min	med	max	min	med	max	min	med	max	min	med	max
Total cooling capacity	(1)(E)	kW	0,74	0,88	1,10	0,97	1,11	1,42	1,22	1,44	1,64	1,24	1,52	1,74
Sensible cooling capacity	(1)(E)	kW	0,56	0,67	0,83	0,73	0,87	1,10	0,91	1,07	1,22	0,96	1,18	1,41
FCEER class	(E)		E											
Water flow	(2)	l/h	127	152	189	167	191	245	210	248	282	214	262	300
Water pressure drop	(2)(E)	kPa	4	5	7	6	8	12	8	11	14	7	10	13
Heating capacity	(3)(E)	kW	1,18	1,31	1,49	1,31	1,49	1,66	1,36	1,56	1,76	1,36	1,56	1,76
FCCOP class	(E)		E											
Water flow	(3)	l/h	102	113	128	113	128	143	117	134	152	117	134	152
Water pressure drop	(3)(E)	kPa	2	3	4	3	4	4	4	5	7	4	5	6
Rated air flow		m ³ /h	146	184	226	174	225	307	205	261	330	205	261	327
Power input	(E)	W	18	21	32	21	28	37	25	36	53	24	36	53
Total sound power level	(4)(E)	dB(A)	30	32	40	33	39	45	40	44	49	38	44	50

ESTRO			5			6			7		
Speed			min	med	max	min	med	max	min	med	max
Total cooling capacity	(1)(E)	kW	1,55	1,96	2,32	1,70	2,29	2,81	1,92	2,54	3,36
Sensible cooling capacity	(1)(E)	kW	1,14	1,50	1,79	1,21	1,62	2,01	1,40	1,96	2,61
FCEER class	(E)		E			D			E		
Water flow	(2)	l/h	267	338	400	293	394	484	331	437	579
Water pressure drop	(2)(E)	kPa	8	12	16	5	8	11	4	7	12
Heating capacity	(3)(E)	kW	1,78	2,18	2,53	1,88	2,31	2,68	2,82	3,47	4,20
FCCOP class	(E)		E								
Water flow	(3)	l/h	153	188	218	162	199	231	243	299	362
Water pressure drop	(3)(E)	kPa	2	3	3	2	3	4	8	12	16
Rated air flow		m ³ /h	238	334	432	237	332	431	316	444	628
Power input	(E)	W	29	44	57	29	43	56	37	61	98
Total sound power level	(4)(E)	dB(A)	34	43	48	33	41	47	36	45	53

ESTRO			8			9			95		
Speed			min	med	max	min	med	max	min	med	max
Total cooling capacity	(1)(E)	kW	2,44	3,17	4,16	3,06	3,74	4,57	3,49	4,27	5,31
Sensible cooling capacity	(1)(E)	kW	1,74	2,36	2,99	2,23	2,80	3,47	2,38	3,01	3,78
FCEER class	(E)		D								
Water flow	(2)	l/h	420	546	716	527	644	787	601	735	914
Water pressure drop	(2)(E)	kPa	5	7	12	7	10	14	10	14	20
FCCOP class	(E)		E								
Heating capacity	(3)(E)	kW	2,73	3,22	3,82	3,55	4,07	4,64	3,70	4,20	4,84
Water flow	(3)	l/h	235	277	329	306	350	400	319	362	417
Water pressure drop	(3)(E)	kPa	8	10	14	5	6	8	7	9	12
Rated air flow		m ³ /h	356	490	690	460	593	763	478	603	792
Power input	(E)	W	38	61	98	47	68	98	52	73	107
Total sound power level	(4)(E)	dB(A)	39	46	56	48	53	58	46	52	59

(1) Water temperature 7°C / 12°C, air temperature dry bulb 27°C, wet bulb 19°C (47% relative humidity) according to EN1397:2021

(2) Water temperature 7°C / 12°C, air temperature dry bulb 27°C, wet bulb 19°C (47% relative humidity)

(3) Water temperature 65°C / 55°C, air temperature 20°C

(4) Sound power measured according to standards ISO 3741 and ISO 3742

(E) EUROVENT certified data

4 PIPES - RATED TECHNICAL DATA

ESTRO			10			11			12		
Speed			min	med	max	min	med	max	min	med	max
Total cooling capacity	(1)(E)	kW	3,84	5,10	6,46	3,96	5,99	7,64	6,70	8,44	10,5
Sensible cooling capacity	(1)(E)	kW	2,73	3,67	4,67	2,91	4,40	5,61	4,86	6,15	7,63
FCEER class	(E)		E								
Water flow	(2)	l/h	661	878	1112	682	1031	1316	1154	1453	1806
Water pressure drop	(2)(E)	kPa	5	8	12	5	10	16	14	21	30
FCCOP class	(E)		E								
Heating capacity	(3)(E)	kW	5,02	6,02	6,97	4,85	6,29	7,35	6,93	8,01	9,52
Water flow	(3)	l/h	432	518	600	418	542	633	597	690	820
Water pressure drop	(3)(E)	kPa	14	19	24	14	22	29	24	31	42
Rated air flow		m ³ /h	565	765	998	636	1007	1362	999	1300	1814
Power input	(E)	W	86	127	182	109	169	244	210	240	310
Total sound power level	(4)(E)	dB(A)	46	54	60	48	58	66	63	64	71

(1) Water temperature 7°C / 12°C, air temperature dry bulb 27°C, wet bulb 19°C (47% relative humidity) according to EN1397:2021

(2) Water temperature 7°C / 12°C, air temperature dry bulb 27°C, wet bulb 19°C (47% relative humidity)

(3) Water temperature 65°C / 55°C, air temperature 20°C

(4) Sound power measured according to standards ISO 3741 and ISO 3742

(E) EUROVENT certified data

DIMENSIONAL DRAWINGS

ESTRO FL

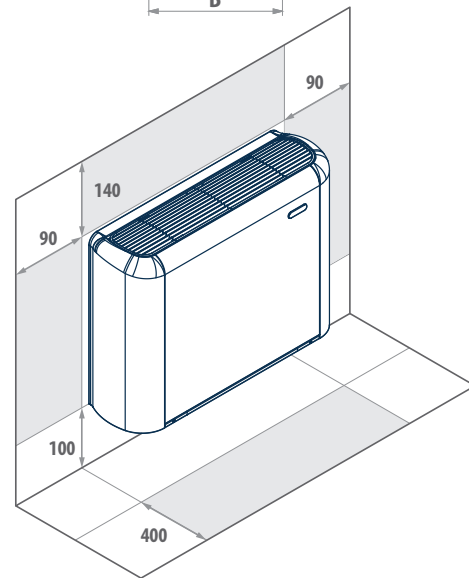
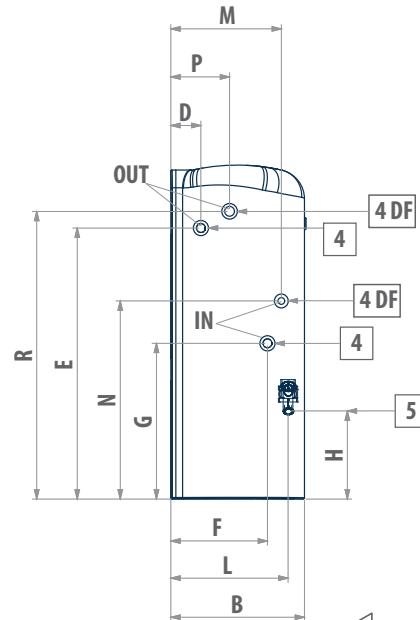
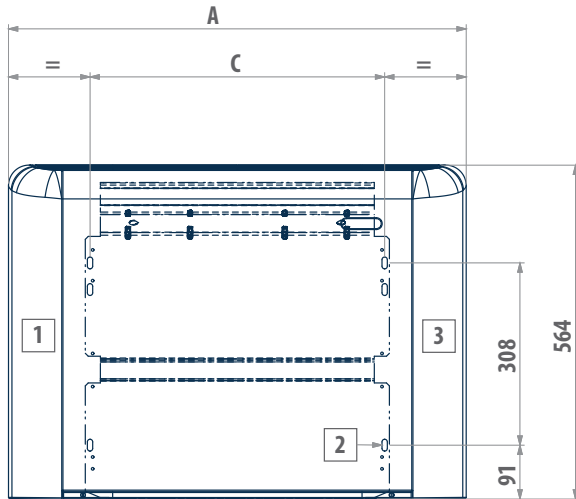

LEGEND

1	Usable space for plumbing connections
2	Slots for installation on the wall
3	Usable space for electrical connections
4	Standard heat exchanger water connections
4DF	DF 1-row additional heat exchanger water connections
5	Condensate drainage

ESTRO	1	2	3	4	4M	5	6	6M	7	7M	8	8M	9	9M	95	10	10M	11	11M	12	
ON/OFF motor (3 speed)	x	x	x	x	x	x	x	x	x	x	x	x	x	x	x	x	x	x	x	x	x
Inverter-controlled motor	x	-	x	x	x	x	x	x	x	-	x	-	x	x	x	-	-	x	x	-	-

x = available

ESTRO	A	B	C	D	E	F	G	H	L	M	N	P	R	4	4DF	5	kg
	mm	mm	mm	mm	mm	mm	mm	mm	mm	mm	mm	mm	mm	"	"	mm	kg
1 - 2 - 3 - 4 - 4M	774	226	498	51	458	163	263	149	198	187	335	99	486	1/2	1/2	16	21
5 - 6 - 6M	984	226	708	51	458	163	263	149	198	187	335	99	486	1/2	1/2	16	27
7 - 7M - 8 - 8M - 9 - 9M	1194	226	918	51	458	163	263	149	198	187	335	99	486	1/2	1/2	16	33
95	1194	251	918	48	497	185	259	155	220	195	348	120	478	3/4	1/2	16	34
10 - 10M - 11 - 11M	1404	251	1128	48	497	185	259	155	220	195	348	120	478	3/4	1/2	16	43
12	1614	251	1338	48	497	185	259	155	220	195	348	120	478	3/4	1/2	16	53

DIMENSIONAL DRAWINGS

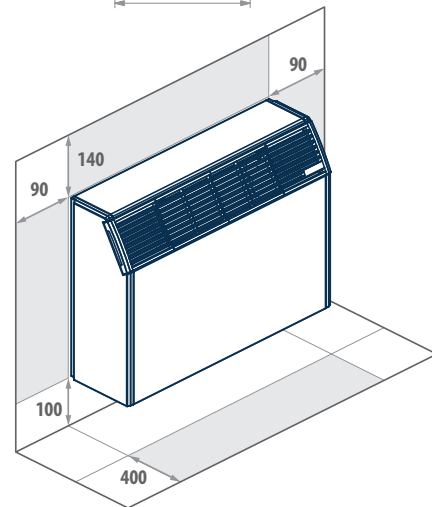
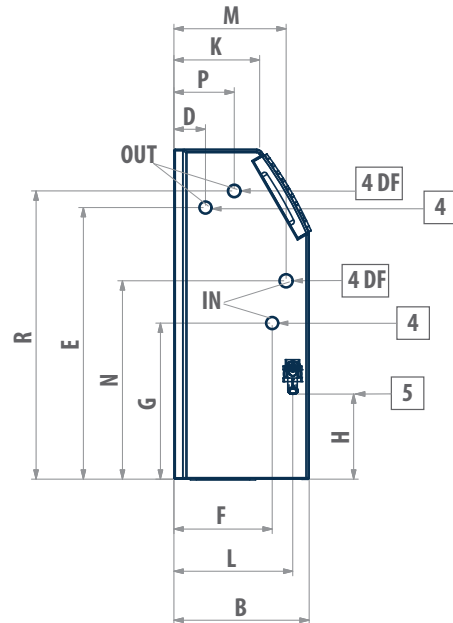
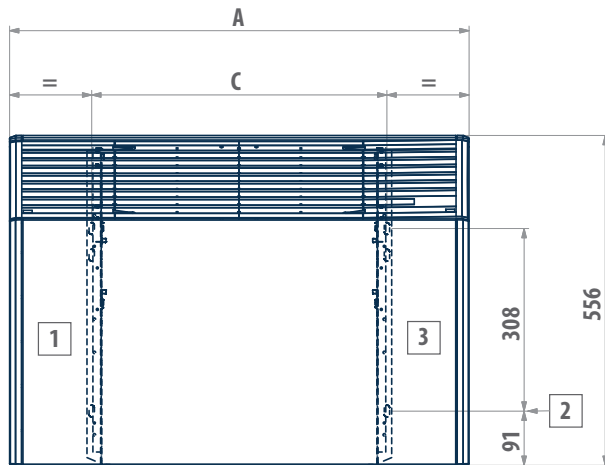
ESTRO FA

LEGEND

1	Usable space for plumbing connections
2	Slots for installation on the wall
3	Usable space for electrical connections
4	Standard heat exchanger water connections
4DF	DF 1-row DF additional heat exchanger water connections
5	Condensate drainage

ESTRO FA	1	2	3	4	4M	5	6	6M	7	7M	8	8M	9	9M	10	10M	11	11M	12	
ON/OFF motor (3 speed)	x	x	x	x	x	x	x	x	x	x	x	x	x	x	x	x	x	x	x	x
Inverter-controlled motor	x	-	x	x	x	x	x	x	x	-	x	-	x	x	-	-	x	x	-	

x = available

ESTRO	A	B	C	D	E	F	G	H	K	L	M	N	P	R	4	4DF	5	
	mm	mm	mm	mm	mm	mm	mm	mm	mm	mm	mm	mm	mm	mm	"	"	mm	kg
1 - 2 - 3 - 4 - 4M	774	228	498	53	458	166	263	149	145	198	187	335	99	486	1/2	1/2	16	22
5 - 6 - 6M	984	228	708	53	458	166	263	149	145	198	187	335	99	486	1/2	1/2	16	26
7 - 7M - 8 - 8M - 9 - 9M	1194	228	918	53	458	166	263	149	145	198	187	335	99	486	1/2	1/2	16	32
10 - 10M - 11 - 11M	1404	253	1128	50	497	188	259	155	170	220	195	348	120	478	3/4	1/2	16	42
12	1614	253	1338	50	497	188	259	155	170	220	195	348	120	478	3/4	1/2	16	50

DIMENSIONAL DRAWINGS

ESTRO FU

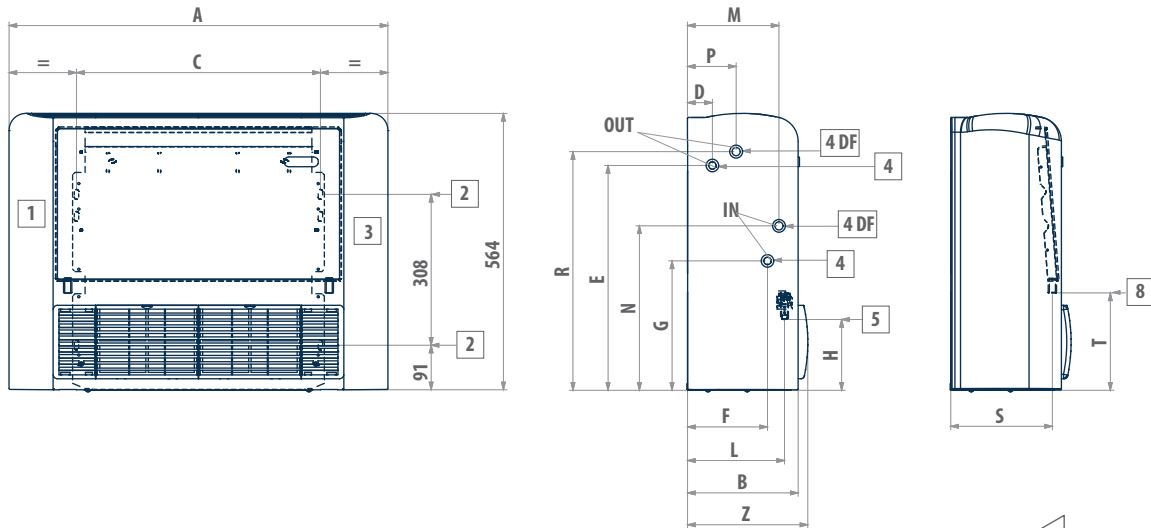

LEGEND

1	Usable space for plumbing connections
2	Slots for installation on the wall
3	Usable space for electrical connections
4	Standard heat exchanger water connections
4DF	DF 1-row DF additional heat exchanger water connections
5	Condensate drainage vertical installation
8	Condensate drainage horizontal installation

ESTRO FU	1	2	3	4	4M	5	6	6M	7	7M	8	8M	9	9M	95	10	10M	11	11M	12	
ON/OFF motor (3 speed)	x	x	x	x	x	x	x	x	x	x	x	x	x	x	x	x	x	x	x	x	x
Inverter-controlled motor	x	-	x	x	x	x	x	x	x	-	x	-	x	x	x	-	-	x	x	-	-

x = available

ESTRO FU	A	B	C	D	E	F	G	H	L	M	N	P	R	S	T	Z	4	kg
	mm	mm	mm	mm	mm	mm	mm	mm	mm	mm	mm	mm	mm	mm	mm	mm	"	kg
1 - 2 - 3 - 4 - 4M	774	226	498	51	458	163	263	149	198	187	335	99	486	208	198	246	1/2	22
5 - 6 - 6M	984	226	708	51	458	163	263	149	198	187	335	99	486	208	198	246	1/2	29
7 - 7M - 8 - 8M - 9 - 9M	1194	226	918	51	458	163	263	149	198	187	335	99	486	208	198	246	1/2	35
95	1194	251	918	48	497	185	259	155	220	195	348	120	478	234	208	271	3/4	36
10 - 10M - 11 - 11M	1404	251	1128	48	497	185	259	155	220	195	348	120	478	234	208	271	3/4	45
12	1614	251	1338	48	497	185	259	155	220	195	348	120	478	234	208	271	3/4	55

DIMENSIONAL DRAWINGS

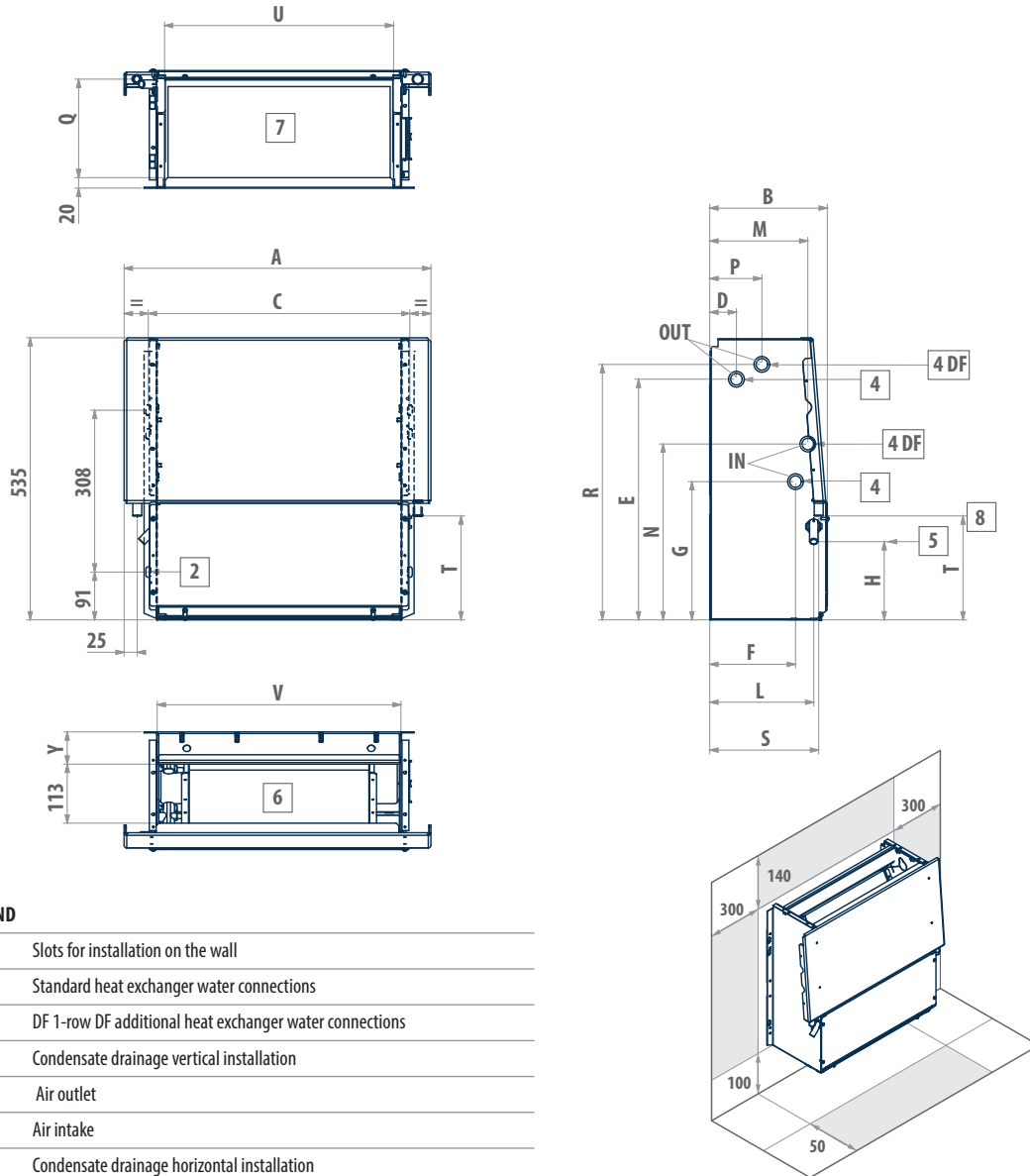
ESTRO FC

LEGEND

2	Slots for installation on the wall
4	Standard heat exchanger water connections
4DF	DF 1-row DF additional heat exchanger water connections
5	Condensate drainage vertical installation
6	Air outlet
7	Air intake
8	Condensate drainage horizontal installation

ESTRO FC	1	2	3	4	4M	5	6	6M	7	7M	8	8M	9	9M	95	10	10M	11	11M	12	
ON/OFF motor (3 speed)	x	x	x	x	x	x	x	x	x	x	x	x	x	x	x	x	x	x	x	x	x
Inverter-controlled motor	x	-	x	x	x	x	x	x	x	-	x	-	x	x	x	-	-	x	x	x	

x = available

ESTRO	A	B	C	D	E	F	G	H	L	M	N	P	Q	R	S	T	U	V	Y	4	kg
	mm	mm	mm	mm	mm	mm	mm	mm	mm	mm	mm	mm	mm	mm	mm	mm	mm	mm	mm	"	kg
1 - 2 - 3 - 4 - 4M	584	224	498	51	458	163	263	149	198	187	335	99	189	486	208	198	436	464	61	1/2	18
5 - 6 - 6M	794	224	708	51	458	163	263	149	198	187	335	99	189	486	208	198	646	674	61	1/2	23
7 - 7M - 8 - 8M - 9 - 9M	1004	224	918	51	458	163	263	149	198	187	335	99	189	486	208	198	856	884	61	1/2	27
95	1004	249	918	48	497	185	259	155	220	195	348	120	215	478	234	208	856	884	67	3/4	27
10 - 10M - 11 - 11M	1214	249	1128	48	497	185	259	155	220	195	348	120	215	478	234	208	1066	1094	67	3/4	37
12	1424	249	1338	48	497	185	259	155	220	195	348	120	215	478	234	208	1276	1304	67	3/4	43

Fan coil units with centrifugal fan and EC motor

ESTRO i 1 - 9 kW



EC motor



2 pipes systems



4 pipes systems



Vertical installation



Centrifugal fan



Horizontal installation

Energy savings and comfort in a single solution

The continual innovation that characterizes the design of ESTRO has resulted in fan assemblies with inverter-controlled permanent magnet EC motors.

The use of this type of motor makes it possible to achieve a major reduction in power consumption, better perceived comfort in terms of temperature and humidity. Analyses and verifications have shown a reduction in consumption of no less than 70% with integrated operation compared to traditional AC motors, with a corresponding reduction in CO₂ emissions.

The DC Inverter technology allows to continuously adjust the air flow to the actual needs of the environment by considerably reducing the fluctuations in room temperature that are typical of step-by-step adjustments. The continuous modulation of air flow brings about an adjustment in the delivered heating capacity, so that the interior is brought quickly to the set conditions and the noise levels are exceptionally low while they are being maintained.

ESTRO i fan coil units MYCOMFORT LARGE and EVO microprocessor control panels, which, thanks to the analogue outputs and refined adjustment logics, perfectly control the operation of the EC motors and modulating valves.

PLUS

- » Inverter-controlled EC motor
- » Low energy consumption
- » Modulating operation
- » Extremely quiet operation
- » Heat exchanger up to 4 rows



AVAILABLE VERSIONS

ESTRO FL i Wall mounted with cabinet
ESTRO FA i Wall recess mounted with cabinet

ESTRO FU i Floor and ceiling mounted with cabinet
ESTRO FC i Vertical / horizontal recess mounted with rear air intake

MAIN COMPONENTS

Cabinet

Composed of a painted steel sheet panel, side panels, air outlet grille (swinging by 180°) and back suction grille built from ABS.

Structure

Built from galvanised steel sheet of extra thickness, heat and sound insulated by means of Class 1 self-extinguishing panels. FUi and FCi versions are suitable for either vertical or horizontal installation thanks to the dual condensate collection and drainage system.

Heat exchanger

High efficiency heat exchanger made with copper piping and aluminium fins, provided with brass manifolds and vent valve. The water connections are reversible at the time of installation. On request it is possible to mount an additional heat exchanger for 4-pipe systems.

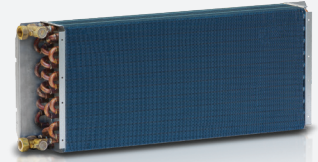

Fans

Double suction centrifugal fans, statically and dynamically balanced, manufactured from anti-static ABS, with blades having an airfoil section and offset modules. The fans are housed in a low-noise ABS volute with high-efficiency profile.

EC electric motor

Permanent magnet motor The unit is equipped with an inverter board to control the motor, that makes it possible to precisely set the maximum rotation speed of the motor (control signal 0-10 V).

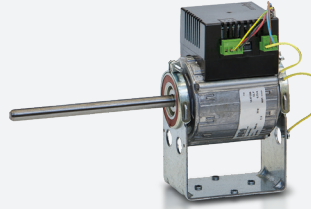

Air filter

Honey-comb polypropylene washable air filter, easily removable for maintenance operations. On FUi version the air filters are fitted onto the air inlet grille.

ACCESSORIES

Electronic microprocessor control panels with display

DIST	MYCOMFORT controller spacer for wall mounting
EVO-2-TOUCH	2.8" touch screen user interface for EVO control
EVOBOARD	Circuit board for EVO control
EVO DISP	User interface with display for EVO controller
EYNAVEL	Device for Wi-Fi or Bluetooth communication between EVOBOARD and smartphone
KBE	MY COMFORT on-board installation kit
MCLE	Microprocessor control with display MYCOMFORT LARGE
MCSUE	Humidity sensor for MYCOMFORT LARGE and EVO
MCSWE	Water sensor for MYCOMFORT and EVO controllers

Electronic microprocessor control panels

KB A	On-board ESTRO FA installation kit suitable for TED controller
KB L DX	On-board ESTRO FL/FU/FB installation kit on the right side suitable for TED controller
KB L SX	On-board ESTRO FL/FU/FB installation kit on the left side suitable for TED controller
TED 10	Electronic controller for EC fan equipped with inverter and ON/OFF valves 230 V
TED SWA	Water temperature sensor for TED controls

Power interface and regulating louver controllers

CSB	On-board controller for opening and closing the motor-driven regulating louver
CSD	Recess mounted controller for opening and closing the SM motor-driven regulating louver

Additional heat exchanger for 4-pipe systems

DF	1-row additional heat exchanger for 4-pipe systems (not suitable for ESTRO "M" models)
-----------	--

Auxiliary water drip trays, insulating shell, condensate drainage pump

BH	Auxiliary water drip tray for horizontal installation fan coil units
BV	Auxiliary water drip tray for vertical installation fan coil units
GIVKL	Insulating shell for VKS valve, water connections on the left
GIVKR	Insulating shell for VKS valve, water connections on the right
KSC	Condensate drainage pump kit

Base and enclosure elements

ZA	Pair of support covering elements with front grille for ESTRO FA
ZAG	Pair of support covering elements for ESTRO FA

ZL	Pair of support covering elements for ESTRO FL
ZLG	Pair of support covering elements with front grille for ESTRO FL

Rear covering panels

PH	Rear painted panel for horizontal installation with cabinet
PV	Rear painted panel for vertical installation with cabinet

Air inlet and outlet grilles

GE	Aluminium external air intake grille with subframe
GEF	Aluminium external air intake grille with subframe and air filter
GM	Aluminium air outlet grille with 2-row fins and subframe
RGC	Plenum with circular collars for air outlet grille

Plenum and connectors

RA90	Angular inlet connector
RAD	Straight inlet connector
RADC	Air inlet plenum with circular collars
RM90	Angular outlet connector
RM90C	Angular outlet insulated connector
RMCD	Straight outlet insulated connector
RMCD C	Air outlet plenum with circular collars
RMD	Straight outlet connector

External air intake louvers

SM	Motor-driven louver, with motor on the right with transformer
SM	Motor-driven louver, with motor on the left with transformer
SM	Motorized air intake louver
SMC	Motor driven louver, with motor on the right, with transformer
SMC	Motor driven louver, with motor on the left, with transformer

Valves

KV	2-way valve, ON/OFF actuator, hydraulic kit on water connection side for main heat exchanger
KVM	2-way valve, MODULATING actuator, 24 V power supply, hydraulic kit on water connection side for main heat exchanger
VPIC	2-way valves pressure independent, ON/OFF or MODULATING actuator, 230 V or 24 V power supply, hydraulic kit, for main heat exchanger

2 PIPES - RATED TECHNICAL DATA

ESTRO i			1			3			4			4M		
Speed			min	med	max	min	med	max	min	med	max	min	med	max
Control voltage	(E)	V	4,00	5,30	6,50	5,20	6,90	8,40	5,20	6,90	8,40	5,20	6,90	8,40
Total cooling capacity	(1)(E)	kW	0,77	0,91	1,14	1,25	1,51	1,72	1,35	1,69	1,94	1,49	1,84	2,22
Sensible cooling capacity	(1)(E)	kW	0,59	0,69	0,86	0,94	1,13	1,28	1,04	1,30	1,49	1,05	1,31	1,58
FCEER class	(E)		B											
Water flow	(2)	l/h	133	157	196	215	260	296	232	291	334	257	317	382
Water pressure drop	(2)(E)	kPa	4	5	7	8	11	14	7	10	13	10	14	20
Heating capacity	(3)(E)	kW	0,95	1,11	1,32	1,45	1,72	1,84	1,50	1,81	2,15	1,53	1,88	2,29
FCCOP class	(E)		C			B			B			C		
Water flow	(3)	l/h	164	191	227	250	296	317	258	312	370	263	324	394
Water pressure drop	(3)(E)	kPa	5	6	8	9	12	14	6	9	12	9	12	17
Rated air flow		m ³ /h	149	189	231	211	271	344	211	271	344	211	271	344
Power input	(E)	W	6	8	9	7	9	19	7	9	19	9	12	24
Total sound power level	(4)(E)	dB(A)	30	32	40	38	44	49	40	44	50	41	45	51

ESTRO i			5			6			6M			7		
Speed			min	med	max	min	med	max	min	med	max	min	med	max
Control voltage	(E)	V	3,80	5,70	7,30	3,80	5,70	7,30	3,80	5,70	7,30	3,60	5,40	8,00
Total cooling capacity	(1)(E)	kW	1,59	2,02	2,40	1,75	2,37	2,91	1,92	2,63	3,27	1,97	2,62	3,49
Sensible cooling capacity	(1)(E)	kW	1,17	1,56	1,86	1,25	1,69	2,09	1,32	1,82	2,28	1,44	2,03	2,73
FCEER class	(E)		A			A			A			C		
Water flow	(2)	l/h	274	348	413	301	408	501	331	453	563	339	451	601
Water pressure drop	(2)(E)	kPa	8	12	16	5	8	11	7	12	17	4	7	12
Heating capacity	(3)(E)	kW	1,74	2,26	2,70	1,76	2,37	2,94	1,74	2,41	3,03	2,39	3,13	4,05
FCCOP class	(E)		A			A			B			C		
Water flow	(3)	l/h	300	389	465	303	408	506	300	415	522	412	539	697
Water pressure drop	(3)(E)	kPa	8	12	17	5	8	11	6	10	15	5	8	13
Rated air flow		m ³ /h	241	341	442	241	341	442	241	341	442	320	450	640
Power input	(E)	W	6	8	16	8	10	20	6	8	16	10	17	34
Total sound power level	(4)(E)	dB(A)	35	43	48	36	42	48	35	43	49	35	46	52

ESTRO i			8			9			9M			95		
Speed			min	med	max	min	med	max	min	med	max	min	med	max
Control voltage	(E)	V	3,70	5,40	8,00	5,00	6,70	8,90	5,00	6,70	8,90	4,80	6,10	8,30
Total cooling capacity	(1)(E)	kW	2,50	3,26	4,30	2,99	3,64	4,48	3,51	4,35	5,37	3,41	4,17	5,22
Sensible cooling capacity	(1)(E)	kW	1,79	2,44	3,12	2,31	2,90	3,62	2,46	3,05	3,79	2,47	3,11	3,95
FCEER class	(E)		A			B			A			A		
Water flow	(2)	l/h	430	561	740	515	627	771	604	749	925	587	718	899
Water pressure drop	(2)(E)	kPa	6	10	15	7	10	14	11	16	24	10	14	21
Heating capacity	(3)(E)	kW	2,47	3,24	4,24	3,36	4,11	4,88	3,53	4,37	5,39	3,52	4,32	5,49
FCCOP class	(E)		B											
Water flow	(3)	l/h	425	558	730	579	708	840	608	753	928	606	744	945
Water pressure drop	(3)(E)	kPa	5	8	14	7	9	13	10	14	20	8	12	18
Rated air flow		m ³ /h	361	497	706	470	605	785	470	605	785	488	615	814
Power input	(E)	W	10	13	27	15	20	41	17	23	47	15	18	43
Total sound power level	(4)(E)	dB(A)	35	43	53	43	49	56	44	50	57	44	51	58

(1) Water temperature 7°C / 12°C, air temperature dry bulb 27°C, wet bulb 19°C (47% relative humidity) according to EN1397:2021

(2) Water temperature 7°C / 12°C, air temperature dry bulb 27°C, wet bulb 19°C (47% relative humidity)

(3) Water temperature 45°C / 40°C, air temperature 20°C

(4) Sound power measured according to standards ISO 3741 and ISO 3742

(E) EUROVENT certified data

Power supply 230-1-50 (V-ph-Hz)

NOTE: The dimensional drawings of the ESTRO i inverter units are the same of the ESTRO ON/OFF version. They are reported from page 46

2 PIPES - RATED TECHNICAL DATA

ESTRO i			11			11M		
Speed			min	med	max	min	med	max
Control voltage	(E)	V	3,60	6,20	8,60	3,60	6,20	8,60
Total cooling capacity	(1)(E)	kW	4,11	6,24	8,02	4,65	6,94	8,89
Sensible cooling capacity	(1)(E)	kW	3,05	4,63	5,96	3,28	4,91	6,30
FCEER class	(E)		B			A		
Water flow	(2)	l/h	708	1075	1381	801	1195	1531
Water pressure drop	(2)(E)	kPa	6	13	20	9	19	29
Heating capacity	(3)(E)	kW	4,39	6,53	8,37	4,75	7,02	9,00
FCCOP class	(E)		B					
Water flow	(3)	l/h	756	1124	1441	818	1209	1550
Water pressure drop	(3)(E)	kPa	6	12	18	8	16	25
Rated air flow		m ³ /h	642	1022	1393	642	1022	1393
Power input	(E)	W	17	50	114	13	38	87
Total sound power level	(4)(E)	dB(A)	49	60	67	50	61	68

(1) Water temperature 7°C / 12°C, air temperature dry bulb 27°C, wet bulb 19°C (47% relative humidity) according to EN1397:2021

(2) Water temperature 7°C / 12°C, air temperature dry bulb 27°C, wet bulb 19°C (47% relative humidity)

(3) Water temperature 45°C / 40°C, air temperature 20°C

(4) Sound power measured according to standards ISO 3741 and ISO 3742

(E) EUROVENT certified data

Power supply 230-1-50 (V-ph-Hz)

NOTE: The dimensional drawings of the ESTRO i inverter units are the same of the ESTRO ON/OFF version. They are reported from page 46

4 PIPES - RATED TECHNICAL DATA

ESTRO i			1			3			4			5		
Speed			min	med	max	min	med	max	min	med	max	min	med	max
Control voltage	(E)	V	4,00	5,30	6,50	5,10	6,60	8,10	5,10	6,60	8,10	3,70	5,50	7,20
Total cooling capacity	(1)(E)	kW	0,75	0,89	1,12	1,23	1,47	1,67	1,25	1,55	1,77	1,57	1,99	2,37
Sensible cooling capacity	(1)(E)	kW	0,57	0,68	0,85	0,92	1,10	1,25	0,97	1,21	1,44	1,16	1,53	1,84
FCEER class	(E)		C			B			B			A		
Water flow	(2)	l/h	129	153	193	212	253	288	215	267	305	270	343	408
Water pressure drop	(2)(E)	kPa	4	5	7	8	11	14	7	10	13	8	12	16
Heating capacity	(3)(E)	kW	1,18	1,31	1,49	1,36	1,56	1,76	1,36	1,56	1,76	1,78	2,18	2,53
FCCOP class	(E)		B			B			B			B		
Water flow	(3)	l/h	102	113	128	117	134	152	117	134	152	153	188	218
Water pressure drop	(3)(E)	kPa	2	3	4	4	5	7	4	5	6	2	3	3
Rated air flow		m ³ /h	146	184	226	205	261	330	205	261	327	238	334	432
Power input	(E)	W	7	8	9	7	8	18	7	8	18	8	10	19
Total sound power level	(4)(E)	dB(A)	29	32	40	40	44	49	38	44	50	34	43	48

ESTRO i			6			7			8		
Speed			min	med	max	min	med	max	min	med	max
Control voltage	(E)	V	3,80	5,70	7,30	3,60	5,40	8,00	3,70	5,40	8,00
Total cooling capacity	(1)(E)	kW	1,72	2,32	2,86	1,95	2,59	3,44	2,47	3,22	4,24
Sensible cooling capacity	(1)(E)	kW	1,23	1,65	2,06	1,43	2,01	2,69	1,77	2,41	3,07
FCEER class	(E)		A								
Water flow	(2)	l/h	296	400	492	336	446	592	425	554	730
Water pressure drop	(2)(E)	kPa	5	8	11	4	7	12	5	7	12
Heating capacity	(3)(E)	kW	1,88	2,31	2,68	2,82	3,47	4,20	2,73	3,22	3,82
FCCOP class	(E)		B			B			A		
Water flow	(3)	l/h	162	199	231	243	299	362	235	277	329
Water pressure drop	(3)(E)	kPa	2	3	4	8	12	16	8	10	14
Rated air flow		m ³ /h	237	332	431	316	444	628	356	490	690
Power input	(E)	W	6	11	17	9	12	17	9	13	25
Total sound power level	(4)(E)	dB(A)	33	41	47	36	45	53	39	46	56

- (1) Water temperature 7°C / 12°C, air temperature dry bulb 27°C, wet bulb 19°C (47% relative humidity) according to EN1397:2021
(2) Water temperature 7°C / 12°C, air temperature dry bulb 27°C, wet bulb 19°C (47% relative humidity)
(3) Water temperature 65°C / 55°C, air temperature 20°C
(4) Sound power measured according to standards ISO 3741 and ISO 3742
(E) EUROVENT certified data

NOTE: The dimensional drawings of the ESTRO i inverter units are the same of the ESTRO ON/OFF version. They are reported from page 46

4 PIPES - RATED TECHNICAL DATA

ESTRO i			9			95			11		
Speed			min	med	max	min	med	max	min	med	max
Control voltage	(E)	V	5,00	6,70	8,70	4,80	6,10	8,30	3,60	6,20	8,60
Total cooling capacity	(1)(E)	kW	3,10	3,79	4,64	3,53	4,32	5,39	3,76	5,67	7,20
Sensible cooling capacity	(1)(E)	kW	2,27	2,85	3,54	2,42	3,06	3,86	3,00	4,52	5,73
FCEER class	(E)		B			B			B		
Water flow	(2)	l/h	534	653	799	608	744	928	647	976	1240
Water pressure drop	(2)(E)	kPa	7	10	14	10	14	20	5	10	16
Heating capacity	(3)(E)	kW	3,55	4,07	4,64	3,70	4,20	4,84	4,85	6,29	7,35
FCCOP class	(E)		C								
Water flow	(3)	l/h	306	350	400	319	362	417	418	542	633
Water pressure drop	(3)(E)	kPa	7	8	11	7	9	12	14	22	29
Rated air flow		m ³ /h	460	593	763	478	603	792	636	1007	1362
Power input	(E)	W	19	24	46	22	27	57	18	51	116
Total sound power level	(4)(E)	dB(A)	46	52	56	46	52	59	48	58	66

(1) Water temperature 7°C / 12°C, air temperature dry bulb 27°C, wet bulb 19°C (47% relative humidity) according to EN1397:2021

(2) Water temperature 7°C / 12°C, air temperature dry bulb 27°C, wet bulb 19°C (47% relative humidity)

(3) Water temperature 65°C / 55°C, air temperature 20°C

(4) Sound power measured according to standards ISO 3741 and ISO 3742

(E) EUROVENT certified data

NOTE: The dimensional drawings of the ESTRO i inverter units are the same of the ESTRO ON/OFF version. They are reported from page 46

Fan coil unit with design cabinet, 17 cm in depth

FLAT S 1 - 3 kW



The solution tailored to design requirements of residential applications

Galletti's FLAT series now becomes SLIM. In fact, with a depth of only 17 cm, FLAT S ensures a compact size that makes it easy to integrate in any context, thus responding to the new design trends in the residential sector (and beyond).

The FLAT S mini series means innovation also in terms of engineering: it combines a guarantee of excellent low-noise performance with the advantage of an exclusive design that fits well with both residential and commercial settings.

The stylishly designed cabinet (colour RAL9010) is compact and manufactured from steel sheet and UV-stabilised ABS. The upper grille includes a flap and adjustable louvers fitted with a microswitch that automatically shuts down the unit when the flap itself is closed.

The adoption of UV-stabilized ABS in the parts making up the cabinet and antistatic ABS in the fan assembly (volute and centrifugal fan) guarantee that the product will maintain the same aesthetics and noise levels throughout its lifetime.



PLUS

- » Cabinet with a refined design, depth 17 cm
- » Microswitch on air flap
- » Use of UV-stabilized ABS
- » Reversible water connections
- » 3-speed motor
- » ABS centrifugal fans



MAIN COMPONENTS

Cabinet

Design cabinet, RAL9010 colour, only 17 cm in depth, front panel made of sheet steel. Side panels and an upper grille with covers on either side manufactured from UV-stabilised ABS to maintain the colour intact over time. The upper grille consists of a flap and adjustable louvers. The flap features a microswitch that automatically shuts down the unit when the flap itself is closed.



Structure

Built from galvanised steel sheet of extra thickness, heat and sound insulated by means of Class 1 self-extinguishing panels.

Heat exchanger

High efficiency heat exchanger made with copper piping and aluminium fins, provided with brass manifolds and vent valve. The water connections are reversible at the time of installation. On request it is possible to mount an additional heat exchanger for 4-pipe systems.

Fans

Double suction centrifugal fans, statically and dynamically balanced, manufactured from anti-static ABS, with blades having an airfoil section and offset modules. The fans are housed in a low-noise ABS volute with high-efficiency profile.

Electric motor

It is mounted on vibration dampers, with permanently activated capacitor and thermal protection of the windings, and is directly coupled with the fans. It is available with 3 rotation speeds to meet all specific requirements in terms of performance, noise levels, and power consumption.

Air filter

Honey-comb polypropylene washable air filter, easily removable for maintenance operations.

CONFIGURATOR

The models are completely configurable by selecting the version and the options. To the right is shown an example of configuration.

Version	Field	1	2	3	4	5	6	7	8	9	10	11
FLATS13		L	0	M	0	1	E	0	0	0	0	A

To verify the compatibility of the options, use the selection software or the price list.

CONFIGURATOR

- 1 Version**
 - L - Wall mounted with cabinet
- 2 Motor**
 - 0 3-speed motor
 - I EC motor
- 3 Main coil hydraulic side**
 - L Water connections on the left side
 - R Water connections on the right
- 4 Additional coil hydraulic side / heating element**
 - 0 Absent
 - L Water connections on the left side
 - R Water connections on the right
- 5 Valve**
 - 0 Absent
 - 1 VKS - 3 ways valve - 230 V - ON/OFF - complete hydraulic kit
 - 2 KV - 2 ways valve - 230 V - ON/OFF
 - 3 VKMS - 3 ways valve - 24 V - MODULATING - complete hydraulic kit
 - 4 KVM - 2 ways valve - 24 V - MODULATING
 - 5 VKS24 - 3 way valve - 24 V - ON/OFF - complete hydraulic kit
 - 6 KV24 - 2 way valve - 24 V - ON/OFF
 - A VKSND - 3 way valve - 230 V - ON/OFF - hydraulic kit on coil side
 - B VKMSND - 3 ways valve - 24 V - MODULATING - hydraulic kit on coil side
 - C VKS24ND - 3 ways valve - 24 V - ON/OFF - hydraulic kit on coil side
- 6 Control panel**
 - 0 Absent
 - 1 CB - On-board speed selector
 - 3 TIB - Speed selector, thermostat and S/W selecting switch
 - 4 TED 2T - microprocessor control for 2 pipes
 - 5 TED 4T - microprocessor control for 4 pipes
 - 6 TED 10 - microprocessor control for EC
- 7 Probes**
 - 0 Absent
 - 1 SA - Remote air probe for MYCOMFORT and EVO
 - 2 SW - Water probe for MYCOMFORT and EVO
 - 3 SU - Humidity probe for MYCOMFORT and EVO
 - 4 SA+SW - Remote air and water probes for MYCOMFORT and EVO
 - 5 SA+SU - Remote air and humidity probes for MYCOMFORT and EVO
 - 6 SA+SU+SW - Remote air, water, humidity probes for MYCOMFORT and EVO
 - A TC - Thermostat for minimum water temperature
 - B SA - Remote air probe for TED
 - C SW - Water probe for TED
 - D SA + SW - Air and water probes for TED
- 8 Accessories**
 - 0 Absent
 - 4 BV - Auxiliary drip tray
 - 6 GIVK - Insulating shell
- 9 Filter**
 - 0 Standard filter air
- 10 Release**
 - 0 0
 - A A

ACCESSORIES

Electromechanical control panels	
CB	On-board speed switch
TC	Thermostat for minimum water temperature in heating mode (42 °C)
TIB	On-board speed switch, thermostat and summer/winter selecting switch
Electronic microprocessor control panels with display	
DIST	MYCOMFORT controller spacer for wall mounting
EVO-2-TOUCH	2.8" touch screen user interface for EVO control
EVOBOARD	Circuit board for EVO control
EVODISP	User interface with display for EVO controller
EYNAVEL	Device for Wi-Fi or Bluetooth communication between EVOBOARD and smartphone
KBFLAE	MY COMFORT on-board installation KIT for FLAT
MCBE	MYCOMFORT BASE electronic controller with display
MCLE	Microprocessor control with display MYCOMFORT LARGE
MCSUE	Humidity sensor for MYCOMFORT LARGE and EVO controller
MCSWE	Water sensor for MYCOMFORT and EVO controllers
Electronic microprocessor control panels	
KB F	On-board FLAT/FLAT S installation kit suitable for TED controller
TED 2T	Electronic controller for AC fan control and one ON/OFF 230 V valve
TED 4T	Electronic controller for AC fan control and two ON/OFF 230 V valves
TED SWA	Water temperature sensor for TED controls
Power interface and regulating lower controllers	
KP	Power interface for connecting in parallel up to 4 fun coil units to the one controller
Additional heat exchanger for 4-pipe systems	
DF	1-row additional coil for 4 pipes system
Auxiliary water drip trays, insulating shell, condensate drainage pump	
BVK	Auxiliary water drip tray for vertical installation fan coil units
GIVKL	Insulating shell for VKS valve, water connections on the left
GIVKR	Insulating shell for VKS valve, water connections on the right
Base and enclosure elements	
ZLS	Pair of base and enclosure elements for FLAT S
Rear covering panels	
PV	Rear painted panel for vertical installation with cabinet
Valves	
KV	2-way valve, ON/OFF actuator, hydraulic kit on water connection side for main heat exchanger
KV24DF	2-way valve, ON/OFF actuator, 24 V power supply, hydraulic kit on water connection side for main and additional heat exchanger
V2VDF+STD	2-way valves, ON/OFF or MODULATING actuator, 230 V or 24 V power supply, hydraulic kit, for main and additional heat exchanger
V2VSTD	2-way valve, ON/OFF or MODULATING actuator, 230 V or 24 V power supply, hydraulic kit, for main heat exchanger
V3VDF	3-way valves, ON/OFF or MODULATING actuator, 230 V or 24 V power supply, hydraulic kit, for additional heat exchanger
V3VSTD	2-way valves, ON/OFF or MODULATING actuator, 230 V or 24 V power supply, hydraulic kit, for main heat exchanger
VKDF24	3-way valve, ON/OFF actuator, 24 V power supply, complete hydraulic kit for additional heat exchanger
VKMS	3-way valve, MODULATING actuator, 24 V power supply, complete hydraulic kit for main heat exchanger
VKMSND	3-way valve, MODULATING actuator, 24 V power supply, hydraulic kit without holder, for main heat exchanger
VKSND	3-way valve, ON/OFF actuator, 230 V power supply, hydraulic kit without holder, for main heat exchanger
VPIC	2-way valves pressure independent, ON/OFF actuator, 230 V power supply, hydraulic kit, for main heat exchanger

2 PIPES - RATED TECHNICAL DATA

FLAT S			13			23			33			43		
Speed			min	med	max	min	med	max	min	med	max	min	med	max
Total cooling capacity	(1)(E)	kW	0,85	0,96	1,22	0,99	1,22	1,58	1,39	1,73	2,28	1,74	2,11	2,74
Sensible cooling capacity	(1)(E)	kW	0,60	0,68	0,87	0,74	0,91	1,19	1,00	1,24	1,65	1,25	1,52	1,99
FCEER class	(E)		D											
Water flow	(2)	l/h	148	168	213	173	214	277	243	303	399	303	369	479
Water pressure drop	(2)(E)	kPa	3	3	5	5	7	11	3	5	7	5	7	10
Heating capacity	(3)(E)	kW	0,81	0,92	1,16	1,00	1,22	1,59	1,52	1,85	2,40	1,85	2,22	2,86
FCCOP class	(E)		E											
Water flow	(3)	l/h	141	160	201	174	211	277	264	321	417	321	386	497
Water pressure drop	(3)(E)	kPa	2	3	4	4	7	12	3	4	7	4	6	9
Rated air flow		m ³ /h	115	135	170	135	170	225	200	250	340	250	310	420
Power input	(E)	W	12	17	23	16	23	31	26	32	42	29	35	48
Total sound power level	(4)(E)	dB(A)	30	35	40	35	40	46	32	38	46	37	42	49

(1) Water temperature 7°C / 12°C, air temperature dry bulb 27°C, wet bulb 19°C (47% relative humidity) according to EN1397:2021

(2) Water temperature 7°C / 12°C, air temperature dry bulb 27°C, wet bulb 19°C (47% relative humidity)

(3) Water temperature 45°C / 40°C, air temperature 20°C

(4) Sound power measured according to standards ISO 3741 and ISO 3742

(E) EUROVENT certified data

Power supply 230-1-50 (V-ph-Hz)

4 PIPES - RATED TECHNICAL DATA

FLAT S			13			23			33			43		
Speed			min	med	max	min	med	max	min	med	max	min	med	max
Total cooling capacity	(1)(E)	kW	0,85	0,96	1,22	1,08	1,33	1,72	1,40	1,74	2,29	1,75	2,12	2,75
Sensible cooling capacity	(1)(E)	kW	0,60	0,68	0,87	0,74	0,91	1,19	1,00	1,24	1,65	1,25	1,52	1,99
FCEER class	(E)		D											
Water flow	(2)	l/h	148	168	213	186	230	300	243	303	399	303	368	477
Water pressure drop	(2)(E)	kPa	3	3	5	5	7	11	3	5	7	5	7	10
Heating capacity	(3)(E)	kW	1,04	1,15	1,36	1,35	1,56	1,91	1,88	2,16	2,69	2,16	2,45	3,02
FCCOP class	(E)		D											
Water flow	(3)	l/h	91	100	119	118	136	167	165	189	235	189	215	264
Water pressure drop	(3)(E)	kPa	2	2	3	4	5	7	1	2	3	2	2	3
Rated air flow		m ³ /h	115	135	170	135	170	225	200	250	340	250	310	420
Power input	(E)	W	12	17	23	14	20	27	23	28	37	25	31	42
Total sound power level	(4)(E)	dB(A)	30	35	40	35	40	46	32	38	46	37	42	49

(1) Water temperature 7°C / 12°C, air temperature dry bulb 27°C, wet bulb 19°C (47% relative humidity) according to EN1397:2021

(2) Water temperature 7°C / 12°C, air temperature dry bulb 27°C, wet bulb 19°C (47% relative humidity)

(3) Water temperature 65°C / 55°C, air temperature 20°C

(4) Sound power measured according to standards ISO 3741 and ISO 3742

(E) EUROVENT certified data

Power supply 230-1-50 (V-ph-Hz)

DIMENSIONAL DRAWINGS

FLAT S

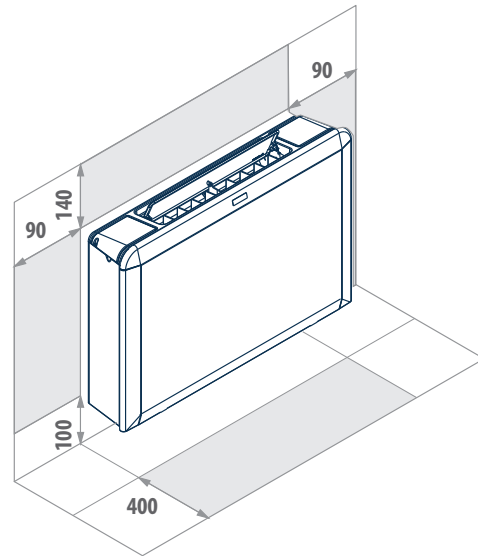
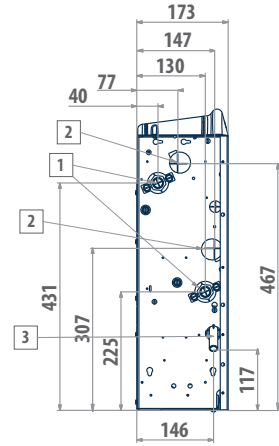
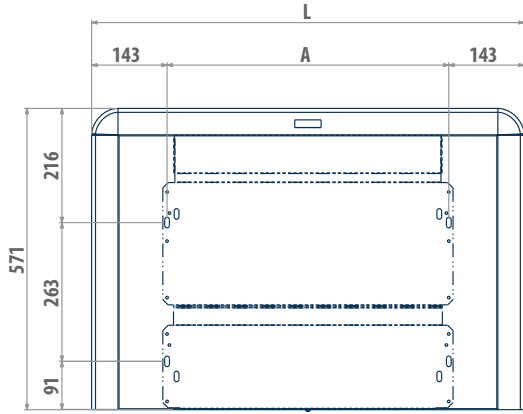

LEGEND

- 1 Water connections standard heat exchanger \varnothing 1/2"
 - 2 DF 1-row additional heat exchanger water connections \varnothing 1/2"
 - 3 Condensate discharge diameter for vertical installation \varnothing 16 mm
- Condensate discharge diameter for horizontal installation \varnothing 17 mm**

FLAT S	A mm	L mm	kg
13	534	820	17
23	704	990	21
33 - 43	874	1160	23

Fan coil unit with design cabinet, only 17 cm in depth and EC motor

FLAT S i 1 - 3 kW



EC motor



2 pipes systems



4 pipes systems



Vertical installation



Centrifugal fan

The solution tailored to design requirements of residential applications

Galletti's FLAT series now becomes SLIM. In fact, with a depth of only 17 cm, FLAT S ensures a compact size that makes it easy to integrate in any context, thus responding to the new design trends in the residential sector (and beyond).

The FLAT S mini series means innovation also in terms of engineering: it combines a guarantee of excellent low-noise performance with the advantage of an exclusive design that fits well with both residential and commercial settings.

The Galletti FLAT S i indoor hydronic units are equipped with a permanent magnet (brushless) electric motor, controlled by an inverter, which enables continuous adjustment in the number of fan revolutions.

In addition to the important reduction in electricity consumption compared to AC motors, the use of inverter EC technology makes it possible to continually adjust the operation of the unit to the actual thermo-hygrometric load of the interior, with a clear benefit in terms of comfort and reducing noise.

Its use is particularly effective in the frequent cases of operation under partial load conditions, the situation that occurs most frequently, when the adjustment logic allows greatly reduced motor rotation speeds with exceptional reductions in electricity consumption and noise emissions.

The operation of the unit with brushless motor is managed by EVO, MYCOMFORT LARGE or TED microprocessor control panel, using an analogue output (0-10 V) which is connected to the inverter.

PLUS

- » Cabinet with a refined design, depth 17 cm
- » Low energy consumption
- » Modulating operation
- » Microswitch on exit air flap
- » Reversible water connections
- » Inverter-controlled EC motor
- » ABS centrifugal fans



AVAILABLE VERSIONS



Suspended wall installation, with cabinet, with vertical air flow
2 and 4 pipes system

MAIN COMPONENTS

Cabinet

Design cabinet, RAL9010 colour, only 17 cm in depth, front panel made of sheet steel. Side panels and an upper grille with covers on either side manufactured from UV-stabilised ABS to maintain the colour intact over time. The upper grille consists of a flap and adjustable louvers. The flap features a microswitch that automatically shuts down the unit when the flap itself is closed.



Structure

Built from galvanised steel sheet of extra thickness, heat and sound insulated by means of Class 1 self-extinguishing panels.

Heat exchanger

High efficiency heat exchanger made with copper piping and aluminium fins, provided with brass manifolds and vent valve. The water connections are reversible at the time of installation. On request it is possible to mount an additional heat exchanger for 4-pipe systems.

Fans

Double suction centrifugal fans, statically and dynamically balanced, manufactured from anti-static ABS, with blades having an airfoil section and offset modules. The fans are housed in a low-noise ABS volute with high-efficiency profile.

Electric motor

The unit is equipped with an inverter board to control the motor, which can be used separately or installed on the motor itself. This system makes it possible to precisely set the maximum rotation speed of the motor (control signal 0-10 V) even when the maximum rotation speed must be controlled to reduce noise levels.



Air filter

Honey-comb polypropylene washable air filter, easily removable for maintenance operations.

ACCESSORIES

Electronic microprocessor control panels with display

DIST	MYCOMFORT controller spacer for wall mounting
EVO-2-TOUCH	2.8" touch screen user interface for EVO control
EVOBOARD	Circuit board for EVO control
EVODISP	User interface with display for EVO controller
EYNAVEL	Device for Wi-Fi or Bluetooth communication between EVOBOARD and smartphone
KBFLAE	MYCOMFORT on-board installation KIT for FLAT
MCLE	Microprocessor control with display MYCOMFORT LARGE
MCSUE	Humidity sensor for MYCOMFORT LARGE and EVO
MCSWE	Water sensor for MYCOMFORT and EVO controllers

Electronic microprocessor control panels

KB F	On-board FLAT/FLAT S installation kit suitable for TED controller
TED 10	Electronic controller for EC fan equipped with inverter and ON/OFF valves 230 V
TED SWA	Water temperature sensor for TED controls

Additional heat exchanger for 4-pipe systems

DF	1-row additional coil for 4 pipes system
-----------	--

Auxiliary water drip trays, insulating shell, condensate drainage pump

BV	Auxiliary water drip tray for vertical installation fan coil units
GIVKL	Insulating shell for VKS valve, water connections on the left
GIVKR	Insulating shell for VKS valve, water connections on the right

Base and enclosure elements

ZLS	Pair of base and enclosure elements for FLAT S
------------	--

Rear covering panels

PV	Rear painted panel for vertical installation with cabinet
-----------	---

Valves

KV	2-way valve, ON/OFF actuator, hydraulic kit on water connection side for main heat exchanger
KV24	2-way valve, ON/OFF actuator, 24 V power supply, hydraulic kit on water connection side for main heat exchanger
KV24DF	2-way valve, ON/OFF actuator, 24 V power supply, hydraulic kit on water connection side for main and additional heat exchanger

KVDF	2-way valve, ON/OFF actuator, 230 V power supply, hydraulic kit on water connection side for main and additional heat exchanger
KVM	2-way valve, MODULATING actuator, 24 V power supply, hydraulic kit on water connection side for main heat exchanger
KVMDF	2-way valve, MODULATING actuator, 24 V power supply, hydraulic kit on water connection side for main and additional heat exchanger
VKDF	3-way valve, ON/OFF actuator, 230 V power supply, complete hydraulic kit for additional heat exchanger
VKDF24	3-way valve, ON/OFF actuator, 24 V power supply, complete hydraulic kit for additional heat exchanger
VKDF24ND	3-way valve, ON/OFF actuator, 24 V power supply, hydraulic kit without holder, for additional heat exchanger
VKDFND	3-way valve, ON/OFF actuator, 230 V power supply, hydraulic kit without holder, for additional heat exchanger
VKMDF	3-way valve, MODULATING actuator, 24 V power supply, complete hydraulic kit for additional heat exchanger
VKMDFND	3-way valve, MODULATING actuator, 24 V power supply, hydraulic kit without holder, for additional heat exchanger
VKMS	3-way valve, MODULATING actuator, 24 V power supply, complete hydraulic kit for main heat exchanger
VKMSND	3-way valve, MODULATING actuator, 24 V power supply, hydraulic kit without holder, for main heat exchanger
VKS	3-way valve, ON/OFF actuator, 1230 V power supply, complete hydraulic kit for main heat exchanger
VKS24	3-way valve, ON/OFF actuator, 24 V power supply, complete hydraulic kit for main heat exchanger
VKS24ND	3-way valve, ON/OFF actuator, 24 V power supply, hydraulic kit without holder, for main heat exchanger
VKSND	3-way valve, ON/OFF actuator, 230 V power supply, hydraulic kit without holder, for main heat exchanger
VPIC	2-way valves pressure independent, ON/OFF actuator, 230 V power supply, hydraulic kit, for main heat exchanger

2 PIPES - RATED TECHNICAL DATA

FLAT S i			13			23			43		
Speed			min	med	max	min	med	max	min	med	max
Control voltage	(E)	V	4,80	5,80	7,70	4,50	5,80	7,90	5,10	6,30	8,00
Total cooling capacity	(1)(E)	kW	0,85	0,97	1,23	0,97	1,19	1,53	1,76	2,11	2,74
Sensible cooling capacity	(1)(E)	kW	0,60	0,69	0,88	0,74	0,93	1,20	1,26	1,52	1,99
FCEER class	(E)		D			B			B		
Water flow	(2)	l/h	148	168	213	168	230	300	303	368	477
Water pressure drop	(2)(E)	kPa	3	3	5	6	8	12	5	6	10
Heating capacity	(3)(E)	kW	0,88	1,01	1,27	1,00	1,22	1,54	1,85	2,19	2,83
FCCOP class	(E)		D			C			B		
Water flow	(3)	l/h	155	176	221	174	211	277	321	380	492
Water pressure drop	(3)(E)	kPa	2	3	4	5	8	11	4	6	9
Rated air flow		m ³ /h	115	135	170	135	170	225	250	310	420
Power input	(E)	W	11	13	16	9	10	14	10	12	21
Total sound power level	(4)(E)	dB(A)	30	35	40	35	40	46	37	42	49

(1) Water temperature 7°C / 12°C, air temperature dry bulb 27°C, wet bulb 19°C (47% relative humidity) according to EN1397:2021

(2) Water temperature 7°C / 12°C, air temperature dry bulb 27°C, wet bulb 19°C (47% relative humidity)

(3) Water temperature 45°C / 40°C, air temperature 20°C

(4) Sound power measured according to standards ISO 3741 and ISO 3742

(E) EUROVENT certified data

Power supply 230-1-50 (V-ph-Hz)

4 PIPES - RATED TECHNICAL DATA

FLAT S i			13			23			43		
Speed			min	med	max	min	med	max	min	med	max
Control voltage	(E)	V	4,80	5,80	7,70	4,50	5,80	7,90	5,10	6,30	8,00
Total cooling capacity	(1)(E)	kW	0,85	0,97	1,23	1,08	1,33	1,74	1,75	2,12	2,75
Sensible cooling capacity	(1)(E)	kW	0,60	0,69	0,88	0,74	0,92	1,21	1,26	1,54	2,01
FCEER class	(E)					B					
Water flow	(2)	l/h	148	168	213	186	230	300	303	368	477
Water pressure drop	(2)(E)	kPa	3	3	5	4	7	11	5	7	10
Heating capacity	(3)(E)	kW	1,04	1,15	1,36	1,35	1,56	1,91	2,16	2,45	3,02
FCCOP class	(E)		C			B			B		
Water flow	(3)	l/h	91	100	119	118	136	167	189	215	264
Water pressure drop	(3)(E)	kPa	2	2	3	4	5	7	2	2	3
Rated air flow		m ³ /h	115	135	170	135	170	225	250	310	420
Power input	(E)	W	7	8	10	7	8	11	10	12	21
Total sound power level	(4)(E)	dB(A)	30	35	40	35	40	46	37	42	49

(1) Water temperature 7°C / 12°C, air temperature dry bulb 27°C, wet bulb 19°C (47% relative humidity) according to EN1397:2021

(2) Water temperature 7°C / 12°C, air temperature dry bulb 27°C, wet bulb 19°C (47% relative humidity)

(3) Water temperature 65°C / 55°C, air temperature 20°C

(4) Sound power measured according to standards ISO 3741 and ISO 3742

(E) EUROVENT certified data

Power supply 230-1-50 (V-ph-Hz)

DIMENSIONAL DRAWINGS

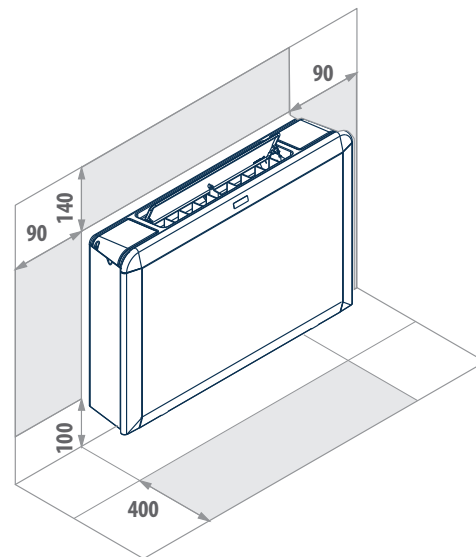
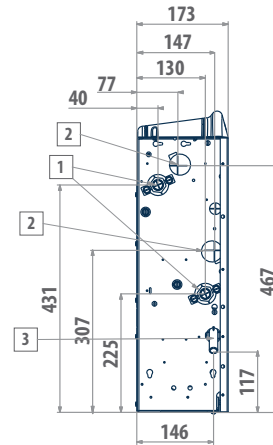
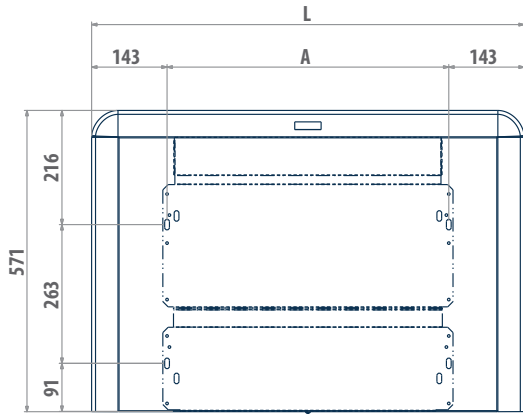
FLAT S i

LEGEND

- | | |
|---|---|
| 1 | Water connections standard heat exchanger \varnothing 1/2" |
| 2 | DF 1-row additional heat exchanger water connections \varnothing 1/2" |
| 3 | Condensate discharge diameter for vertical installation \varnothing 16 mm |
| Condensate discharge diameter for horizontal installation \varnothing 17 mm | |

FLAT S i	A mm	L mm	 kg
13	534	820	17
23	704	990	21
43	874	1160	23

Design fan coil units with centrifugal fan

FLAT 2 - 5 kW



Galletti FLAT: performance and design in a single indoor unit

FLAT Galletti has been engineered to offer performance and design features placing it at the top of its category. The uniqueness of FLAT lies both in the use of extremely high quality materials - which contribute to making this product exceptionally robust - and the assurance of constant performance over time.

FLAT optimizes the distribution of air in the room thanks to the integrated air outlet grille which makes it possible to direct the treated, filtered air in 4 directions. The main flap is equipped with a microswitch which shuts off the fan and the valves when the flap closes. The flap is useful for avoiding dust build-up in periods of non-use.

The adoption of UV-stabilized ABS in the parts making up the cabinet and antistatic ABS in the fan assembly (volute and centrifugal fan) guarantee that the product will maintain the same aesthetics and noise levels throughout its lifetime.

Particular care has been taken in the design of the fan drive assembly, which guarantees exceptionally quiet operation both in version with 3- and 6-speed motors.



2 pipes systems



4 pipes systems



Vertical installation



Centrifugal fan

PLUS

- » Cabinet with a refined design
- » Microswitch on exit air flap
- » Use of UV-stabilized ABS
- » Reversible water connections
- » 3 - 6 speed motor
- » ABS centrifugal fans



MAIN COMPONENTS

Cabinet

RAL9010 colour, front panel made of sheet steel. Side panels and an upper grille with covers on either side manufactured from UV-stabilised ABS to maintain the colour intact over time. The upper grille consists of a flap and adjustable louvers. The flap features a microswitch that automatically shuts down the unit when the flap itself is closed.



Structure

Built from galvanised steel sheet of extra thickness, heat and sound insulated by means of Class 1 self-extinguishing panels.

Heat exchanger

High efficiency heat exchanger made with copper piping and aluminium fins, provided with brass manifolds and vent valve. The water connections are reversible at the time of installation. On request it is possible to mount an additional heat exchanger for 4-pipe systems.

Fans

Double suction centrifugal fans, statically and dynamically balanced, manufactured from anti-static ABS, with blades having an airfoil section and offset modules. The fans are housed in a low-noise ABS volute with high-efficiency profile.

Electric motor

It is mounted on vibration dampers, with permanently activated capacitor and thermal protection of the windings, and is directly coupled with the fans. It is available with 3 rotation speeds to meet all specific requirements in terms of performance, noise levels, and power consumption.

Air filter

Honey-comb polypropylene washable air filter, easily removable for maintenance operations.

CONFIGURATOR

The models are completely configurable by selecting the version and the options. To the right is shown an example of configuration.

Version	Field	1	2	3	4	5	6	7	8	9	10	11
FLAT10		L	0	M	0	1	E	0	0	0	0	A

To verify the compatibility of the options, use the selection software or the price list.

CONFIGURATOR

- | | |
|---|---|
| <p>1 Version
L L - Wall mounted with cabinet</p> <p>2 Motor
0 3-speed motor
I BLDC motor
P 6 speed motor</p> <p>3 Main coil hydraulic side
L Water connections on the left side
R Water connections on the right</p> <p>4 Additional coil hydraulic side / heating element
0 Absent
L Water connections on the left side
R Water connections on the right</p> <p>5 Valve
0 Absent
1 VKS - 3 ways valve - 230 V - ON/OFF - complete hydraulic kit
2 KV - 2 ways valve - 230 V - ON/OFF
3 VKMS - 3 ways valve - 24 V - MODULATING - complete hydraulic kit
4 KVM - 2 ways valve - 24 V - MODULATING
5 VKS24 - 3 way valve - 24 V - ON/OFF - complete hydraulic kit
6 KV24 - 2 way valve - 24 V - ON/OFF
A VKSND - 3 way valve - 230 V - ON/OFF - hydraulic kit on coil side
B VKMSND - 3 ways valve - 24 V - MODULATING - hydraulic kit on coil side
C VKS24ND - 3 ways valve - 24 V - ON/OFF - hydraulic kit on coil side</p> <p>6 Control panel
0 Absent
1 CB - On-board speed selector
3 TIB - Speed selector, thermostat and S/W selecting switch
4 TED 2T - microprocessor control for 2 pipes
5 TED 4T - microprocessor control for 4 pipes</p> | <p>6 TED 10 - microprocessor control for BLDC
A MCBE - MYCOMFORT BASE
C MCLE - MYCOMFORT LARGE
E EVOBOARD - Circuit board
G EVOBOARD circuit board + NAVEL Wi-Fi module</p> <p>7 Probes
0 Absent
1 SA - Remote air probe for MYCOMFORT and EVO
2 SW - Water probe for MYCOMFORT and EVO
3 SU - Humidity probe for MYCOMFORT and EVO
4 SA+SW - Remote air and water probes for MYCOMFORT and EVO
5 SA+SU - Remote air and humidity probes for MYCOMFORT and EVO
6 SA+SU+SW - Remote air, water, humidity probes for MYCOMFORT and EVO
A TC - Thermostat for minimum water temperature
B SA - Remote air probe for TED
C SW - Water probe for TED
D SA + SW - Air and water probes for TED</p> <p>8 Accessories
0 Absent
4 BV - Auxiliary drip tray
6 GIVK - Insulating shell
B Air deionization
C Air deionization with control panel</p> <p>9 Filter
0 Standard filter air</p> <p>10 Release
0 0
A A</p> <p>11 Release
A A</p> |
|---|---|

ACCESSORIES

Electromechanical control panels		KP	Power interface for connecting in parallel up to 4 fun coil units to the one controller
CB	On-board speed switch	Additional heat exchanger for 4-pipe systems	
TA	Wall-mounted room thermostat	DF	1-row additional coil for 4 pipes system
TA2	Electromechanical room thermostat with summer/winter selection	Auxiliary water drip trays, insulating shell, condensate drainage pump	
TC	Thermostat for minimum water temperature in heating mode (42 °C)	BH	Auxiliary water drip tray for horizontal installation fan coil units
TIB	On-board speed switch, thermostat and summer/winter selecting switch	BV	Auxiliary water drip tray for vertical installation fan coil units
Electronic microprocessor control panels with display		GIVKL	Insulating shell for VKS valve, water connections on the left
DIST	MYCOMFORT controller spacer for wall mounting	GIVKR	Insulating shell for VKS valve, water connections on the right
EVO-2-TOUCH	2.8" touch screen user interface for EVO control	Base and enclosure elements	
EVOBOARD	Circuit board for EVO control	ZL	Pair of base and enclosure elements for FLAT L
EVODISP	User interface with display for EVO controller	Rear covering panels	
EYNAVEL	Device for Wi-Fi or Bluetooth communication between EVOBOARD and smartphone	PH	Rear painted panel for horizontal installation with cabinet
KBFLAE	MYCOMFORT on-board installation KIT for FLAT	PV	Rear painted panel for vertical installation with cabinet
MCBE	MYCOMFORT BASE electronic controller with display	Valves	
MCLE	Microprocessor control with display MYCOMFORT LARGE	V2VDF+STD	2-way valves, ON/OFF or MODULATING actuator, 230 V or 24 V power supply, hydraulic kit, for main and additional heat exchanger
MCSUE	Humidity sensor for MYCOMFORT LARGE and EVO	V2VSTD	2-way valve, ON/OFF or MODULATING actuator, 230 V or 24 V power supply, hydraulic kit, for main heat exchanger
MCSWE	Water sensor for MYCOMFORT and EVO controllers	V3VDF	3-way valves, ON/OFF or MODULATING actuator, 230 V or 24 V power supply, hydraulic kit, for additional heat exchanger
Electronic microprocessor control panels		V3VSTD	2-way valves, ON/OFF or MODULATING actuator, 230 V or 24 V power supply, hydraulic kit, for main heat exchanger
KB F	On-board FLAT/FLAT S installation kit suitable for TED controller	VPIC	2-way valves pressure independent, ON/OFF actuator, 230 V power supply, hydraulic kit, for main heat exchanger
TED 2T	Electronic controller for AC fan control and one ON/OFF 230 V valve		
TED 4T	Electronic controller for AC fan control and two ON/OFF 230 V valves		
TED SWA	Water temperature sensor for TED controls		
Power interface and regulating louver controllers			

2 PIPES - RATED TECHNICAL DATA

FLAT			10			20			30			40		
Speed			min	med	max	min	med	max	min	med	max	min	med	max
Total cooling capacity	(1)(E)	kW	1,19	1,34	1,77	1,38	1,71	2,22	1,44	2,01	2,66	1,67	2,29	2,87
Sensible cooling capacity	(1)(E)	kW	0,86	0,96	1,27	1,02	1,27	1,66	1,10	1,53	2,03	1,27	1,75	2,20
FCEER class	(E)		D			E			E			E		
Water flow	(2)	l/h	205	231	305	238	294	382	248	346	458	288	394	494
Water pressure drop	(2)(E)	kPa	6	7	12	6	8	13	3	5	7	4	6	10
Heating capacity	(3)(E)	kW	1,16	1,29	1,71	1,38	1,67	2,17	1,55	2,04	2,72	1,76	2,32	2,89
FCCOP class	(E)		E											
Water flow	(3)	l/h	200	222	294	238	288	374	267	351	468	303	400	498
Water pressure drop	(3)(E)	kPa	4	5	9	6	8	12	2	4	6	3	5	8
Rated air flow		m ³ /h	212	226	305	227	284	378	239	344	467	277	407	520
Power input	(E)	W	19	23	33	25	38	57	28	43	57	29	45	60
Total sound power level	(4)(E)	dB(A)	34	38	44	38	44	50	30	38	44	33	42	48

FLAT			50			60			70		
Speed			min	med	max	min	med	max	min	med	max
Total cooling capacity	(1)(E)	kW	2,05	2,56	3,26	2,21	2,92	4,08	2,53	3,30	4,38
Sensible cooling capacity	(1)(E)	kW	1,61	2,00	2,53	1,76	2,33	3,28	2,04	2,69	3,60
FCEER class	(E)		E			E			D		
Water flow	(2)	l/h	353	441	561	381	503	703	436	568	754
Water pressure drop	(2)(E)	kPa	4	5	8	3	5	8	8	13	23
Heating capacity	(3)(E)	kW	2,24	2,67	3,36	2,64	3,36	4,61	2,96	3,76	4,96
FCCOP class	(E)		E								
Water flow	(3)	l/h	386	460	579	455	579	794	510	647	854
Water pressure drop	(3)(E)	kPa	3	4	5	4	7	11	8	14	22
Rated air flow		m ³ /h	338	466	593	365	552	800	418	659	911
Power input	(E)	W	40	56	75	38	58	88	41	65	96
Total sound power level	(4)(E)	dB(A)	36	42	50	42	52	59	43	51	58

- (1) Water temperature 7°C / 12°C, air temperature dry bulb 27°C, wet bulb 19°C (47% relative humidity) according to EN1397:2021
 (2) Water temperature 7°C / 12°C, air temperature dry bulb 27°C, wet bulb 19°C (47% relative humidity)
 (3) Water temperature 45°C / 40°C, air temperature 20°C
 (4) Sound power measured according to standards ISO 3741 and ISO 3742
 (E) EUROVENT certified data
 Power supply 230-1-50 (V-ph-Hz)

4 PIPES - RATED TECHNICAL DATA

FLAT			10			20			30			40		
Speed			min	med	max	min	med	max	min	med	max	min	med	max
Total cooling capacity	(1)(E)	kW	1,23	1,39	1,76	1,32	1,64	2,04	1,39	1,95	2,51	1,61	2,22	2,70
Sensible cooling capacity	(1)(E)	kW	0,88	1,00	1,28	0,97	1,22	1,54	1,06	1,48	1,93	1,22	1,70	2,08
FCEER class	(E)		D			E			E			E		
Water flow	(2)	l/h	212	239	303	227	282	351	239	336	432	277	382	465
Water pressure drop	(2)(E)	kPa	5	6	9	5	8	12	2	4	7	3	6	9
Heating capacity	(3)(E)	kW	1,35	1,46	1,76	1,44	1,65	1,96	1,78	2,13	2,59	1,96	2,35	2,74
FCCOP class	(E)		E											
Water flow	(3)	l/h	116	126	152	124	142	169	153	183	223	169	202	236
Water pressure drop	(3)(E)	kPa	3	3	5	3	4	6	6	9	12	7	10	13
Rated air flow		m ³ /h	187	215	289	205	270	359	232	332	451	273	393	502
Power input	(E)	W	28	34	49	25	38	57	28	43	57	29	45	60
Total sound power level	(4)(E)	dB(A)	34	41	47	40	45	50	31	39	45	35	43	49

4 PIPES - RATED TECHNICAL DATA

FLAT			50			60			70		
Speed			min	med	max	min	med	max	min	med	max
Total cooling capacity	(1)(E)	kW	1,96	2,46	3,06	2,12	2,82	3,82	2,43	3,18	4,09
Sensible cooling capacity	(1)(E)	kW	1,55	1,92	2,40	1,69	2,24	3,10	1,96	2,59	3,40
FCEER class	(E)		E								
Water flow	(2)	l/h	338	424	527	365	486	658	418	548	704
Water pressure drop	(2)(E)	kPa	3	4	6	6	8	15	5	8	12
Heating capacity	(3)(E)	kW	2,55	2,87	3,36	2,70	3,15	3,91	2,98	3,46	4,16
FCCOP class	(E)		E								
Water flow	(3)	l/h	220	247	289	232	271	337	257	298	358
Water pressure drop	(3)(E)	kPa	4	6	8	5	8	10	3	3	5
Rated air flow		m ³ /h	356	447	569	390	530	768	462	631	873
Power input	(E)	W	40	56	75	38	58	88	41	65	96
Total sound power level	(4)(E)	dB(A)	36	45	50	42	48	56	43	51	58

(1) Water temperature 7°C / 12°C, air temperature dry bulb 27°C, wet bulb 19°C (47% relative humidity) according to EN1397:2021

(2) Water temperature 7°C / 12°C, air temperature dry bulb 27°C, wet bulb 19°C (47% relative humidity)

(3) Water temperature 65°C / 55°C, air temperature 20°C

(4) Sound power measured according to standards ISO 3741 and ISO 3742

(E) EUROVENT certified data

Power supply 230-1-50 (V-ph-Hz)

DIMENSIONAL DRAWINGS

FLAT L

LEGEND

1	Water connections standard heat exchanger ø 1/2"
2	DF 1-row additional heat exchanger water connections ø 1/2"
3	Condensate discharge diameter for vertical installation ø 16 mm
ø	Condensate discharge diameter for horizontal installation ø 17 mm

FLAT L	A	L	kg
	mm	mm	kg
10 - 20	534	820	19
30 - 40	704	990	23
50 - 60 - 70	874	1160	28

Design fan coil unit with centrifugal fan and EC motor

FLAT i 2 - 5 kW



EC motor



2 pipes systems



4 pipes systems



Vertical installation



Centrifugal fan

Technology and design in a single solution

The Galletti FLAT i indoor hydronic units are equipped with a permanent magnet (brushless) electric motor, controlled by an inverter, which enables continuous adjustment in the number of fan revolutions.

In addition to the important reduction in electricity consumption compared to AC motors, the use of inverter EC technology makes it possible to continually adjust the operation of the unit to the actual thermo-hygrometric load of the interior, with a clear benefit in terms of comfort and reducing noise.

Its use is particularly effective in the frequent cases of operation under partial load conditions, the situation that occurs most frequently, when the adjustment logic allows greatly reduced motor rotation speeds with exceptional reductions in electricity consumption and noise emissions.

The operation of the unit with brushless motor is managed by EVO, MYCOMFORT LARGE or TED microprocessor control panel, using an analogue output (0-10 V) which is connected to the inverter.

PLUS

- » Inverter-controlled EC motor
- » Low energy consumption
- » Modulating operation
- » ABS centrifugal fans
- » Cabinet with a refined design in UV-stabilized ABS
- » Microswitch on exit air flap
- » Reversible water connections



AVAILABLE VERSIONS



FLAT Li

Suspended wall installation, with cabinet, with vertical air flow.

MAIN COMPONENTS

Cabinet with a refined design

RAL9010 colour, front panel made of sheet steel. Side panels and an upper grille with covers on either side manufactured from UV-stabilised ABS to maintain the colour intact over time. The upper grille consists of a flap and adjustable louvers. The flap features a microswitch that automatically shuts down the unit when the flap itself is closed.



Structure

Built from galvanised steel sheet of extra thickness, heat and sound insulated by means of Class 1 self-extinguishing panels.

Heat exchanger

High efficiency heat exchanger made with copper piping and aluminium fins, provided with brass manifolds and vent valve. The water connections are reversible at the time of installation. On request it is possible to mount an additional heat exchanger for 4-pipe systems.

Fans

Double suction centrifugal fans, statically and dynamically balanced, manufactured from anti-static ABS, with blades having an airfoil section and offset modules. The fans are housed in a low-noise ABS volute with high-efficiency profile.

EC electric motor

The unit is equipped with an inverter board to control the motor, which can be used separately or installed on the motor itself. This system makes it possible to precisely set the maximum rotation speed of the motor (control signal 0-10 V) even when the maximum rotation speed must be controlled to reduce noise levels.

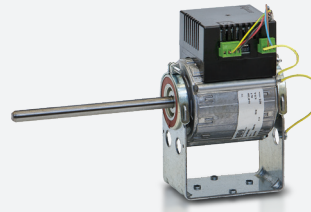

Air filter

Honey-comb polypropylene washable air filter, easily removable for maintenance operations.

ACCESSORIES

Electronic microprocessor control panels with display

DIST	MYCOMFORT controller spacer for wall mounting
EVO-2-TOUCH	2.8" touch screen user interface for EVO control
EVOBOARD	Circuit board for EVO control
EVODISP	User interface with display for EVO controller
EYNAVEL	Device for Wi-Fi or Bluetooth communication between EVOBOARD and smartphone
KBFLAE	MYCOMFORT on-board installation KIT for FLAT
MCLE	Microprocessor control with display MYCOMFORT LARGE
MCSUE	Humidity sensor for MYCOMFORT LARGE and EVO
MCSWE	Water sensor for MYCOMFORT and EVO controllers

Electronic microprocessor control panels

KB F	On-board FLAT/FLAT S installation kit suitable for TED controller
TED 10	Electronic controller for EC fan equipped with inverter and ON/OFF valves 230 V
TED SWA	Water temperature sensor for TED controls

Additional heat exchanger for 4-pipe systems

DF	1-row additional coil for 4 pipes system
-----------	--

Auxiliary water drip trays, insulating shell, condensate drainage pump

BH	Auxiliary water drip tray for horizontal installation fan coil units
-----------	--

BV	Auxiliary water drip tray for vertical installation fan coil units
-----------	--

GIVKL	Insulating shell for VKS valve, water connections on the left
--------------	---

GIVKR	Insulating shell for VKS valve, water connections on the right
--------------	--

Base and enclosure elements

ZL	Pair of base and enclosure elements for FLAT L
-----------	--

Rear covering panels

PH	Rear painted panel for horizontal installation with cabinet
-----------	---

PV	Rear painted panel for vertical installation with cabinet
-----------	---

Valves

V2VDF+STD	2-way valves, ON/OFF or MODULATING actuator, 230 V or 24 V power supply, hydraulic kit, for main and additional heat exchanger
------------------	--

V2VSTD	2-way valve, ON/OFF or MODULATING actuator, 230 V or 24 V power supply, hydraulic kit, for main heat exchanger
---------------	--

V3VDF	3-way valves, ON/OFF or MODULATING actuator, 230 V or 24 V power supply, hydraulic kit, for additional heat exchanger
--------------	---

V3VSTD	2-way valves, ON/OFF or MODULATING actuator, 230 V or 24 V power supply, hydraulic kit, for main heat exchanger
---------------	---

VPIC	2-way valves pressure independent, ON/OFF actuator, 230 V power supply, hydraulic kit, for main heat exchanger
-------------	--

2 PIPES - RATED TECHNICAL DATA

FLAT i			20			40			70		
Speed			min	med	max	min	med	max	min	med	max
Control voltage	(E)	V	5,10	6,90	8,80	4,40	6,50	8,30	4,50	6,30	8,90
Total cooling capacity	(1)(E)	kW	1,39	1,74	2,26	1,46	2,00	2,50	2,56	3,34	4,43
Sensible cooling capacity	(1)(E)	kW	1,03	1,30	1,70	1,12	1,55	1,93	2,07	2,73	3,65
FCEER class	(E)		B								
Water flow	(2)	l/h	239	300	389	251	344	430	441	575	763
Water pressure drop	(2)(E)	kPa	6	8	13	4	6	10	6	8	16
Heating capacity	(3)(E)	kW	1,52	1,84	2,39	1,76	2,32	2,89	2,96	3,76	4,96
FCCOP class	(E)		B								
Water flow	(3)	l/h	262	317	412	303	400	498	510	647	854
Water pressure drop	(3)(E)	kPa	6	8	12	3	5	8	5	9	14
Rated air flow		m ³ /h	216	284	378	283	407	520	482	659	911
Power input	(E)	W	7	11	22	9	15	31	13	21	49
Total sound power level	(4)(E)	dB(A)	38	44	53	33	42	48	43	51	58

(1) Water temperature 7°C / 12°C, air temperature dry bulb 27°C, wet bulb 19°C (47% relative humidity) according to EN1397:2021

(2) Water temperature 7°C / 12°C, air temperature dry bulb 27°C, wet bulb 19°C (47% relative humidity)

(3) Water temperature 45°C / 40°C, air temperature 20°C

(4) Sound power measured according to standards ISO 3741 and ISO 3742

(E) EUROVENT certified data

Power supply 230-1-50 (V-ph-Hz)

4 PIPES - RATED TECHNICAL DATA

FLAT i			20			40			70		
Speed			min	med	max	min	med	max	min	med	max
Control voltage	(E)	V	5,10	6,90	8,80	4,40	6,50	8,30	4,50	6,30	8,90
Total cooling capacity	(1)(E)	kW	1,21	1,51	1,88	1,63	2,25	2,74	2,46	3,22	4,14
Sensible cooling capacity	(1)(E)	kW	0,92	1,16	1,47	1,24	1,73	2,12	1,99	2,63	3,45
FCEER class	(E)		C			A			B		
Water flow	(2)	l/h	210	262	329	282	389	475	425	558	721
Water pressure drop	(2)(E)	kPa	5	8	12	3	6	9	4	6	9
Heating capacity	(3)(E)	kW	1,44	1,65	1,96	1,96	2,35	2,74	2,98	3,46	4,16
FCCOP class	(E)		B			B			B		
Water flow	(3)	l/h	124	142	169	169	202	236	257	298	358
Water pressure drop	(3)(E)	kPa	3	4	6	7	10	13	11	11	19
Rated air flow		m ³ /h	205	270	359	273	393	502	462	631	873
Power input	(E)	W	10	16	31	7	12	24	13	21	49
Total sound power level	(4)(E)	dB(A)	40	45	50	35	43	49	43	51	58

(1) Water temperature 7°C / 12°C, air temperature dry bulb 27°C, wet bulb 19°C (47% relative humidity) according to EN1397:2021

(2) Water temperature 7°C / 12°C, air temperature dry bulb 27°C, wet bulb 19°C (47% relative humidity)

(3) Water temperature 65°C / 55°C, air temperature 20°C

(4) Sound power measured according to standards ISO 3741 and ISO 3742

(E) EUROVENT certified data

Power supply 230-1-50 (V-ph-Hz)

DIMENSIONAL DRAWINGS

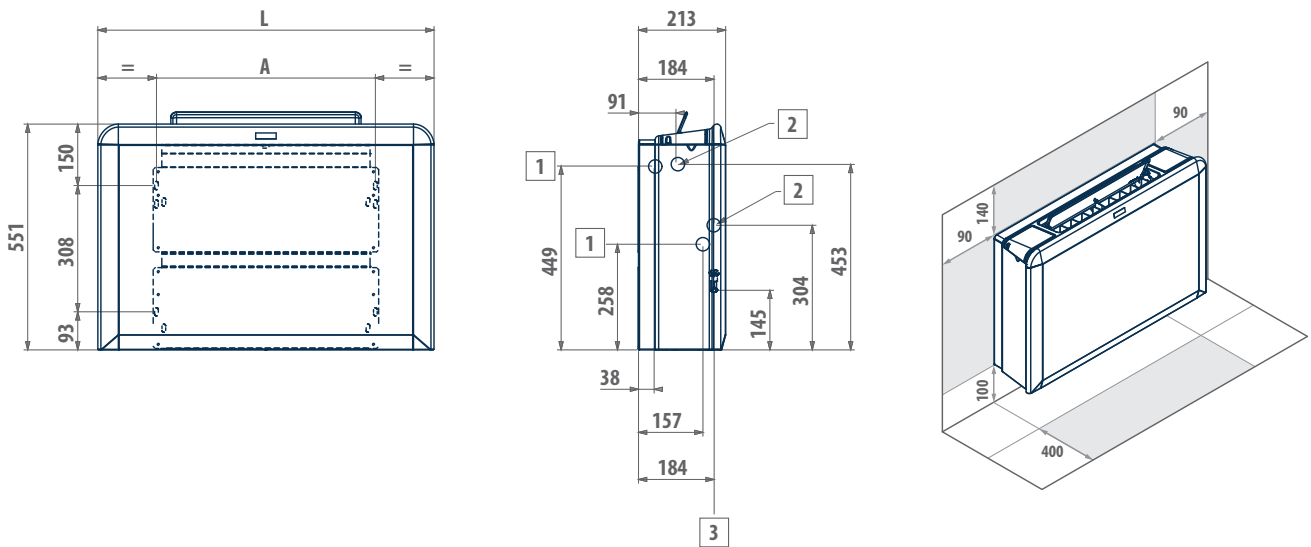
FLAT Li

LEGEND

- | | |
|---------------------------------|---|
| 1 | Water connections standard heat exchanger \varnothing 1/2" |
| 2 | DF 1-row additional heat exchanger water connections \varnothing 1/2" |
| 3 | Condensate discharge diameter for vertical installation \varnothing 16 mm |
| \varnothing | Condensate discharge diameter for horizontal installation \varnothing 17 mm |

FLAT Li	A mm	L mm	 kg
20	534	820	19
40	704	990	23
70	874	1160	28

Recess-mounted fan coil with formwork

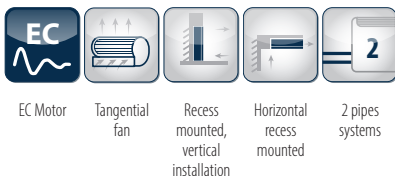
CFV 1 - 4 kW



INVISIBLE AIR CONDITIONING FOR EXTRAORDINARY COMFORT

CFV is the perfect solution to meet the design requirement of completely concealing the indoor unit. The heart of this product is the CF fan coil, which is suitable for any type of installation with a depth of only 12.6 cm. Its compact dimensions are combined with low energy consumption thanks to the EC inverter motor which, in comparison to a conventional AC motor, guarantees energy savings of up to 70 % during its seasonal operation. The fan coil is housed in the galvanised steel CYC casing for both vertical and horizontal installation. Pre-cuts are provided in the metal structure at the hydraulic and electrical connections of the unit for ease of installation. The CYP front cover panel conceals the fan coil but at the same time provides easy access for all maintenance operations. Integration with the wall is maximised by the possibility of painting the front panel, which makes it literally disappear into the room to be air-conditioned.

PLUS

- » Inverter-controlled EC motor
- » Low energy consumption
- » Modulating operation
- » Easy accessibility to the fan coil
- » Paintable front panel



VERSIONS

CFV VERTICAL INSTALLATION

1. CYPV frontal panel
2. CF Fan coil
3. Formwork CYC

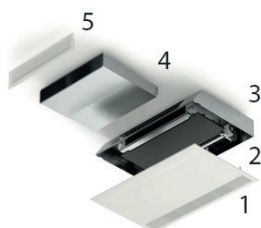
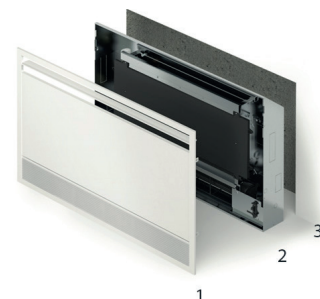

CFV HORIZONTAL INSTALLATION

1. CYPH frontal panel
2. CF Fan coil
3. Formwork CYC
4. CYRMCD telescopic duct
5. Air outlet grille with straight profile CY8048

SETTINGS

CONFIGURATOR

The models are completely configurable by selecting the version and the options. To the right is shown an example of configuration.

Version	Field	1	2	3	4	5	6	7	8	9	10	11
CF10		C	I	L	0	1	7	0	0	0	0	A

To verify the compatibility of the options, use the selection software or the price list.

CONFIGURATOR

- | | |
|---|--|
| <p>1 Version
C Recessed</p> <p>2 Motor
I Inverter motor</p> <p>3 Main coil hydraulic side
L Left
R Right</p> <p>4 Additional coil hydraulic side / heating element
0 Absent</p> <p>5 Valve
1 3-way - on/off 230V
2 2-way - on/off 230V</p> | <p>6 Control panel
7 Circuit board on the unit for connection to MYCOMFORT LARGE</p> <p>7 Probes
0 Absent</p> <p>8 Accessories
0 Absent</p> <p>9 Filter
0 Standard air filter</p> <p>10 Release
0 0
A A</p> |
|---|--|

ACCESSORIES

Electronic microprocessor control panels with display		Plenum, air intake modules, air inlet and outlet connectors and cabinets	
CYBOARD	On-board electronic circuit board for MYCOMFORT connection	RM C90	90° curve air supply duct
DIST	MYCOMFORT controller spacer for wall mounting	RM CD	Telescopic air supply duct
MCLE	Microprocessor control with display MYCOMFORT LARGE	Accessories	
MCSWE	Water sensor for MYCOMFORT and EVO controllers	C*0A00	Galvanised sheet steel casing for 2-pipe version
Air inlet and outlet grilles		P*0AH0	Ceiling-mounted cover panel with frame and intake grille for 2-pipe version
8048	Aluminium air outlet grille with 2-row fins	P*0AV0	Wall-mounted cover panel with frame, intake grille, and outlet louver for 2-pipe version
Valves		T	Motor connection cable for moving hydraulic connections from left to right on site
KVK	2-way valve with thermo-electric actuator		

2 PIPES - RATED TECHNICAL DATA

CFV	10			20			30			40			50			
		min	med	max	min	med	max	min	med	max	min	med	max	min	med	max
Speed																
Control voltage	(E) V	3,30	6,80	10,0	3,30	6,80	10,0	3,30	6,80	10,0	3,30	6,80	10,0	3,30	6,80	10,0
Total cooling capacity	(1)(E) kW	0,43	0,73	0,91	0,75	1,36	2,12	1,15	2,08	2,81	1,32	2,39	3,30	1,36	2,57	3,71
Sensible cooling capacity	(1)(E) kW	0,29	0,51	0,71	0,59	1,04	1,54	0,83	1,51	2,11	1,02	1,84	2,65	1,05	1,98	2,90
FCEER class	(E)	C			B			A			A			A		
Water flow	(2) l/h	74	126	157	129	234	365	198	358	484	227	412	568	234	443	639
Water pressure drop	(2)(E) kPa	6	10	12	2	4	8	3	10	17	3	9	18	3	11	21
Heating capacity	(3)(E) kW	0,37	0,69	1,02	0,82	1,53	2,21	1,20	2,16	3,02	1,47	2,59	3,81	1,49	2,82	4,32
FCCOP class	(E)	D			B			B			B			B		
Water flow	(3) l/h	64	119	176	141	263	381	207	372	520	253	446	656	257	486	744
Water pressure drop	(3)(E) kPa	3	7	9	2	4	9	3	9	19	3	9	21	3	7	23
Rated air flow	m ³ /h	49	90	146	118	210	294	180	318	438	247	410	567	262	479	663
Power input	(E) W	5	7	11	4	8	19	6	11	20	5	11	29	6	12	33
Total sound power level	(4)(E) dB(A)	37	47	54	37	47	54	37	47	54	37	47	55	37	48	57

(1) Water temperature 7°C/12°C, air temperature dry bulb 27°C, wet bulb 19°C (47% relative humidity) according to EN1397:2021

(2) Water temperature 7°C / 12°C, air temperature dry bulb 27°C, wet bulb 19°C (47% relative humidity)

(3) Water temperature 45°C / 40°C, air temperature 20°C

(4) Sound power measured according to standards ISO 3741 and ISO 3742

(E) EUROVENT certified data

Power supply 230-1-50 (V-ph-Hz)

Hydronic indoor units CFV

DIMENSIONAL DRAWINGS

CYC

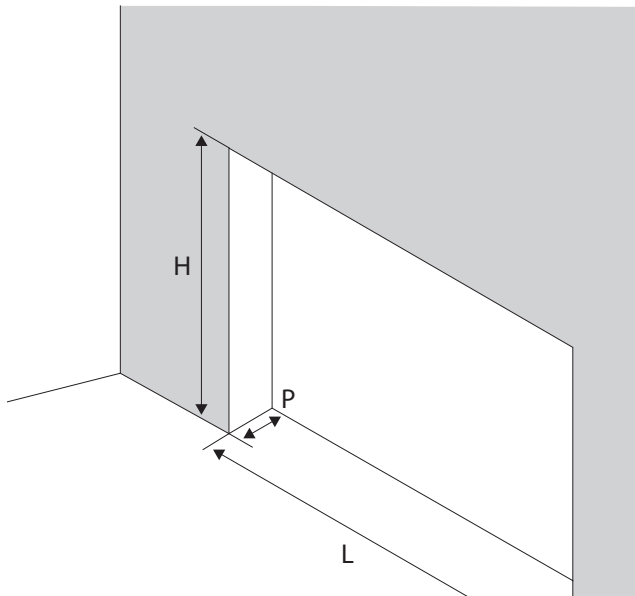

CYP

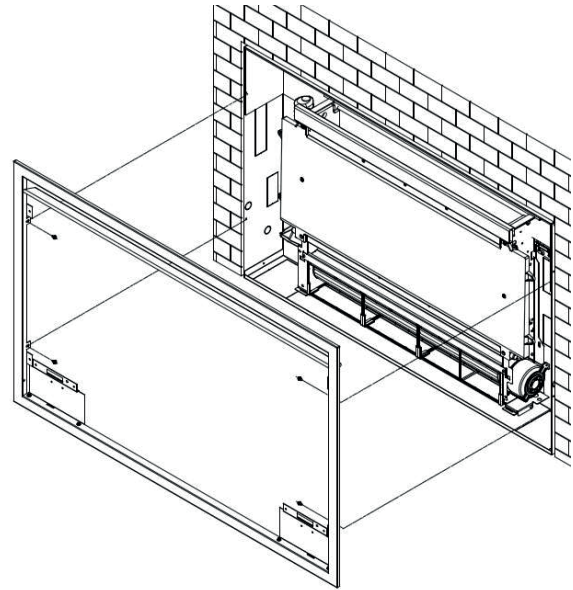

Mod.	L mm	H mm	P mm
CF10CI	740	730	142
CF20CI	940	730	142
CF30CI	1140	730	142
CF40CI	1340	730	142
CF50CI	1540	730	142

CF 2 pipes

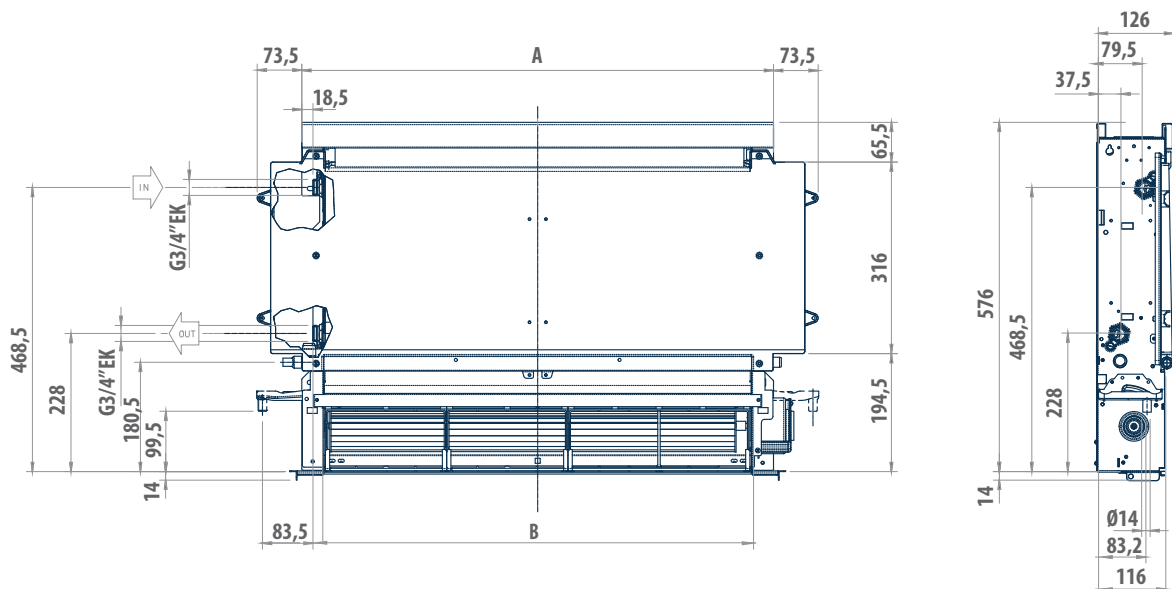

Mod.	A mm	B mm
CF10CI	378	305
CF20CI	578	505
CF30CI	778	705
CF40CI	978	905
CF50CI	1178	1105

High wall-mounted fan coil units

GHW 2 - 4 kW



Where space is precious, comfort comes from above.

In recent years, energy saving has become a top priority. GHW meets this need thanks to the EC motor with inverter technology, which ensures high efficiency, the hourly programming function, which allows operation to be adapted to actual needs, and the eco mode, designed to offer optimal comfort while minimizing consumption. Installing a high-wall fan coil is an intelligent solution to optimize space in modern environments, where every square meter counts. This type of installation not only frees up floor space for furniture or other uses but also allows for more even air distribution, improving living comfort.

The infrared remote control makes comfort control extremely convenient, allowing you to adjust temperature, ventilation speed, and operating modes comfortably from the sofa. GHW can be integrated into a supervision system via the Modbus communication protocol.

Designed to offer maximum versatility and ease of installation. It is available with a three-way valve already installed, allowing to optimize installation time and minimize the installer's work. Alternatively, it can be configured with a two-way valve, particularly useful when a modulating circulator or other flow control devices are present, providing a fully customizable solution based on the specific system requirements.

PLUS

- » Electronically controlled EC motor
- » Compact dimensions, identical for the whole range
- » Incorporated 3- way or 2-way ON/OFF valves
- » Self-diagnosis system with error code display on the screen.
- » Construction of global addressable networks with an external supervisor



GHW13/23/33 configuration

Refers to units equipped with a three-way valve with ON/OFF actuator, already installed on board.

GHW12/22/32 configuration

Refers to units equipped with a two-way valve with ON/OFF actuator, already installed on board.

MAIN COMPONENTS

Cabinet

Characterized by an elegant and versatile design, it is crafted from durable ABS to seamlessly blend into any environment. The air outlet is equipped with a vertical deflector featuring adjustable fins to ensure uniform air distribution throughout the room. The front panel includes an integrated display showing the ambient temperature and any malfunction notifications.



Heat exchanger

The finned block heat exchangers consist of copper tubing and aluminium fins. Thanks to the hydrophilic treatment, the wettability of the aluminum fins is improved, ensuring rapid removal of condensation from the fan coil and preventing the formation of mold and bacteria.

Hydraulic connections

Viewing the unit from the front, the hydraulic connections (already insulated) emerge from the left side of the unit and must therefore be connected to the system on the right side. Meanwhile, the condensate drain pipe provided on the right side of the unit must be secured on the left side. The unit's mounting template is specifically designed with a strategic hole intended to facilitate the hydraulic connections

EC motor and fan

The electronic motor with permanent magnets is designed to modulate the ventilation speed, reducing electricity consumption to less than half compared to asynchronous motors. The motor acts on the rotation of a low-noise tangential fan.

Valve assembly

3-way or 2-way ON/OFF valves already wired and installed inside the indoor unit. The connection to the system is made with hoses located on the rear of the unit. The valve diverts part of the unused water flow from the fan coil to a bypass circuit, ensuring the stability of the flow in the main system.



Remote control

Included by default, the infrared remote control allows you to control all the fan coil functions, including setting the on/off timer.



WALLPAD

The GHWWP wallpad manages all the functions of the infrared remote control but is also equipped with a large LCD display that makes the user experience more intuitive.



RATED TECHNICAL DATA

GHW			1			2			3		
Speed			min	med	max	min	med	max	min	med	max
Total cooling capacity	(1)(E)	kW	1,80	2,04	2,30	2,19	2,54	2,91	2,88	3,30	3,81
Sensible cooling capacity	(1)(E)	kW	1,38	1,55	1,74	1,71	2,00	2,33	2,31	2,71	3,18
FCEER class			A			D			B		
Water flow	(1)	l/h	360	400	460	380	450	510	510	570	670
Water pressure drop	(1)(E)	kPa	18	22	29	23	30	37	33	41	57
Heating capacity	(2)(E)	kW	1,70	2,00	2,73	2,42	2,77	3,23	3,09	3,65	4,30
FCCOP class			B			D			B		
Water flow	(2)	l/h	380	450	490	420	490	560	560	640	730
Water pressure drop	(2)(E)	kPa	18	22	29	23	30	37	33	41	57
Rated air flow		m ³ /h	356	412	462	331	339	484	590	698	825
Power input	(E)	W	9	10	11	29	32	35	15	20	34
Total sound power level	(3)(E)	dB(A)	39	40	42	35	42	48	47	51	57

(1) Water temperature 7°C/12°C, air temperature dry bulb 27°C, wet bulb 19°C (47% relative humidity) according to EN1397:2021

(2) Water temperature 45°C / 40°C, air temperature 20°C

(3) Sound power measured according to standards ISO 3741 and ISO 3742

(E) EUROVENT certified data

Power supply 230-1-50 (V-ph-Hz)



DIMENSIONAL DRAWINGS

GHW

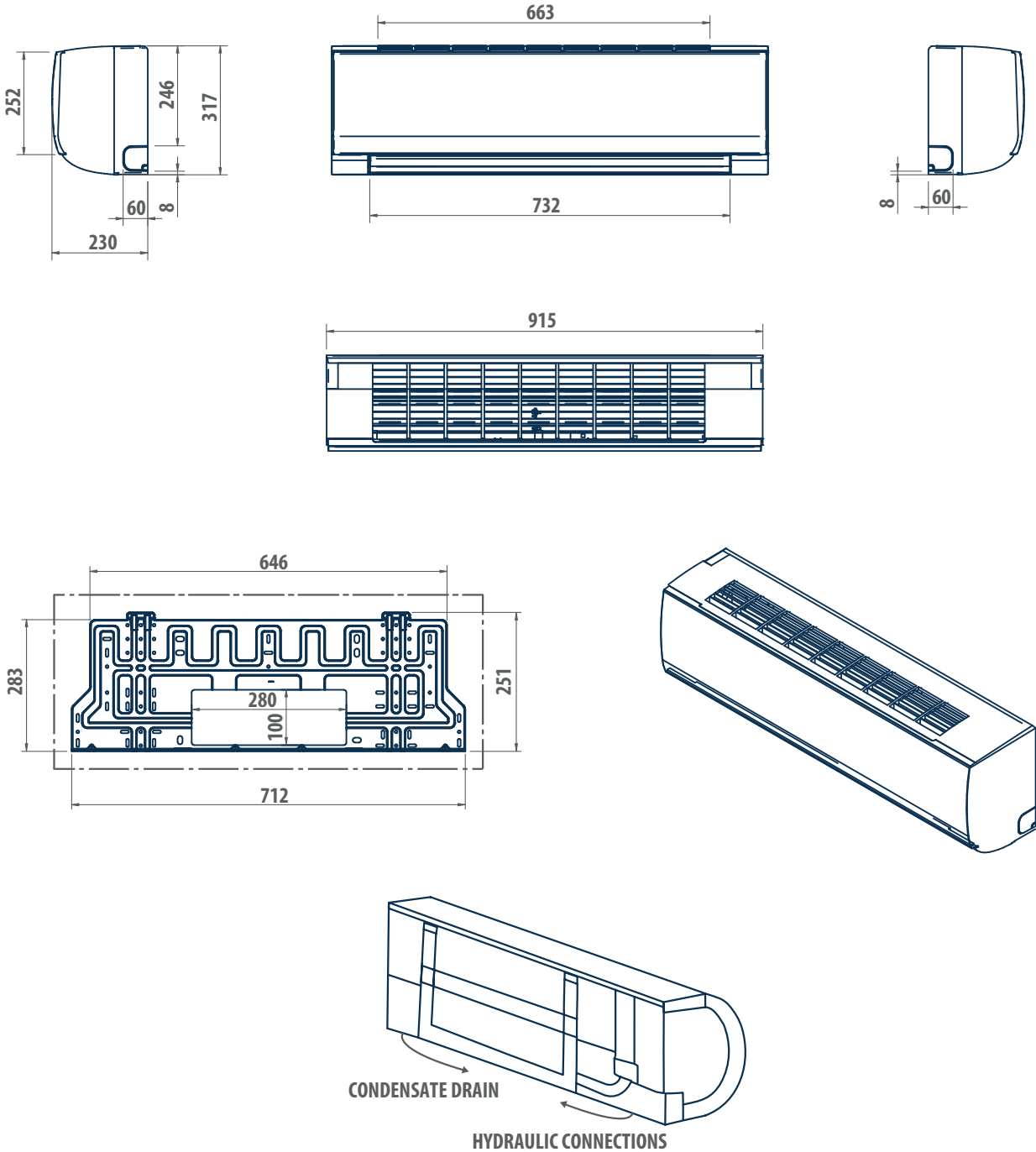

GHW		1	2	3
Water connections	"		1/2	
Condensate discharge	mm		16	
Weight	kg	13	13	13

Design module with the Coandă effect



EFFETTO



Comfort and design in perfect harmony

Galletti introduces EFFETTO, the design module for air intake and diffusion designed to complement the reliability and comfort of ACQVARIA and ACQVARIA i hydronic cassette units (600x600 mm model).

EFFETTO breaks with standard hydronic cassette units, going far beyond the classic ABS grille with adjustable fins, and presents a design module that takes advantage of the Coandă effect.

Galletti's Advanced Design Unit has created an Italian-made hydronic cassette unit with a minimalist, streamlined design that can be incorporated into the style of any space, even in terms of colour.

EFFETTO is not just about aesthetics but also comfort, as it has been designed to optimise air diffusion thanks to the Coandă effect.

EFFETTO's Dibond metal panel is comprised of a sandwich of aluminium and polyethylene.

The fine metallic finish is combined with the insulating properties of polyethylene to prevent condensation. The steel intake grille creates a single surface with the panel, thus enhancing the overall subtlety of the product. The filter can be easily removed for maintenance operations. The air duct is made of black RAL 9005 polystyrene for a perfect colour match, and its geometry is designed to optimise the air flow in the room.

The brightness of the aluminium allows the grille to adapt to any situation, while keeping the milled edge of the panel, which outlines its shape, clearly visible, even in low light conditions. The module, detached from the ceiling, interacts with all the elements and light sources in the room.

EFFETTO is the perfect choice to ensure a smooth, streamlined appearance to the space to be air-conditioned.

AVAILABLE VERSIONS

Three colour versions are available: brushed natural aluminium, white RAL 9010, and black RAL 9005. Black is also used for all the components of the internal and technological structure in order to create a shadow effect on the surrounding surfaces, making the panel appear to float in the air.

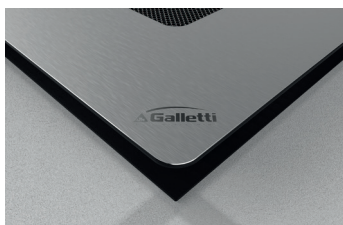

Grey - natural brushed aluminium



White - RAL 9010



Black - black RAL 9005

COMPUTATIONAL FLUID DYNAMICS SIMULATIONS

AIR DUCT

Computational fluid dynamics (CFD) simulations have made it possible to study the diffusion of air in interiors in order to make the most of the Coandă effect: the air flow reaches the ceiling without passing directly over the occupant, thus preventing localised discomfort. Cross-section of the EFFETTO module with air flows highlighted.

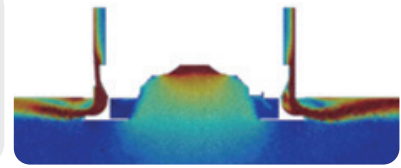

HEATING CASE STUDY

In CFD simulations we evaluated a space used as a restaurant that can accommodate about 100 people equipped with 9 ACQVARIA hydronic cassette units with EFFETTO module. The design summer conditions are: outdoor air temperature 5 °C, room setpoint temperature 20 °C. Standard UNI EN ISO 7730 identifies indices that define situations of temperature and humidity discomfort: Floor temperature; Highly uneven vertical temperatures; Draughts; Predicted Mean Vote.

AIR TEMPERATURE FIELD

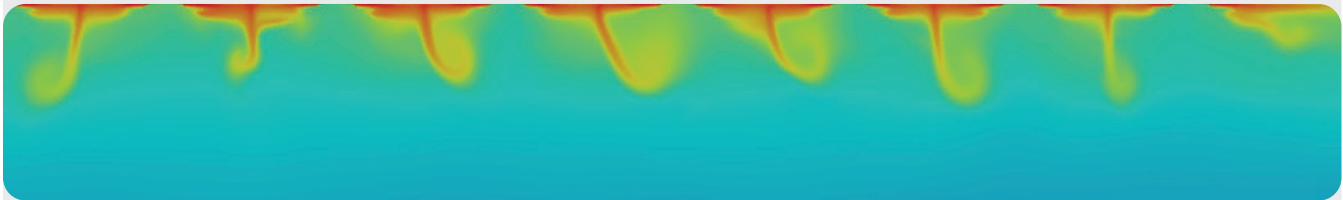

AIR SPEED FIELD

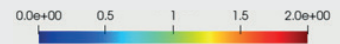

COOLING MODE CASE STUDY

In CFD simulations we evaluated a space used as a restaurant that can accommodate about 100 people equipped with 9 ACQVARIA hydronic cassette units with EFFETTO module. The design summer conditions are: outdoor air temperature 33 °C, room setpoint temperature 26 °C. The geometry of the black polystyrene conveyors was designed with the help of CFD simulations and experimental verifications at the R&D laboratories Galletti. The aim was to ensure that the air jet touches the ceiling and walls without ever directly hitting the occupant through the Coandă effect. The air distribution in the room is homogeneous, the left zone has a higher than average air temperature because it is adjacent to the kitchen.

AIR TEMPERATURE FIELD



AIR SPEED FIELD

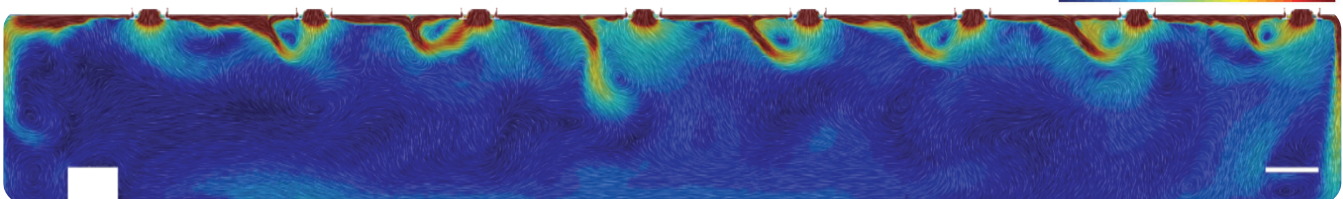
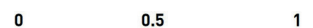

CONCLUSIONS

All the comfort indices taken into consideration confirmed that the temperature and humidity comfort conditions are guaranteed even in the presence of air stratification in the areas near the ceiling, which is a common occurrence during the heating season.

Design module with the Coandă effect - EFFETTO

EFFETTO *AirClissi*

EFFETTO AIRCLISSI



Often hydronic indoor units are evaluated on the basis of a single criterion: their technical performance. Undoubtedly, thermodynamic and acoustic performance are very important, but only if they are part of a broader comprehensive concept. Today, the hydronic indoor unit must be considered equally with all the other furnishings in the space to be air-conditioned: a platform capable of interacting with the layout of the environment and the people who live in it. This interaction is now even stronger, with a novel emotional dimension for hydronic cassette units: light.

EFFETTO has now been combined with AirClissi to become the first Coandă effect illuminated module in the field of hydronic cassette units: air and light come together to create a unique design. EFFETTO AirClissi is a new Galletti product that takes the concept of the hydronic cassette unit to an unprecedented aesthetic level, where light is the new star of the show.

AVAILABLE VERSIONS

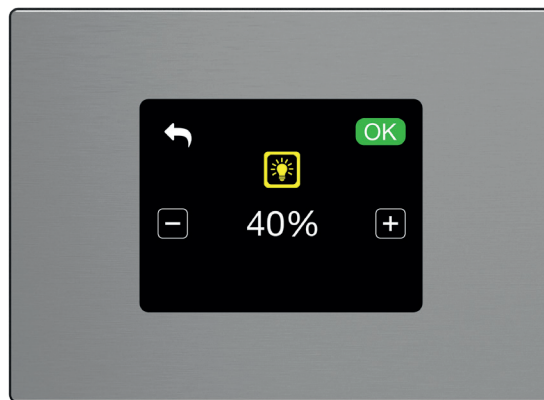
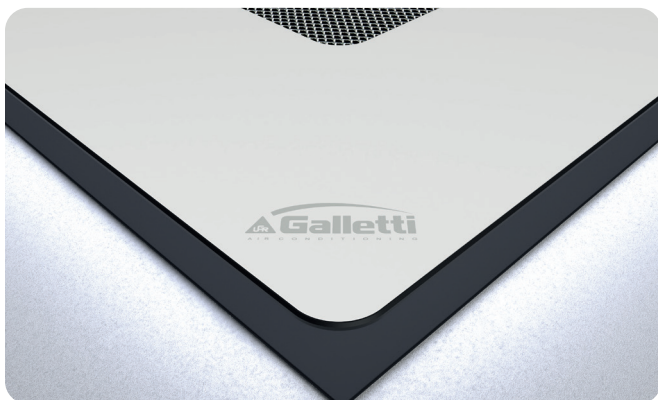

AirClissi illuminated module is available in neutral 4000 K light. This chromatic version is compatible with Grey, White, and Black EFFETTO.

The light intensity can be regulated by means of the EVO microprocessor controller. A single device gives you full control over the temperature and humidity conditions of the space and now also over its lighting. Its extreme elegance is achieved through combining minimal lines and character, the Dibond material, and light.

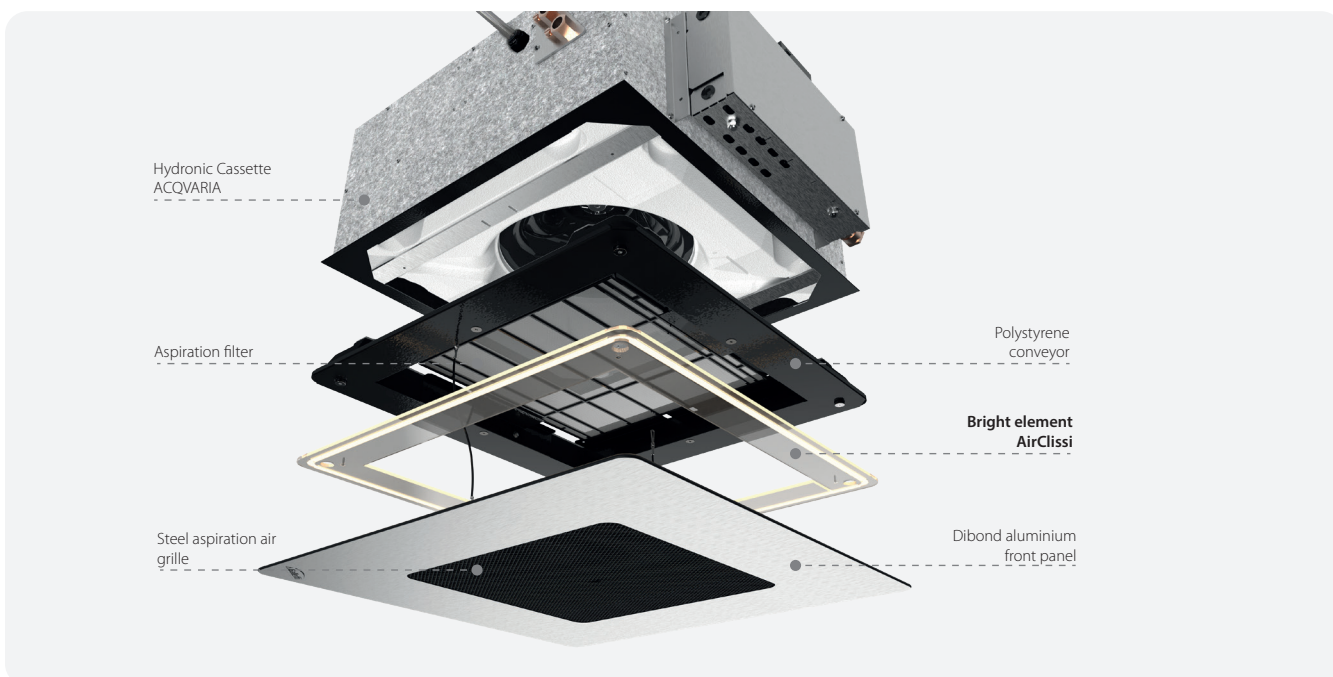

DIMENSIONAL DRAWINGS

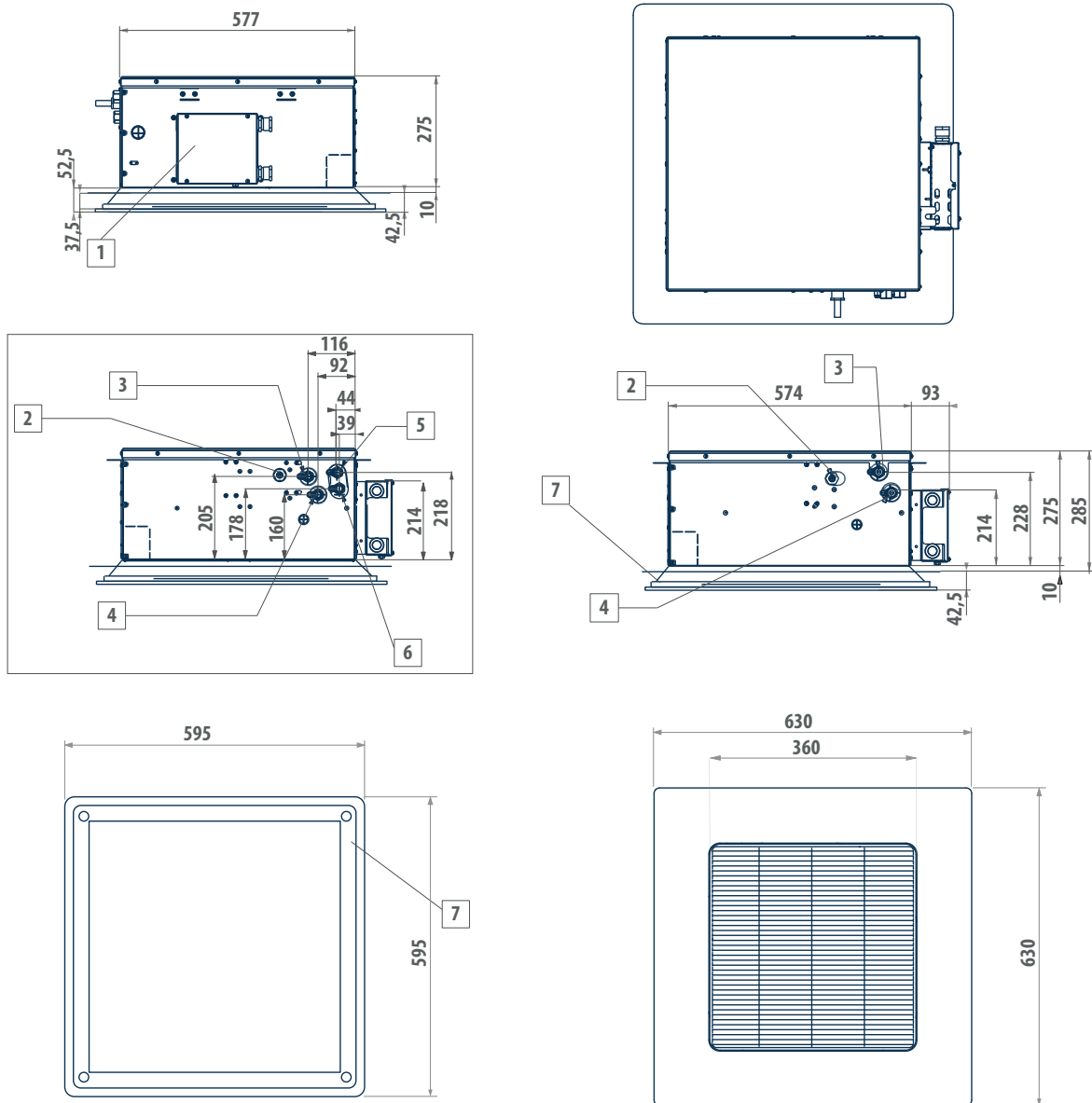
ACQVARIA 10-20-30-35 + EFFETTO + AirClissi

ACQVARIA	kg
AQ10Q0B0 - AQ10Q1B0 - AQ10Q0BB - AQ10Q1BB	23 + 2,5
AQ20Q0B0 - AQ20Q1B0 - AQ20Q0BB - AQ30Q0B0 - AQ30Q1B0 - AQ30Q0BB - AQ30Q1BB	24 + 2,5

LEGEND	
1	Electric box
2	Condensate discharge \varnothing 10
3	Water outlet \varnothing 1/2" female gas
4	Water inlet \varnothing 1/2" female gas
5	Water outlet \varnothing 1/2" DF female gas
6	Water inlet \varnothing 1/2" DF female gas
7	AirClissi panel (optional)

Design module with the Coandă effect EFFETTO

Cassette fan coils

ACQVARIA 3 - 10 kW



PLUS

- » Reliability and sturdiness in a compact design
- » Fresh air with direct or mixed introduction
- » Heat exchanger up to 3 rows
- » Condensate drainage pump for height differences of up to 0.9 m
- » Reduced installation and commissioning time

AVAILABLE VERSIONS

In addition to the 2 ABS grilles with adjustable fins it is available EFFETTO and EFFETTO AirClissi.

EFFETTO, module for intake and diffusion air with the Coandă effect

EFFETTO Airclissi, new design concept which integrates light with the Coandă effect air diffusion.



Grey - natural brushed aluminium

White - RAL 9010
EFFETTO

Black - black RAL 9005



White RAL9003

STANDARD

White RAL9010

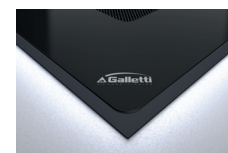

Neutral light
EFFETTO + AirClissi

Solidity and efficiency in a single product.

The range of hydronic cassette units ACQVARIA, with 3 speed motor, consists of six models for 2-pipe systems and six models for 4-pipe systems.

Designed in two dimensional frames (600x600 mm and 900x900 mm modularity), it is characterised by high performance and extremely low noise levels, as a result of the special care taken in the design of the heat exchangers and fan assemblies.

The suspended ceiling unit houses all the components, heat exchange coil, fan drive assembly, and condensate collection and drainage system. Its structure is designed for introducing fresh air into the space, mixing it with re-covered air, and distributing the treated air from the cassette unit to adjacent rooms.

The condensate drainage pump, suitable for height differences of up to 90 cm, is controlled by a float switch with 3 activation levels for exceptionally low noise and safe operation.

The design and colour, RAL9003 or RAL9010, of the air intake and diffusion louvre guarantee optimal integration into the suspended ceiling panels. Easy access to the air filter for cleaning operations.

ACQVARIA cassette units can be combined with all wall-mounted, electronic, or microprocessor-programmable control panels with user interface.

On request, the EVO BOARD regulator; air, water, and humidity probes; and 2- or 3-way valves with ON-OFF or modulating actuator can be installed on the unit.

Are also available pressure-independent balancing and control valves, the use of which significantly reduces commissioning time.

MAIN COMPONENTS

Structure

Made of galvanised steel sheet with internal polyurethane foam coating and external flocked PES to guarantee heat and sound insulation. Fresh air can be introduced into the room directly through the unit due to the provision of connections for neutral or mixed introduction. Accessories are available for connection to ducts. There are systems on the unit for anchoring it to the ceiling. The electrical wiring is housed in a containment box and is easily accessible from the side for easy connection

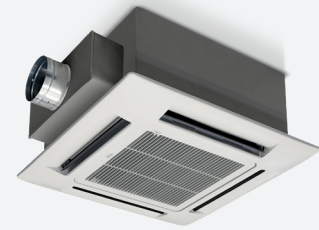

Heat exchanger

Copper pipe and high efficiency aluminium fins secured to the pipe by mechanical expansion. With at least two rows in the models for 2-pipe systems, it is available in the 2+1 configuration in the models for 4-pipe systems. The coil comes complete with manual air vent valves. On request, valves can be connected to the coil to regulate and balance the operation of the unit.

Fan drive assembly

Three-speed electrical motor, directly connected to a centrifugal fan with backward-curving blades with profile optimised for stable operation at all speeds.

Air filter

Honey-comb polypropylene washable air filter, easily removable for maintenance operations.

Condensate collection and drainage system

Located under the heat exchanger, the main drip tray is made of polystyrene and is inserted inside the profiles optimised for the distribution of air in the space. The condensate drainage pump is able to raise the condensate up to 0.9 m from the exit point from the unit. The operation of the pump is controlled by a float switch with three levels of action that activate it, stop it and, if the critical level is exceeded, stop the operation of the cassette unit fan and close the water valve. The supply is completed by the auxiliary water drip tray for the collection of condensate from the regulating valves.

Louvre

It is square shaped for the intake and diffusion of air in the space, and it is made of ABS, colour RAL9003 or RAL9010. The air intake louvre can be opened for access to the air filter. Air is diffused in the space through the 4 sides, each of which is equipped with an adjustable fin with suitable thermal insulation.

Also available from today the new aluminium design module EFFETTO for intake and diffusion air with the Coandă effect.



Control mode

Galletti renews the fan coil control modes by integrating, on the EVO platform, the new EVO-2-TOUCH user interface and the NAVEL device for management with a smartphone.



EVO-2-TOUCH

is a user-friendly user interface with a 2.8" capacitive display with built-in temperature and humidity probes.

NAVEL

is the device paired with EVOBOARD that makes possible Wi-Fi or Bluetooth communication with a smartphone containing GALLETTI APP (available for iOS and Android).

ACCESSORIES

Electronic microprocessor control panels with display

DIST	MYCOMFORT controller spacer for wall mounting
EVO-2-TOUCH	2.8" touch screen user interface for EVO control
EVOBOARD	Circuit board for EVO control
EVODISP	User interface with display for EVO controller
EYNAVEL	Device for Wi-Fi or Bluetooth communication between EVOBOARD and smartphone
MCBE	MYCOMFORT BASE electronic controller with display
MCLE	Microprocessor control with display MYCOMFORT LARGE
MCSUE	Humidity sensor for MYCOMFORT LARGE and EVO
MCSWE	Water sensor for MYCOMFORT and EVO controllers
Electronic microprocessor control panels	
TED 2T	Electronic controller for AC fan control and one ON/OFF 230 V valve
TED 4T	Electronic controller for AC fan control and two ON/OFF 230 V valves

TED SWA	Water temperature sensor for TED controls
Power interface and regulating louvre controllers	
KP	Power interface for connecting in parallel up to 4 fun coil units to the one controller
Valves	
PIC-AQ	PRESSURE-INDEPENDENT 2-way valves
V2-AQ	2-way valve, ON/OFF or MODULATING actuator, 230 V or 24 V power supply, hydraulic kit, for model with 1 or 2 heat exchangers
V3-AQ	3-way valve, ON/OFF or MODULATING actuator, 230 V or 24 V power supply, hydraulic kit, for model with 1 or 2 heat exchangers
Plenum, air intake modules, air inlet and outlet connectors and cabinets	
BAR	Spigot for introduction of mixed renewal air
MOB	Cabinet for cassette
PAR	Plenum for introduction of unmixed renewal air
PMAA	Air outlet plenum

Cassette unit ACQVARIA

RATED TECHNICAL DATA 2 PIPES

ACQVARIA			AQ10Q0B0			AQ20Q0B0			AQ30Q0B0		
Speed			min	med	max	min	med	max	min	med	max
Total cooling capacity	(1)(E)	kW	1,70	1,97	2,53	2,39	3,55	4,31	3,40	4,61	5,00
Sensible cooling capacity	(1)(E)	kW	1,33	1,60	2,14	1,78	2,53	3,18	2,43	3,44	3,79
FCEER class	(E)		D			C			D		
Water flow	(1)	l/h	295	342	441	416	616	749	593	803	873
Water pressure drop	(1)(E)	kPa	5	6	9	9	19	26	9	16	18
Heating capacity	(2)(E)	kW	1,97	2,33	3,10	2,29	3,44	4,30	3,49	4,92	5,35
FCCOP class	(E)		D			D			E		
Water flow	(2)	l/h	342	404	539	399	597	747	607	855	930
Water pressure drop	(2)(E)	kPa	4	7	11	7	15	22	8	15	17
Rated air flow		m ³ /h	297	379	557	306	487	640	479	717	805
Power input	(E)	W	25	32	58	32	40	50	57	74	89
Total sound power level	(3)(E)	dB(A)	33	37	45	39	43	50	47	55	58

ACQVARIA			AQ40Q0B0			AQ50Q0B0			AQ60Q0B0		
Speed			min	med	max	min	med	max	min	med	max
Total cooling capacity	(1)(E)	kW	4,64	5,36	7,01	5,16	6,11	8,24	6,34	8,61	9,73
Sensible cooling capacity	(1)(E)	kW	3,42	3,99	5,29	3,68	4,37	6,10	4,59	6,40	7,35
FCEER class	(E)					C					
Water flow	(1)	l/h	805	930	1223	893	1060	1434	1097	1498	1696
Water pressure drop	(1)(E)	kPa	14	18	28	12	16	26	27	43	53
Heating capacity	(2)(E)	kW	5,16	6,06	8,17	5,22	6,53	9,18	6,71	9,53	11,1
FCCOP class	(E)		D			C			D		
Water flow	(2)	l/h	897	1053	1420	908	1136	1596	1167	1656	1930
Water pressure drop	(2)(E)	kPa	14	18	30	10	15	26	27	46	58
Rated air flow		m ³ /h	801	997	1494	718	902	1380	902	1380	1651
Power input	(E)	W	47	64	108	47	64	108	64	108	147
Total sound power level	(3)(E)	dB(A)	35	40	51	35	40	51	40	51	56

(1) Water temperature 7°C/12°C, air temperature dry bulb 27°C, wet bulb 19°C (47% relative humidity) according to EN1397:2021

(2) Water temperature 45°C / 40°C, air temperature 20°C

(3) Sound power measured according to standards ISO 3741 and ISO 3742

(E) EUROVENT certified data

Power supply 230-1-50 (V-ph-Hz)

RATED TECHNICAL DATA 4 PIPES

ACQVARIA			AQ10Q0BB			AQ20Q0BB			AQ30Q0BB		
Speed			min	med	max	min	med	max	min	med	max
Total cooling capacity DF	(1)(E)	kW	1,56	1,85	2,35	2,31	2,83	3,38	3,19	4,04	4,31
Sensible cooling capacity DF	(1)(E)	kW	1,24	1,49	1,94	1,85	2,22	2,77	2,45	3,27	3,46
FCEER class DF	(E)		C			E			E		
Water flow		l/h	271	321	410	403	493	589	556	707	754
Water pressure drop	(E)	kPa	3	4	6	8	16	22	15	24	25
Heating capacity	(2)(E)	kW	2,53	2,88	3,55	3,15	3,62	4,22	4,42	5,25	5,61
FCCOP class	(E)		C			D			D		
Water flow	(2)	l/h	222	258	311	271	317	369	380	452	483
Water pressure drop	(2)(E)	kPa	4	5	8	5	9	12	10	14	15
Rated air flow		m ³ /h	289	366	533	306	487	640	479	717	805
Power input	(E)	W	18	23	42	35	55	73	44	67	75
Total sound power level	(3)(E)	dB(A)	33	37	45	39	43	50	47	56	58

ACQVARIA			AQ35Q0BB			AQ40Q0BB			AQ60Q0BB		
Speed			min	med	max	min	med	max	min	med	max
Total cooling capacity DF	(1)(E)	kW	3,50	4,39	4,68	4,73	6,60	7,45	5,83	8,48	9,00
Sensible cooling capacity DF	(1)(E)	kW	2,56	3,17	3,50	3,47	5,04	5,81	4,29	6,56	6,98
FCEER class DF	(E)		D			C			D		
Water flow		l/h	602	755	805	822	1148	1299	1010	1477	1571
Water pressure drop	(E)	kPa	8	12	15	10	20	25	16	31	34
Heating capacity	(2)(E)	kW	2,57	2,94	3,18	6,57	8,76	9,67	8,64	11,7	12,4
FCCOP class	(E)		E			C			C		
Water flow	(2)	l/h	221	253	273	634	840	929	757	1026	1083
Water pressure drop	(2)(E)	kPa	7	12	14	12	19	23	16	27	30
Rated air flow		m ³ /h	479	717	805	718	1147	1380	902	1544	1651
Power input	(E)	W	44	67	75	47	86	108	64	128	147
Total sound power level	(3)(E)	dB(A)	47	55	58	39	47	51	40	54	56

(1) Water temperature 7°C/12°C, air temperature dry bulb 27°C, wet bulb 19°C (47% relative humidity) according to EN1397:2021

(2) Water temperature 65°C / 55°C, air temperature 20°C

(3) Sound power measured according to standards ISO 3741 and ISO 3742

(E) EUROVENT certified data

Power supply 230-1-50 (V-ph-Hz)

Cassette unit ACQVARIA

DIMENSIONAL DRAWINGS

ACQVARIA 10-20-30-35

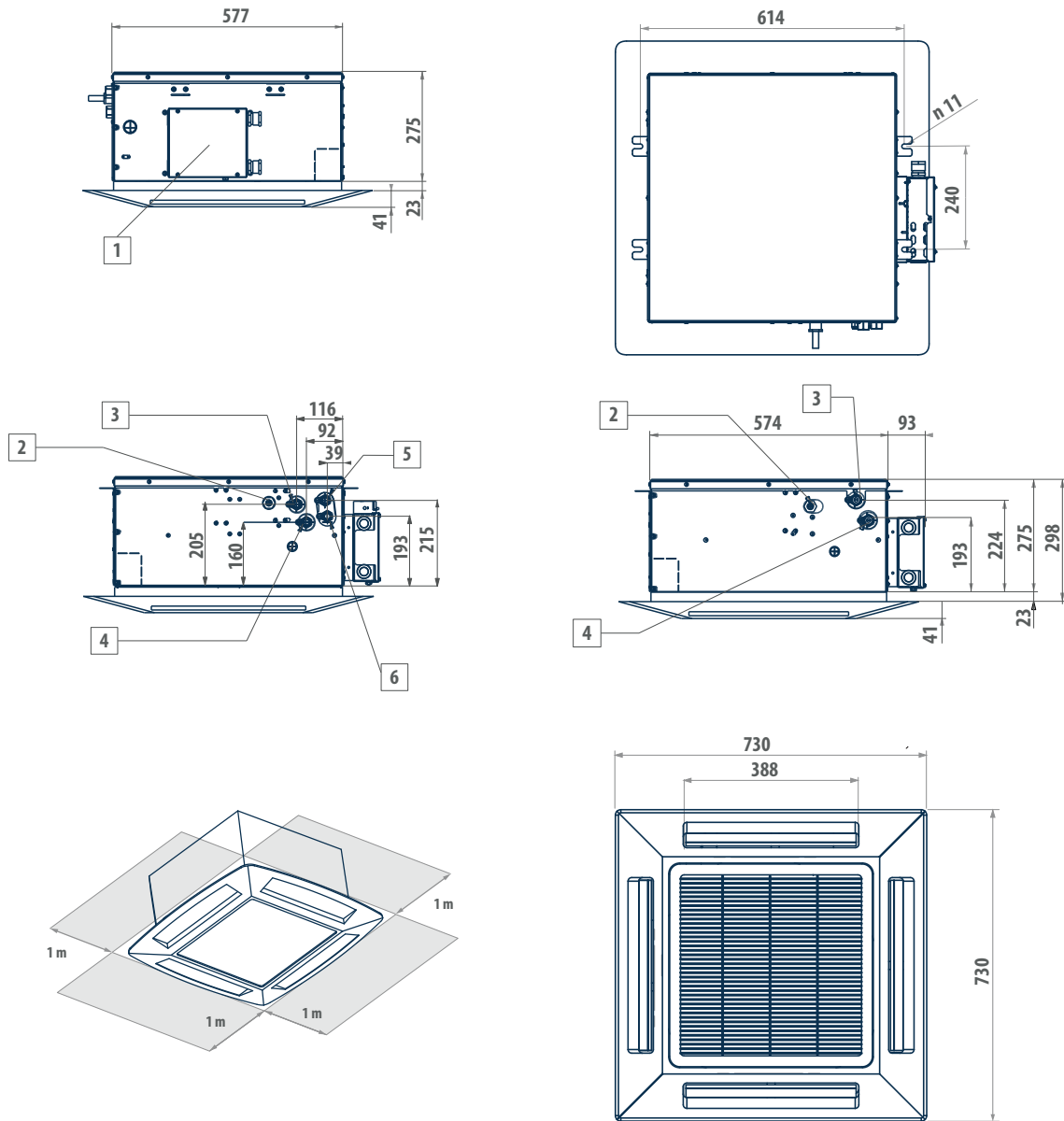

LEGEND

- | | |
|---|---|
| 1 | Electric box |
| 2 | Condensate discharge \varnothing 10 |
| 3 | Water outlet \varnothing 1/2" female gas |
| 4 | Water inlet \varnothing 1/2" female gas |
| 5 | Water outlet \varnothing 1/2" DF female gas |
| 6 | Water inlet \varnothing 1/2" DF female gas |

NOTE It is possible to combine the EFFETTO and EFFETTO AirClissi module with the ACQVARIA 60x60 cm cassette, for the dimensional drawing refer to page 83

ACQVARIA



kg

AQ10Q0B0 - AQ10Q0BB 23 + 2,5

AQ20Q0B0 - AQ30Q0B0 - AQ20Q0BB - AQ30Q0BB - AQ35Q0BB 24 + 2,5

DIMENSIONAL DRAWINGS

ACQVARIA 40, 50, 60 (Size 50 not available for dual coil version)

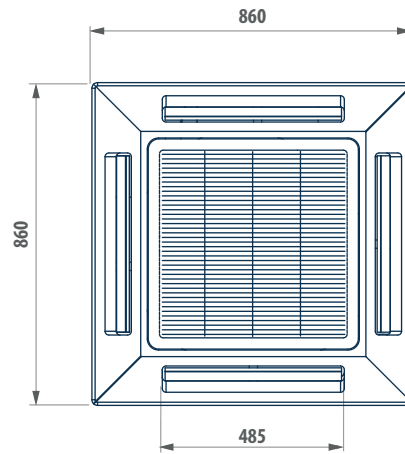
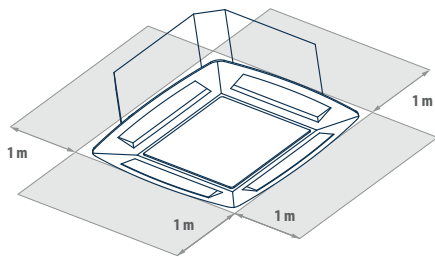
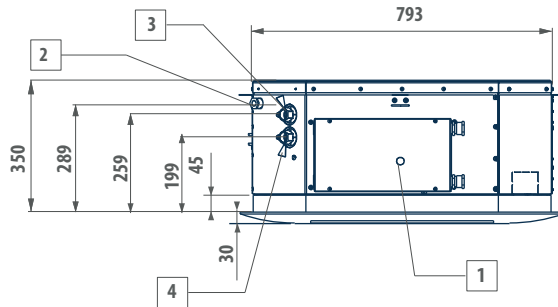
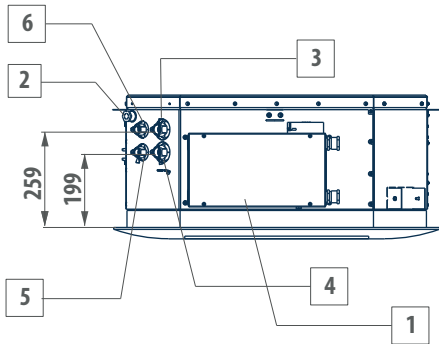
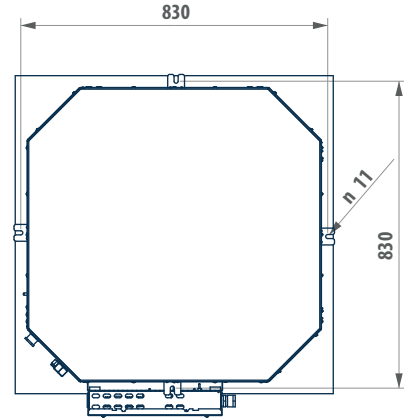
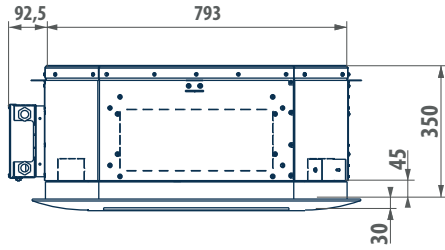

ACQVARIA	kg
AQ40Q0B0 - AQ40Q0BB	42 + 5
AQ50Q0B0 - AQ60Q0B0 - AQ60Q0BB	43 + 5

LEGEND

1	Electric box
2	Condensate discharge ø 10
3	Water outlet ø 3/4" female gas
4	Water inlet ø 3/4" female gas
5	Water inlet ø 1/2" DF female gas
6	Water outlet ø 1/2" DF female gas

Hydronic indoor unit - ACQVARIA

Cassette fan coils with EC motor

ACQVARIA i 3 – 10 kW

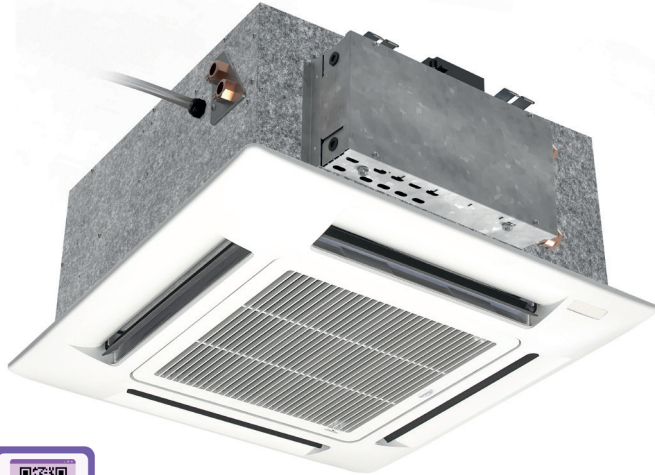

EC Motor



2 pipes systems



4 pipes systems



Recess ceiling-mount

PLUS

- » GreenTech Technology
- » Permanent magnet EC motor insures a precise, continuous control of operation
- » Low energy consumption
- » Fresh air with direct or mixed introduction
- » Condensate drainage pump for height differences of up to 0.9 m
- » Reduced installation and commissioning time

AVAILABLE VERSIONS

In addition to the 2 ABS grilles with adjustable fins it is available EFFETTO and EFFETTO AirClissi.

EFFETTO, module for intake and diffusion air with the Coandă effect

EFFETTO Airclissi, new design concept which integrates light with the Coandă effect air diffusion.



White RAL9003

STANDARD

White RAL9010



Grey - natural brushed aluminium



White - RAL 9010
EFFETTO

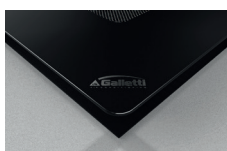

Black - black RAL 9005

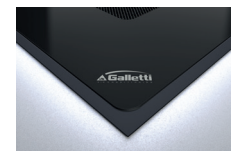

Neutral light
EFFETTO + AirClissi

Comfort, low noise, and efficiency in perfect harmony!

The new series of hydronic cassette units ACQVARIA i, with inverter-controlled permanent magnet EC motor, consists of six models for 2-pipe systems (10-20-30-40-50-60) and five models for 4-pipe systems (10-30-35-40-60). The engineering of the unit makes it possible to develop up to 5 kW in the cooling mode in a standard 600x600 mm modular suspended ceiling and over 10 kW in the 860x860 mm modularity, with exceptionally low noise levels in the phases for maintaining interior comfort.

The well-known advantages of EC motors are combined with GreenTech technology (in models 10, 20, 30 and 35), which integrates the inverter directly into the fan drive assembly.

ACQVARIA i leverages the entire Galletti, MYCOMFORT, EVO, and TED10 microprocessor controller platform that incorporate sophisticated adjustment logics based on air temperature, air humidity, and water temperature.

These benefits translate into greater accuracy in achieving and maintaining the desired comfort conditions through appropriate modulation of the fan speed as well as the reduction of noise emissions, which adapt to the actual thermal load.

Lastly, electricity consumption is reduced by up to 75% in comparison to conventional fixed-speed AC motors.

The suspended ceiling unit houses all the components, heat exchange coil, fan drive assembly, and condensate collection and drainage system. Its structure is designed for introducing fresh air into the space, mixing it with recovered air, and distributing the treated air from the cassette unit to adjacent rooms.

The design and colour, RAL9003 or RAL9010, of the air intake and diffusion louvre guarantee optimal integration into the suspended ceiling panels. Easy access to the air filter for cleaning operations.

The unit can be supplied complete with valves, including pressure-independent balancing and control valves, the use of which significantly reduces commissioning time.

MAIN COMPONENTS

Structure

Made of galvanised steel sheet with internal polyurethane foam coating and external flocked PES to guarantee heat and sound insulation. Fresh air can be introduced into the room directly through the unit due to the provision of connections for neutral or mixed introduction. Accessories are available for connection to ducts. There are systems on the unit for anchoring it to the ceiling. The electrical wiring is housed in a containment box and is easily accessible from the side for easy connection

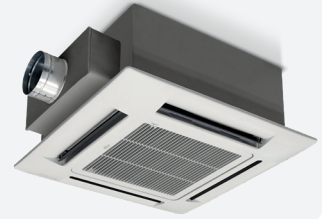

Heat exchanger

Copper pipe and high efficiency aluminium fins secured to the pipe by mechanical expansion. With at least two rows in the models for 2-pipe systems, it is available in the 2+1 configuration in the models for 4-pipe systems. The coil comes complete with manual air vent valves. On request, valves can be connected to the coil to regulate and balance the operation of the unit.

Fan drive assembly

Inverter-controlled permanent magnet EC electric motor (integrated in the Greentech models) directly connected to a centrifugal fan with backward-curving blades with profile optimised for stable operation at all speeds.

Air filter

Honey-comb polypropylene washable air filter, easily removable for maintenance operations.

Condensate collection and drainage system

Located under the heat exchanger, the main drip tray is made of polystyrene and is inserted inside the profiles optimised for the distribution of air in the space. The condensate drainage pump is able to raise the condensate up to 0.9 m from the exit point from the unit. The operation of the pump is controlled by a float switch with three levels of action that activate it, stop it and, if the critical level is exceeded, stop the operation of the cassette unit fan and close the water valve. The supply is completed by the auxiliary water drip tray for the collection of condensate from the regulating valves.

Louvre

It is square shaped for the intake and diffusion of air in the space, and it is made of ABS, colour RAL9003 or RAL9010. The air intake louvre can be opened for access to the air filter. Air is diffused in the space through the 4 sides, each of which is equipped with an adjustable fin with suitable thermal insulation.

Also available from today the new alluminium design module EFFETTO for intake and diffusion air with the Coandă effect.



Control mode

Galletti renews the fan coil control modes by integrating, on the EVO platform, the new EVO-2-TOUCH user interface and the NAVEL device for management with a smartphone.



EVO-2-TOUCH

is a user-friendly user interface with a 2.8" capacitive display with built-in temperature and humidity probes.

NAVEL

is the device paired with EVOBOARD that makes possible Wi-Fi or Bluetooth communication with a smartphone containing GALLETTI APP (available for iOS and Android).

ACCESSORIES

Electronic microprocessor control panels with display

DIST	MYCOMFORT controller spacer for wall mounting
EVO-2-TOUCH	2.8" touch screen user interface for EVO control
EVOBOARD	Circuit board for EVO control
EVODISP	User interface with display for EVO controller
EYNAVEL	Device for Wi-Fi or Bluetooth communication between EVOBOARD and smartphone
MCLE	Microprocessor control with display MYCOMFORT LARGE
MCSUE	Humidity sensor for MYCOMFORT LARGE and EVO
MCSWE	Water sensor for MYCOMFORT and EVO controllers

Electronic microprocessor control panels

TED 10	Electronic controller for BLDC fan equipped with inverter and ON/OFF valves 230 V
---------------	---

TED SWA	Water temperature sensor for TED controls
----------------	---

Valves

PIC-AQ	PRESSURE-INDEPENDENT 2-way valves
V2-AQ	2-way valve, ON/OFF or MODULATING actuator, 230 V or 24 V power supply, hydraulic kit, for model with 1 or 2 heat exchangers
V3-AQ	3-way valve, ON/OFF or MODULATING actuator, 230 V or 24 V power supply, hydraulic kit, for model with 1 or 2 heat exchangers

Plenum, air intake modules, air inlet and outlet connectors and cabinets

BAR	Spigot for introduction of mixed renewal air
MOB	Cabinet for cassette
PAR	Plenum for introduction of unmixed renewal air
PMAA	Air outlet plenum

Cassette units ACQVARIA i

RATED TECHNICAL DATA 2 PIPES

ACQVARIA i			AQ10QIB0				AQ20QIB0				AQ30QIB0			
				min	med	max		min	med	max		min	med	max
Speed			1	2	3	4	1	2	3	4	1	2	3	4
Control voltage		V	2,00	2,50	3,00	6,00	2,00	2,60	5,50	8,00	2,00	4,00	6,50	10,0
Total cooling capacity	(1)(E)	kW	1,62	2,15	2,35	3,21	1,62	2,19	3,40	4,47	1,54	2,76	3,95	5,23
Sensible cooling capacity	(1)(E)	kW	1,13	1,54	1,56	2,47	1,11	1,48	2,54	3,54	1,05	1,98	2,96	4,11
FCEER class	(E)		A				A				A			
Water flow	(1)	l/h	279	371	405	555	280	378	584	775	264	473	678	898
Water pressure drop	(1)(E)	kPa	6	10	10	16	4	7	15	22	3	9	18	29
Heating capacity	(2)(E)	kW	1,65	2,07	2,30	3,61	1,54	2,10	3,48	4,58	1,47	2,77	4,09	5,55
FCCOP class	(E)		A				A				B			
Water flow	(2)	l/h	286	355	395	621	267	361	605	797	255	481	711	965
Water pressure drop	(2)(E)	kPa	5	7	8	12	3	6	13	21	3	8	16	27
Rated air flow		m ³ /h	212	264	305	583	200	270	551	796	190	397	650	980
Power input	(E)	W	5	5	6	18	7	5	15	37	7	9	22	67
Total sound power level	(3)(E)	dB(A)	35	37	41	52	35	37	44	56	29	38	49	61

ACQVARIA i			AQ40QIB0				AQ50QIB0				AQ60QIB0			
			min	med	max			min	med	max		min	med	max
Speed			1	2	3	4	1	2	3	4	1	2	3	4
Control voltage		V	2,00	3,00	5,00	10,0	2,00	3,00	5,00	8,00	2,00	4,00	6,50	10,0
Total cooling capacity	(1)(E)	kW	4,80	5,36	6,39	8,27	5,17	5,92	7,26	9,01	5,26	6,70	8,37	10,5
Sensible cooling capacity	(1)(E)	kW	3,80	3,92	4,75	6,35	3,66	4,24	5,31	6,78	3,69	4,80	6,15	7,97
FCEER class	(E)		A				A				B			
Water flow	(1)	l/h	833	921	1097	1420	888	1015	1245	1545	902	1150	1436	1805
Water pressure drop	(1)(E)	kPa	12	16	21	34	10	13	18	27	10	15	22	33
Heating capacity	(2)(E)	kW	5,50	6,00	7,30	9,74	5,43	6,33	7,99	10,2	5,48	7,23	9,35	12,2
FCCOP class	(E)		A				B				B			
Water flow	(2)	l/h	953	1043	1269	1692	944	1100	1390	1779	952	1257	1625	2116
Water pressure drop	(2)(E)	kPa	3	16	23	38	9	12	19	29	9	15	23	36
Rated air flow		m ³ /h	843	978	1276	1916	724	864	1143	1554	710	976	1321	1831
Power input	(E)	W	14	18	36	150	14	18	36	93	14	25	60	150
Total sound power level	(3)(E)	dB(A)	35	39	45	57	35	39	48	53	36	43	50	58

(1) Water temperature 7°C/12°C, air temperature dry bulb 27°C, wet bulb 19°C (47% relative humidity) according to EN1397:2021

(2) Water temperature 45°C / 40°C, air temperature 20°C

(3) Sound power measured according to standards ISO 3741 and ISO 3742

(E) EUROVENT certified data

Power supply 230-1-50 (V-ph-Hz)

RATED TECHNICAL DATA 4 PIPES

ACQVARIA i			AQ10QIBB				AQ30QIBB				AQ35QIBB			
				min	med	max		min	med	max		min	med	max
Speed			1	2	3	4	1	2	3	4	1	2	3	4
Control voltage		V	2,00	3,50	4,50	6,00	2,00	2,50	4,80	10,0	2,00	4,00	6,50	10,0
Total cooling capacity	(1)(E)	kW	1,24	1,85	2,18	2,60	1,50	2,00	3,13	4,41	2,34	3,03	3,83	5,01
Sensible cooling capacity	(1)(E)	kW	0,92	1,46	1,79	2,23	1,05	1,15	2,25	3,58	1,49	2,17	2,79	3,98
FCEER class DF	(E)		A				A				A			
Water flow	(E)	l/h	213	317	374	447	264	344	539	759	403	521	659	862
Water pressure drop	(E)	kPa	2	4	6	8	3	7	13	25	4	6	10	17
Heating capacity	(2)(E)	kW	2,03	2,90	3,34	3,86	2,00	3,70	4,26	5,51	1,92	2,39	2,88	3,43
FCCOP class	(E)		A				A				B			
Water flow	(2)	l/h	178	254	292	338	178	318	367	474	165	206	248	295
Water pressure drop	(2)(E)	kPa	3	6	8	11	3	5	7	11	4	5	10	16
Rated air flow		m ³ /h	199	356	460	610	190	242	454	982	195	395	643	982
Power input	(E)	W	7	7	8	18	7	5	12	67	7	9	22	67
Total sound power level	(3)(E)	dB(A)	28	35	40	48	30	36	46	61	29	38	49	61

ACQVARIA i			AQ40QIBB				AQ60QIBB			
			min	med	max		min	med	max	
Speed			1	2	3	4	1	2	3	4
Control voltage		V	2,00	3,00	5,00	10,0	2,00	4,00	6,50	10,0
Total cooling capacity	(1)(E)	kW	4,61	5,34	6,61	9,07	4,70	6,09	7,62	9,50
Sensible cooling capacity	(1)(E)	kW	3,34	3,94	5,03	7,29	3,37	4,50	5,82	7,56
FCEER class DF	(E)		A				B			
Water flow	(E)	l/h	792	917	1135	1555	806	1045	1307	1631
Water pressure drop	(E)	kPa	12	15	22	37	11	17	25	37
Heating capacity	(2)(E)	kW	7,01	7,96	9,53	12,3	7,15	8,96	10,8	12,9
FCCOP class	(E)		A				B			
Water flow	(2)	l/h	613	697	834	1078	626	785	947	1133
Water pressure drop	(2)(E)	kPa	11	14	19	30	12	18	24	33
Rated air flow		m ³ /h	687	841	1137	1823	673	956	1314	1823
Power input	(E)	W	14	18	36	150	14	25	60	150
Total sound power level	(3)(E)	dB(A)	35	39	45	57	36	46	50	58

(1) Water temperature 7°C/12°C, air temperature dry bulb 27°C, wet bulb 19°C (47% relative humidity) according to EN1397:2021

(2) Water temperature 65°C / 55°C, air temperature 20°C

(3) Sound power measured according to standards ISO 3741 and ISO 3742

(E) EUROVENT certified data

Power supply 230-1-50 (V-ph-Hz)

Cassette units ACQVARIA i

DIMENSIONAL DRAWINGS

ACQVARIA i 10-20-30 (for 2 pipes) - 10-30-35 (for 4 pipes)

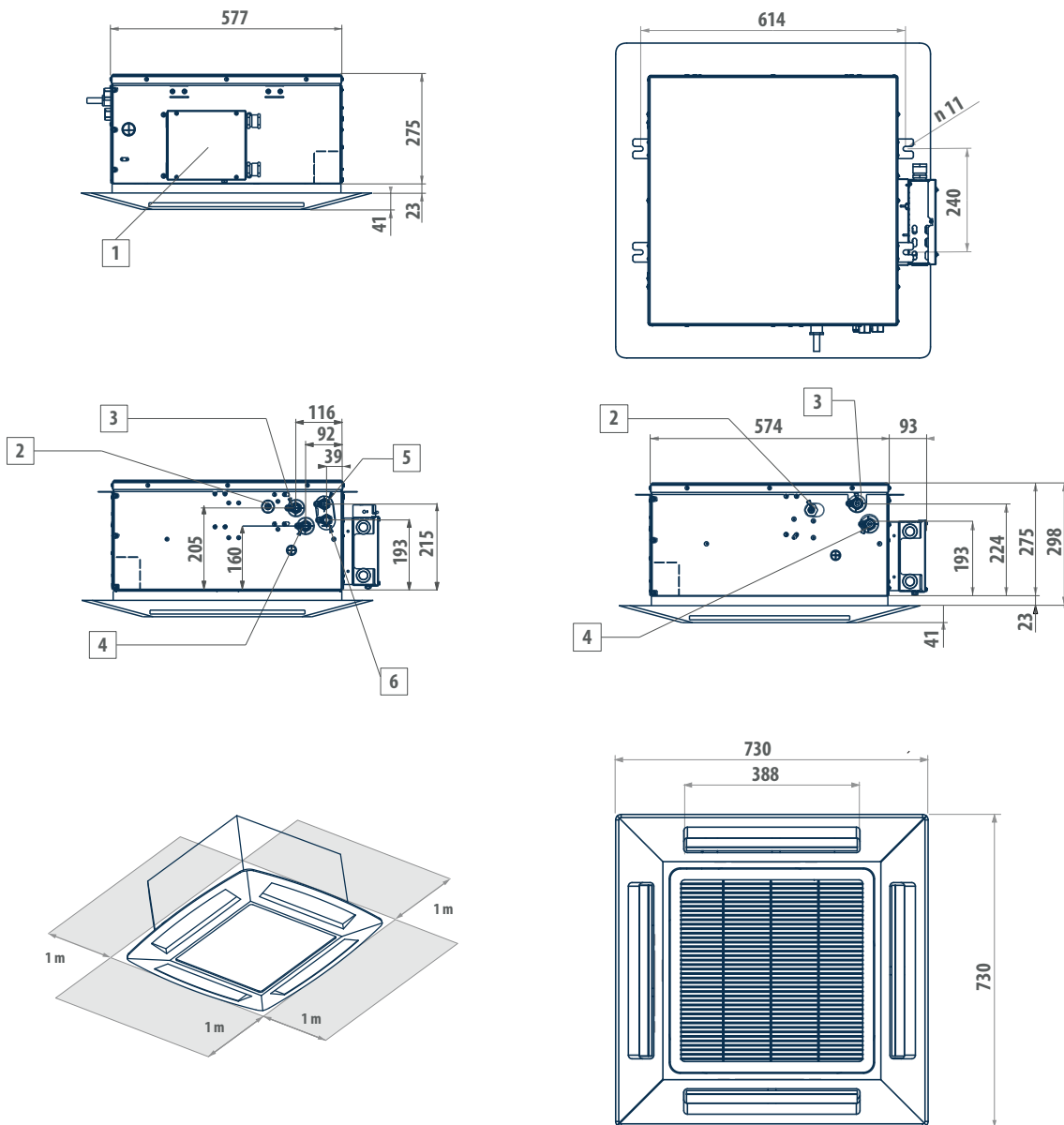

LEGEND

- | | |
|---|---|
| 1 | Electrical cable passage |
| 2 | Condensate discharge \varnothing 10 |
| 3 | Water outlet \varnothing 1/2" female gas |
| 4 | Water inlet \varnothing 1/2" female gas |
| 5 | Water outlet \varnothing 1/2" DF female gas |
| 6 | Water inlet \varnothing 1/2" DF female gas |

NOTE It is possible to combine the EFFETTO and EFFETTO AirClissi module with the ACQVARIA i 60x60 cm cassette, for the dimensional drawing refer to page 83

ACQVARIA i



kg

AQ10QIB0 - AQ10QIBB 23 + 2,5

AQ20QIB0 - AQ30QIB0 -
AQ30QIBB - AQ35QIBB 24 + 2,5

DIMENSIONAL DRAWINGS

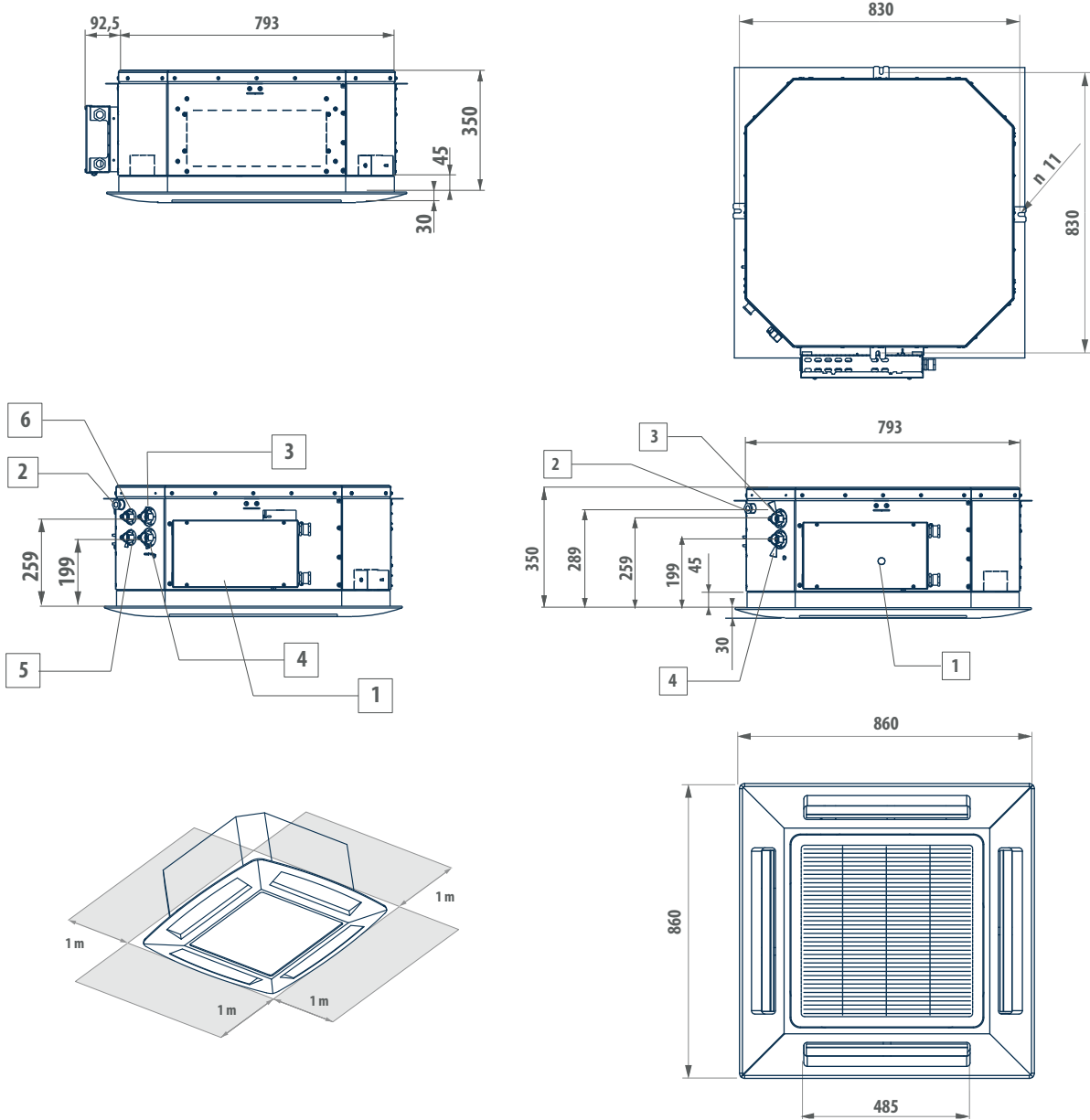
ACQVARIA i 40, 50, 60 (Size 50 not available for dual coil version)

Mod.	kg
AQ40QIB0	42 + 5
AQ50QIB0	43 + 5
AQ60QIB0	43 + 5
AQ40QIBB	42 + 5
AQ60QIBB	43 + 5

LEGEND

1	Electric box
2	Condensate discharge \varnothing 10
3	Water outlet \varnothing 3/4" female gas
4	Water inlet \varnothing 3/4" female gas
5	Water inlet \varnothing 1/2" DF female gas
6	Water outlet \varnothing 1/2" DF female gas

High available head duct fancoil units

FHP 1 - 4 kW



FHP is new high available head duct fancoil units.

The series offers an air flow range from 280 to 650 m³/h, with a total of 6 models featuring high-efficiency heat exchange coils.

The fan coil unit is enhanced compared to traditional fan coils to ensure a useful static pressure of 50 and 60 Pa at medium and maximum speeds, respectively. It is classified as a ductable unit by Eurovent.

It is a versatile fan coil that allows horizontal and vertical installation. In fact, FHP is equipped with a double condensate collection tray. With a height of only 22.4 cm, it is perfect for any type of false ceiling.

FHP can be installed in offices, hospitality facilities, and light commercial spaces, as well as in residential buildings, where there are often stringent requirements related to noise levels and installation spaces.

It comes with a plethora of factory-installable options and accessories, such as control panels, plenums, and fittings, to provide everything needed for the HVAC installer.



PLUS

- » PSU of 50 Pa at medium speed
- » Compact dimensions
- » Reversible water connections
- » Compatible with zoning systems

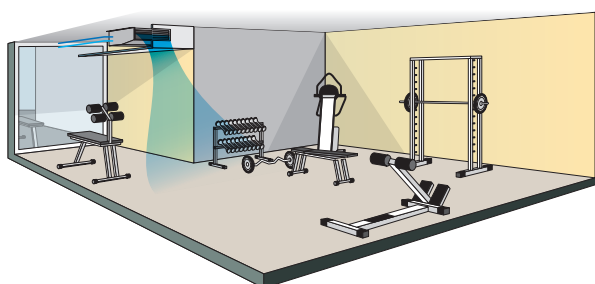
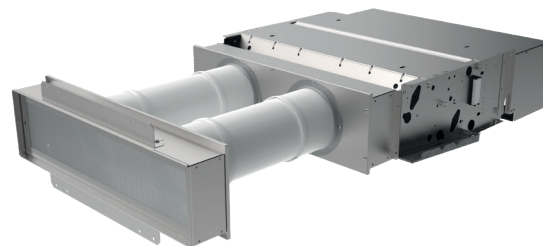

MAIN COMPONENTS

Structure

Built from galvanised steel sheet of extra thickness, heat and sound insulated by means of Class 1 self-extinguishing panels, complete with double drip tray for collecting condensate.

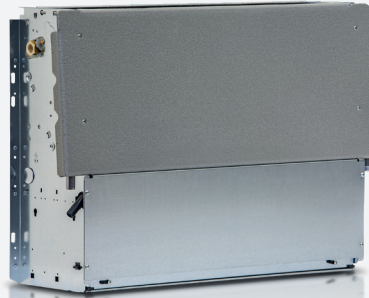

Heat exchanger

High efficiency heat exchanger made with copper piping and aluminium fins, provided with brass manifolds and vent valve. The water connections are reversible at the time of installation. On request it is possible to mount an additional heat exchanger for 4-pipe systems.

Electric motor

It is mounted on vibration dampers, with permanently activated capacitor and thermal protection of the windings, and is directly coupled with the fans. It is available as 3-speed version in order to meet all the specific needs of performance, quietness, and power consumption.

Fans

Double suction centrifugal fans, statically and dynamically balanced, manufactured from anti-static ABS, with blades having an airfoil section and offset modules. The fans are housed in a low-noise ABS volute with high-efficiency profile.

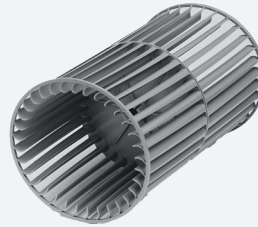

Air filter

Honey-comb polypropylene washable air filter, easily removable for maintenance operations. Filter with G2 filtration class also available.

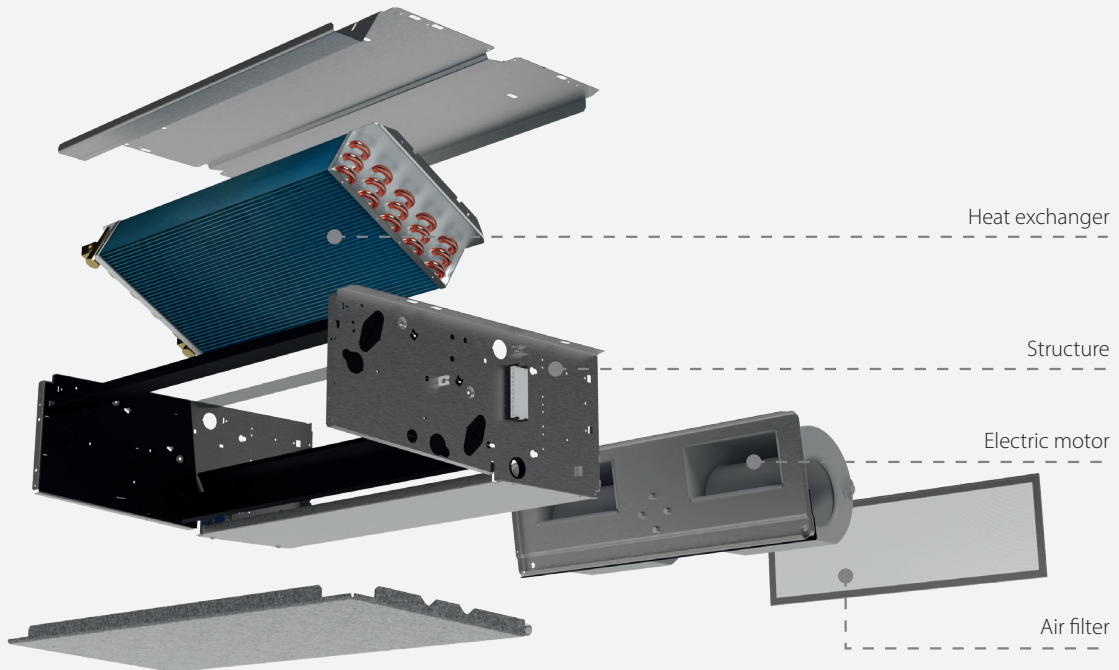

Fan Coil FHP

CONFIGURATOR

The models are completely configurable by selecting the version and the options. To the right is shown an example of configuration.

Version	Field	1	2	3	4	5	6	7	8	9	10	11
ED05		C	0	L	0	1	0	0	6	0	0	A

ED Product type FHP; 05 Size

To verify the compatibility of the options, use the selection software or the price list.

CONFIGURATOR

1 Version

C Recessed installation

2 Motor

0 3-speed motor

3 Main coil hydraulic side

L Water connections on the left side

R Water connections on the right

4 Additional coil hydraulic side / heating element

0 Absent

L Water connections on the left side

R Water connections on the right

5 Valve

0 Absent

1 VKS - 3 ways valve - 230 V - ON/OFF - complete hydraulic kit

2 KV - 2 ways valve - 230 V - ON/OFF

6 Control panel

0 Absent

E EVOBOARD - Circuit board

G EVOBOARD circuit board + NAVEL Wi-Fi module

7 Probes

0 Absent

1 SA - Remote air probe for MYCOMFORT and EVO

2 SW - Water probe for MYCOMFORT and EVO

3 SU - Humidity probe for MYCOMFORT and EVO

4 SA+SW - Remote air and water probes for MYCOMFORT and EVO

5 SA+SU - Remote air and humidity probes for MYCOMFORT and EVO

6 SA+SU+SW- Remote air, water, humidity probes for MYCOMFORT and EVO

8 Accessories

0 Absent

4 BV - Auxiliary drip tray

5 BH - Auxiliary drip tray

6 GIVK - Insulating shell

9 Filter

0 Standard filter air

1 G2 Filter air

10 Release

0 0

A A

CONTROL PANELS

Electronic microprocessor control panels with display

DIST MYCOMFORT controller spacer for wall mounting

EVO-2-TOUCH 2.8" touch screen user interface for EVO control

EVOBOARD Circuit board for EVO control

EVO DISP User interface with display for EVO controller

EYNAVEL Device for Wi-Fi or Bluetooth communication between EVOBOARD and smartphone

MCBE MYCOMFORT BASE electronic controller with display

MCLE Microprocessor control with display MYCOMFORT LARGE

MCSUE Humidity sensor for MYCOMFORT LARGE and EVO

MCSWE Sonda acqua per comandi MYCOMFORT and EVO

Electronic microprocessor control panels

TED 2T Electronic controller for AC fan control and one ON/OFF 230 V valve

TED 4T Electronic controller for AC fan control and two ON/OFF 230 V valves

TED SWA Water temperature sensor for TED controls

ACCESSORIES

Auxiliary water drip trays, insulating shell, condensate drainage pump

BH Auxiliary water drip tray for horizontal installation fan coil units

BV Auxiliary water drip tray for vertical installation fan coil units

KSC Condensate drainage pump kit

Power interface and regulating louver controllers

CSD Recess mounted controller for opening and closing the SM motor-driven regulating louver

Base and enclosure elements

D Support elements

Air inlet and outlet grilles

GE Aluminium external air intake grille with subframe

GEF Aluminium external air intake grille with subframe and air filter

GM Aluminium air outlet grille with 2-row fins and subframe

RGC Plenum with circular collars for air outlet grille

Auxiliary water drip trays, insulating shell, condensate drainage pump

GIVKL Insulating shell for VKS valve, water connections on the left

GIVKR Insulating shell for VKS valve, water connections on the right

Power interface and regulating louver controllers

KP Power interface for connecting in parallel up to 4 fan coil units to the one controller

Electrical heating elements

RE Heating element with installation kit, relay box and safety devices

Plenum and connectors

RA90 Angular inlet connector

RAD Straight inlet connector

RADC Air inlet plenum with circular collars

RM90 Angular outlet connector

RM90C Angular outlet insulated connector

RMCD Straight outlet insulated connector

RMCD C Air outlet plenum with circular collars

RMD Straight outlet connector

External air intake louvers

S Manual external air intake louver

SM Motor-driven louver, with motor on the right with transformer

SM Motor-driven louver, with motor on the left with transformer

SMC Motor driven louver, with motor on the right, with transformer

SMC Motor driven louver, with motor on the left, with transformer

Valves

VKDF 3-way valve, ON/OFF actuator, 230 V power supply, complete hydraulic kit for additional heat exchanger

VKS 3-way valve, ON/OFF actuator, 1230 V power supply, complete hydraulic kit for main heat exchanger

KV 2-way valve, ON/OFF actuator, hydraulic kit on water connection side for main heat exchanger

KVDF 2-way valve, ON/OFF actuator, 230 V power supply, hydraulic kit on water connection side for main and additional heat exchanger

2 PIPES - RATED TECHNICAL DATA

FHP			3			4			5			6		
Speed			min	med	max	min	med	max	min	med	max	min	med	max
Declared speed			1,2,3											
Rated air flow		m ³ /h	190	220	280	190	220	280	270	370	470	270	370	470
Available static pressure		Pa	35	50	60	35	50	60	28	50	60	28	50	60
Power input	(E)	W	57	65	100	57	65	100	47	63	114	45	60	110
Total cooling capacity	(1)(E)	kW	0,97	1,09	1,17	1,19	1,31	1,55	1,52	2,24	2,39	1,76	2,64	3,03
Sensible cooling capacity	(1)(E)	kW	0,80	0,90	0,99	0,84	0,96	1,14	1,11	1,54	1,72	1,35	1,98	2,38
FCEER class	(E)		E			E			D			D		
Water flow	(1)	l/h	167	187	202	205	225	267	262	385	411	303	454	521
Water pressure drop	(1)(E)	kPa	6	7	9	4	5	6	8	13	13	8	11	13
Heating capacity	(2)(E)	kW	1,12	1,25	1,50	1,20	1,45	1,75	1,86	2,39	2,75	2,04	2,68	3,11
FCCOP class	(E)		E			E			D			C		
Water flow	(2)	l/h	192	216	258	206	249	300	320	411	473	350	461	535
Water pressure drop	(2)(E)	kPa	6	7	9	4	5	6	8	12	14	8	11	14
Total sound power level	(3)(E)	dB(A)	48	53	55	48	53	55	48	55	58	48	55	58
Inlet + radiated sound power level	(3)	dB(A)	46	51	53	46	51	53	46	53	56	46	53	56
Outlet sound power level	(3)	dB(A)	45	50	52	45	50	52	45	52	55	45	52	55

FHP			8			9		
Speed			min	med	max	min	med	max
Declared speed			1,2,3					
Rated air flow		m ³ /h	370	480	500	440	530	650
Available static pressure		Pa	28	50	60	35	50	60
Power input	(E)	W	53	85	120	60	75	120
Total cooling capacity	(1)(E)	kW	2,62	3,40	3,52	3,07	3,74	4,20
Sensible cooling capacity	(1)(E)	kW	1,87	2,37	2,45	2,19	2,56	3,04
FCEER class	(E)		C					
Water flow	(1)	l/h	451	585	605	528	644	722
Water pressure drop	(1)(E)	kPa	11	17	18	15	20	23
Heating capacity	(2)(E)	kW	2,74	3,53	3,64	3,18	3,83	4,52
FCCOP class	(E)		C					
Water flow	(2)	l/h	472	607	627	547	659	777
Water pressure drop	(2)(E)	kPa	12	18	19	15	20	23
Total sound power level	(3)(E)	dB(A)	49	56	58	52	57	59
Inlet + radiated sound power level	(3)	dB(A)	47	54	56	50	55	57
Outlet sound power level	(3)	dB(A)	46	53	55	49	54	56

(1) Water temperature 7°C/12°C, air temperature dry bulb 27°C, wet bulb 19°C (47% relative humidity) according to EN1397:2021

(2) Water temperature 45°C / 40°C, air temperature 20°C

(3) Sound power measured according to standards ISO 3741 and ISO 3742

(E) EUROVENT certified data

Power supply 230-1-50 (V-ph-Hz)

4 PIPES - RATED TECHNICAL DATA

FHP			3			4			5			6		
Speed			min	med	max	min	med	max	min	med	max	min	med	max
Declared speed			1,2,3											
Rated air flow	(E)	m ³ /h	180	210	270	180	210	270	260	360	450	260	360	450
Available static pressure	(E)	Pa	35	50	58	35	50	58	28	50	58	28	50	58
Power input	(E)	W	57	65	100	57	65	100	47	63	114	45	60	110
Total cooling capacity	(1)(E)	kW	0,94	1,05	1,14	1,15	1,27	1,50	1,48	2,17	2,32	1,71	2,56	2,94
Sensible cooling capacity	(1)(E)	kW	0,78	0,87	0,96	0,82	0,93	1,11	1,07	1,49	1,67	1,31	1,92	2,31
FCEER class	(E)		E			E			D			D		
Water flow	(2)	l/h	162	181	196	199	219	259	254	374	398	294	440	505
Water pressure drop	(2)(E)	kPa	6	7	9	4	5	6	8	13	13	8	11	13
Heating capacity	(3)(E)	kW	1,22	1,38	1,58	1,22	1,38	1,58	1,81	2,22	2,55	1,81	2,22	2,55
FCCOP class	(E)		E			E			D			D		
Water flow	(3)	l/h	210	237	272	210	237	272	311	382	439	311	382	439
Water pressure drop	(3)(E)	kPa	4	5	7	4	5	7	2	3	3	2	3	3
Total sound power level	(4)	dB(A)	48	53	55	48	53	55	48	55	58	48	55	58
Inlet + radiated sound power level	(4)(E)	dB(A)	46	51	53	46	51	53	46	53	56	46	53	56
Outlet sound power level	(4)(E)	dB(A)	45	50	52	45	50	52	45	52	55	45	52	55

FHP			8			9		
Speed			min	med	max	min	med	max
Declared speed			1,2,3					
Rated air flow	(E)	m ³ /h	360	460	480	420	510	630
Available static pressure	(E)	Pa	28	50	58	35	50	58
Power input	(E)	W	53	85	120	60	75	120
Total cooling capacity	(1)(E)	kW	2,54	3,30	3,41	2,98	3,63	4,07
Sensible cooling capacity	(1)(E)	kW	1,82	2,30	2,37	2,13	2,49	2,95
FCEER class	(E)		C					
Water flow	(2)	l/h	437	567	587	512	625	700
Water pressure drop	(2)(E)	kPa	11	17	18	15	20	23
Heating capacity	(3)(E)	kW	2,73	3,15	3,22	3,00	3,35	3,84
FCCOP class	(E)		C					
Water flow	(3)	l/h	470	542	554	516	576	660
Water pressure drop	(3)(E)	kPa	3	4	5	4	5	7
Total sound power level	(4)	dB(A)	49	56	58	52	57	59
Inlet + radiated sound power level	(4)(E)	dB(A)	47	54	56	50	55	57
Outlet sound power level	(4)(E)	dB(A)	46	53	55	49	54	56

(1) Water temperature 7°C/12°C, air temperature dry bulb 27°C, wet bulb 19°C (47% relative humidity) according to EN1397:2021

(2) Water temperature 7°C / 12°C, air temperature dry bulb 27°C, wet bulb 19°C (47% relative humidity)

(3) Water temperature 65°C / 55°C, air temperature 20°C

(4) Sound power measured according to standards ISO 3741 and ISO 3742

(E) EUROVENT certified data

Power supply 230-1-50 (V-ph-Hz)

DIMENSIONAL DRAWINGS

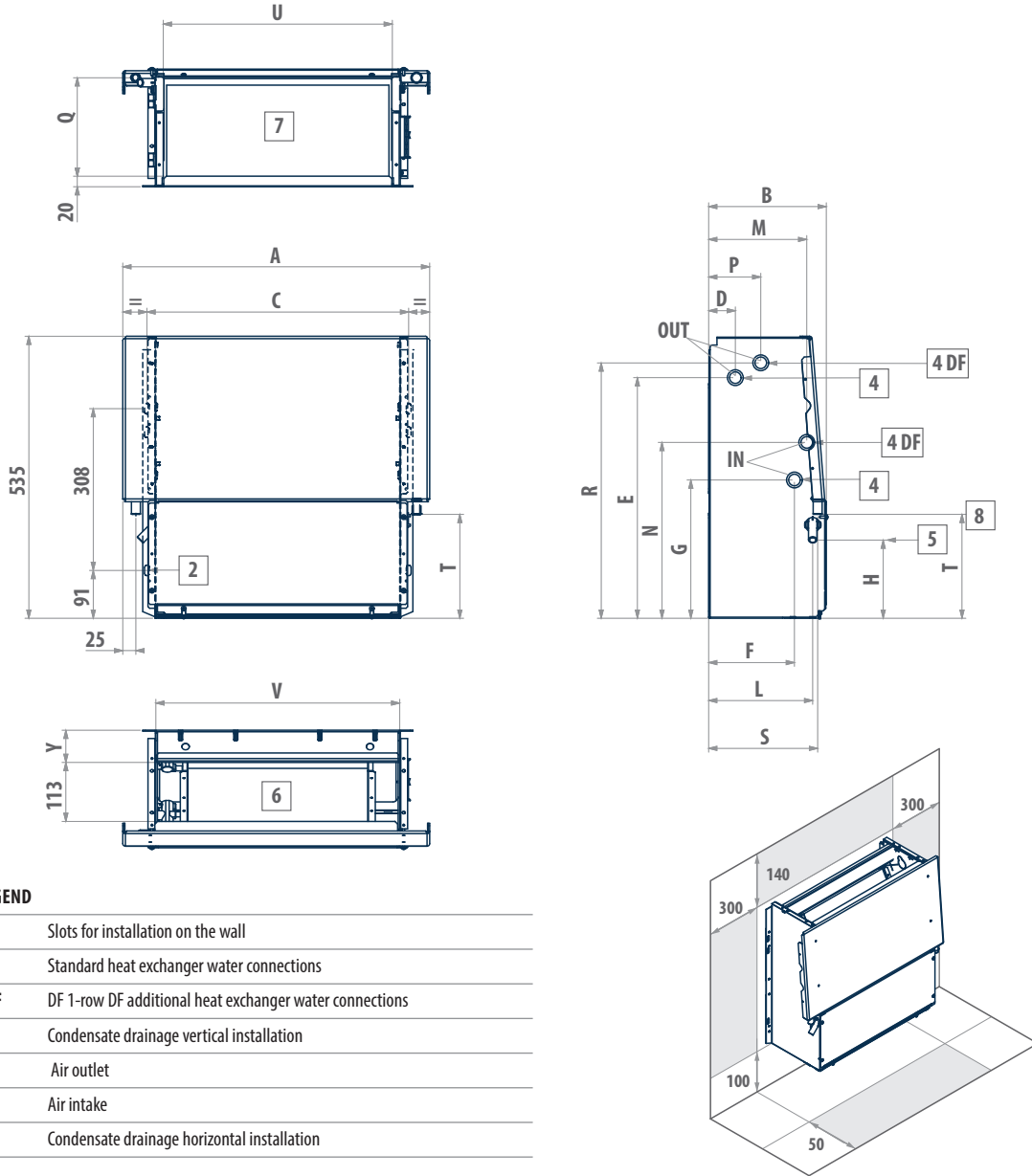
FHP

LEGEND

2	Slots for installation on the wall
4	Standard heat exchanger water connections
4DF	DF 1-row DF additional heat exchanger water connections
5	Condensate drainage vertical installation
6	Air outlet
7	Air intake
8	Condensate drainage horizontal installation

FHP	A	B	C	D	E	F	G	H	L	M	N	P	Q	R	S	T	U	V	Y	4	📦
	mm	mm	mm	mm	mm	mm	mm	mm	mm	mm	mm	mm	mm	mm	mm	mm	mm	mm	mm	"	kg
3-4	584	224	498	51	458	163	263	149	198	187	335	99	189	486	208	198	436	464	61	1/2	18
5-6	794	224	708	51	458	163	263	149	198	187	335	99	189	486	208	198	646	674	61	1/2	23
8-9	1004	224	918	51	458	163	263	149	198	187	335	99	189	486	208	198	856	884	61	1/2	27

Wired plenum with motorized dampers

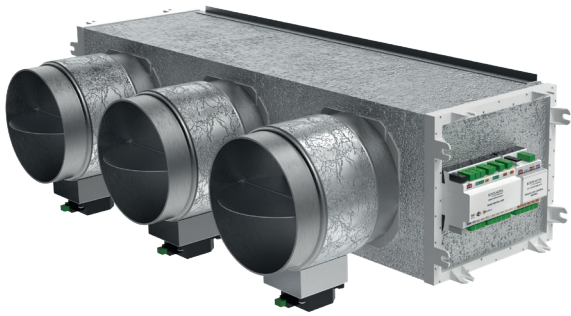
DMP



AC Motor



EC Motor



2 pipes systems



4 pipes systems

PLUS

- » Independent control of the air set point in each zone
- » Sizing of Ductimax according to the actual simultaneous usage
- » Wireless connection between controls and control unit
- » Automatic configuration of command parameters
- » Thermally and acoustically insulated PAL plenums, 85% lighter than using galvanized sheet metal.

The Importance of Zoning

In recent years, it has become increasingly evident that energy savings are not only achieved through the introduction of components, systems, or installations aimed at improving mere energy performance but also through other factors such as the efficient and effective control of their correct use.

It is very important that the building's energy consumption is based on actual needs, taking into account the real occupancy of the premises by people.

According to this philosophy, Galletti has introduced DMP, the wired plenum with a control unit and motorized dampers for advanced air management in ducted air conditioning systems.

Thanks to the integrated control unit, it is possible to precisely and automatically control the opening and closing of the dampers, optimizing the distribution of air in the different zones of the building.

This configuration improves energy efficiency, ensures customized comfort, and reduces installation times, making it ideal for complex and high-performance systems. In fact, most of the electrical connections are already made at the factory on the plenum, and thanks to the radio wave touch screen controls, no wiring to the control unit is necessary. The setting of operating parameters is automatic and instantaneous.

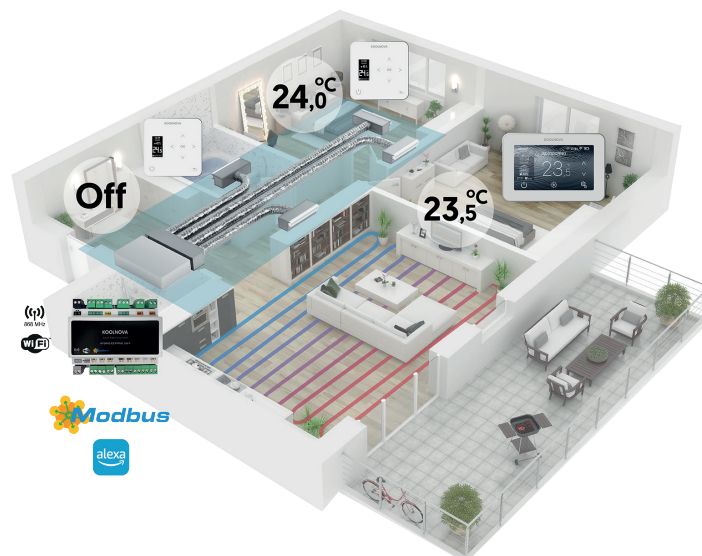

MAIN COMPONENTS

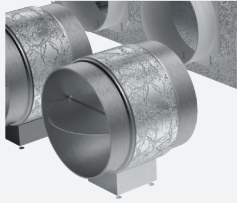

Motor-driven louver

Motorized steel duct damper with galvanized finish.

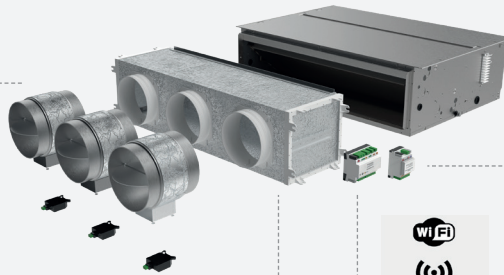

PAL panel plenum

Made of thermally and acoustically insulated expanded polyurethane. Compatible with 2, 3, and 4 motorized dampers Ø 200 mm.



Interface for managing the fan coil

This device allows the management of the following fan coil functions: on-off and fan speed with AC and EC motors; operating modes; 230 V on-off valves; connection to supervision systems via Bus.

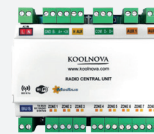
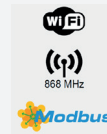

Control unit for managing motorized dampers

Universal configurable control unit for system management via radio interfaces. Includes Wi-Fi module for managing all functions through the application (APP KOOLNOVA), allowing remote viewing and management of air-conditioned rooms.

CONTROL PANELS

RC1M master touch screen control with radio waves

Graphic interface with 4.3" screen and metallic and glass finishes, radio communication.

- Radio communication without wiring (range 50 meters).
- Control of operating modes (hot, cold).
- Selection of room temperature in 0.5°C intervals.
- Zone On-Off.
- System Stop (MASTER).
- Temperature and fan speed control of the unit.
- Monitoring of ambient temperature and relative humidity per zone.
- SLEEP Function.
- Time schedules
- Powered by a rechargeable lithium-ion battery with USB cable, includes mounting base and a Micro USB to USB cable.



RC1S slave touch screen control with radio waves

1.3" OLED screen, backlit capacitive buttons, and metallic color finishes.

- Radio communication without wiring (range 50 meters)
- Selection of nominal temperature in 0.5°C intervals.
- Zone On-Off.
- Reading of ambient temperature and relative humidity of the zone.
- SLEEP Function.
- Powered by a rechargeable lithium-ion battery with USB cable.

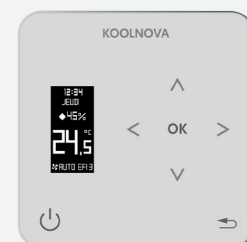

Duct units DUCTIMAX and DUCTIMAX i

COMPATIBILITY TABLE BETWEEN:

Ductimax/Ductimax i and DMP plenum

Compatibility	Galletti code	Description	Galletti code	Description
Ductimax frame 1÷2 DM13-DM14-DM23-DM24	DMP2MD1	Plenum with 2 motorized dampers + electronic board for damper management and radio antenna + fan coil interface	EYRC1M1S	2 touch screen radio wave commands (1 master, 1 slave)
Ductimax frame 3÷4 DM33-DM34-DM43-DM44	DMP3MD3	Plenum with 3 motorized dampers + electronic board for damper management and radio antenna + fan coil interface	EYRC1M2S	3 touch screen radio wave commands (1 master, 2 slaves)
Ductimax frame 5÷6 DM53-DM54-DM63-DM64	DMP4MD5	Plenum with 4 motorized dampers + electronic board for damper management and radio antenna + fan coil interface	EYRC1M3S	4 touch screen radio wave commands (1 master, 3 slaves)

DIMENSIONAL DRAWINGS

DMP2MD1

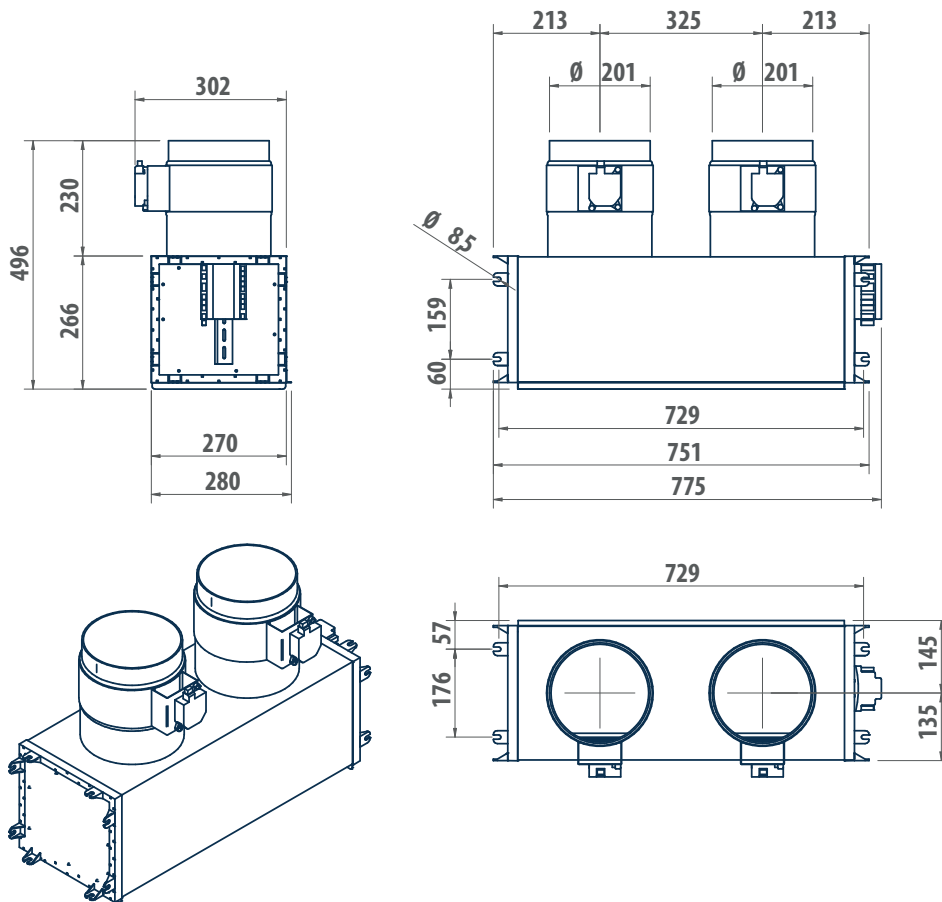

LEGEND

Available for Ductimax frame 1÷2 (DM 13-14); (DM 23-24)

DMP2MD1: Plenum with 2 motorized dampers + electronic board for damper management and radio antenna + fan coil interface

EYRC1M1S: 2 touch screen radio wave commands (1 master, 1 slave)

DMP3MD3

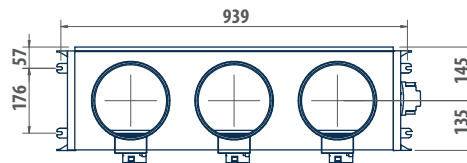
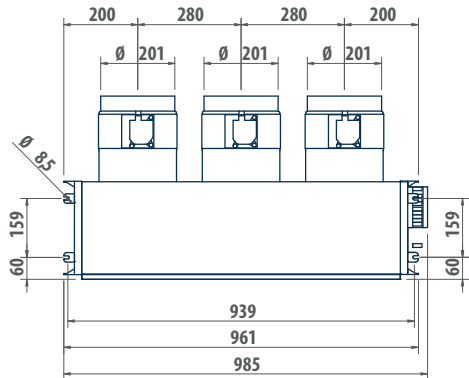
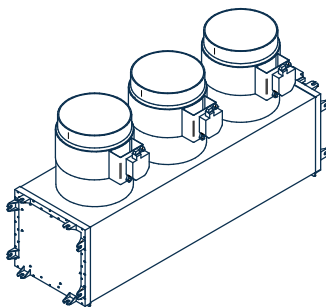
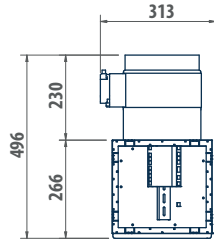

LEGEND

Available for Ductimax frame 3÷4 (DM 33-34); (DM 43-44)

DMP3MD3: Plenum with 3 motorized dampers + electronic board for damper management and radio antenna + fan coil interface

EYRC1M2S: 3 touch screen radio wave commands (1 master, 2 slaves)

DMP4MD5

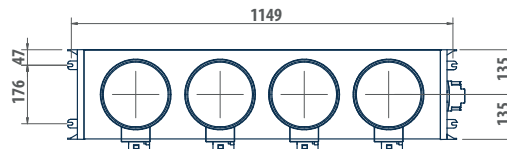
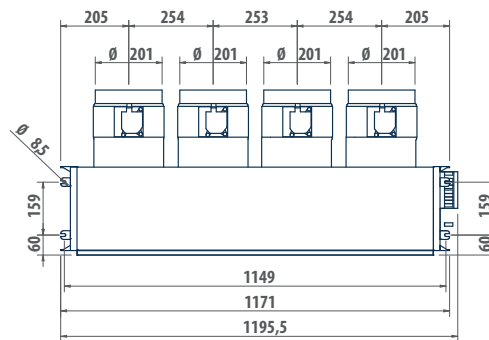
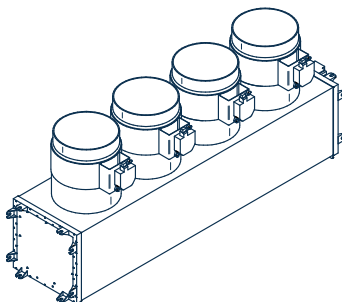
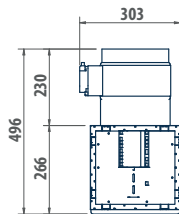

LEGEND

Available for Ductimax frame 5÷6 (DM 53-54); (DM 63-64)

DMP4MD5: Plenum with 4 motorized dampers + electronic board for damper management and radio antenna + fan coil interface

EYRC1M3S: 4 touch screen radio wave commands (1 master, 3 slaves)

Medium available head duct units

DUCTIMAX 2 - 8 kW

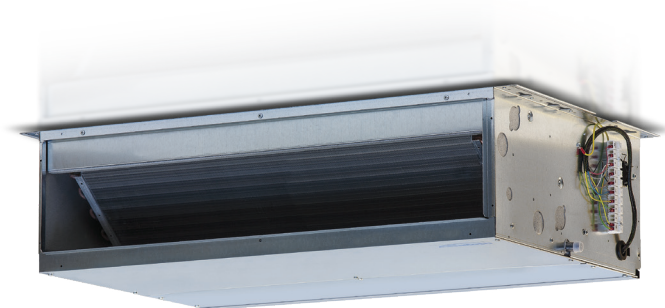

Performance and compactness in recessed ceiling installations

The DUCTIMAX ducted unit has been conceived for air conditioning interiors where the installation of high-performance medium head units with reduced overall dimensions is required. The range features 12 models with air flows of from 300 to 1200 m³/h. The heat exchanger enables DUCTIMAX to be used under a whole variety of operating conditions. The weight-bearing structure in fact houses a 3- or 4-rows exchanger which can be combined with an additional 1 or 2-rows exchanger (on request) for exceptional performance even with low temperature differentials. The heat exchangers can be optimized for centralized applications such as district cooling. DUCTIMAX is designed for horizontal ceiling installation. The main condensate drip tray is situated inside the structure of the unit and is at a positive pressure relative to the drain outlet to facilitate condensate drainage.

A wide range of wall-mounted controllers is available, including controllers of an electromechanical type and microprocessor controllers with display.

Heating elements complete with safety devices are available to supplement the hydronic system.

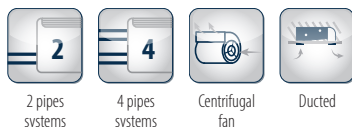

PLUS

- » Multi speed motor
- » Heat exchanger up to 4 rows
- » Reversible water connections
- » ABS centrifugal fans

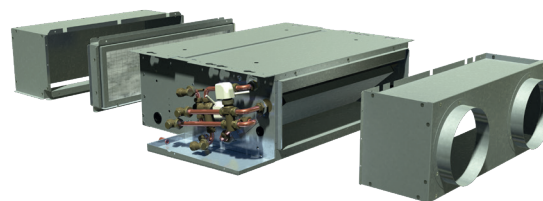

COMPATIBLE WITH PLENUM DMP

The bearing structure allows to combine a large range of accessories in suction and air delivery in order to obtain the optimized unit configuration.

AVAILABLE VERSIONS

DMXXD0L0...A Units for 2 pipes systems
DMXXD0LL...A Unit for 4-pipe systems equipped with an additional 1-row exchanger for the hot water circuit

DMXXD0LM...A Unit for 4-pipe systems equipped with an additional 2-row exchanger for the hot water circuit
(On request)

MAIN COMPONENTS

Structure

Built from galvanised steel sheet, heat and sound insulated by means of Class 1 self-extinguishing panels. Reduced height to facilitate installation in a horizontal position in a false ceiling. The structure incorporates a drip tray and condensate drain outlet.

Heat exchanger

High efficiency 3 and 4 rows heat exchanger made with copper piping and aluminium fins blocked to pipings by mechanical expansion, provided with brass manifolds and air vent valve. The heat exchanger usually comes with water connections mounted on the left, but it can be turned by 180°. High-efficiency heat exchangers optimized for district cooling applications are available on request.

Electric motor

Single-phase asynchronous multi-speed electric motor with permanently connected capacitor and thermal protector, mounted on vibration-damping supports.

Fans

Double suction centrifugal fans made with ABS or aluminium, with statically and dynamically balanced forward-curving blades, directly coupled to the electric motor.

Air filter

Washable air filter, made of acrylic fibre, filtration class G2, G3 or G4, applied on the air intake; may be pulled out from below.

CONFIGURATOR

The models are completely configurable by selecting the version and the options. To the right is shown an example of configuration.

Version	Field	1	2	3	4	5	6	7	8	9	10	11
DM44		D	I	L	0	1	E	0	0	3	0	A

To verify the compatibility of the options, use the selection software or the price list.

CONFIGURATOR

- | | |
|--|---|
| <p>1 Version
D Ducted version</p> <p>2 Motor
0 3-speed motor
1 7-speed motor
I BLDC motor
P 6 speed motor</p> <p>3 Main coil hydraulic side
L Water connections on the left side
R Water connections on the right</p> <p>4 Additional coil hydraulic side / heating element
0 Absent
E RE - Electrical heating elements
L Water connections on the left side
R Water connections on the right</p> <p>5 Valve
0 Absent
1 VKS - 3 ways valve - 230 V - ON/OFF - complete hydraulic kit
2 KV - 2 ways valve - 230 V - ON/OFF
3 VKMS - 3 ways valve - 24 V - MODULATING - complete hydraulic kit
4 KVM - 2 ways valve - 24 V - MODULATING
5 VKS24 - 3 way valve - 24 V - ON/OFF - complete hydraulic kit
6 KV24 - 2 way valve - 24 V - ON/OFF</p> | <p>6 Control panel
0 Absent
E EVOBOARD - Circuit board
G EVOBOARD circuit board + NAVEL Wi-Fi module</p> <p>7 Probes
0 Absent
1 SA - Remote air probe for MYCOMFORT and EVO
2 SW - Water probe for MYCOMFORT and EVO
3 SU - Humidity probe for MYCOMFORT and EVO
4 SA+SW - Remote air and water probes for MYCOMFORT and EVO
5 SA+SU - Remote air and humidity probes for MYCOMFORT and EVO
6 SA+SU+SW - Remote air, water, humidity probes for MYCOMFORT and EVO
B SA - Remote air probe for TED
C SW - Water probe for TED
D SA + SW - Air and water probes for TED</p> <p>8 Accessories
0 Absent
5 BH - Auxiliary drip tray</p> <p>9 Filter
2 G2 Filter
3 G3 filter</p> <p>10 Release
0 0
A A</p> |
|--|---|

ACCESSORIES

Electronic microprocessor control panels with display

DIST	MYCOMFORT controller spacer for wall mounting
EVO-2-TOUCH	2.8" touch screen user interface for EVO control
EVOBOARD	Circuit board for EVO control
EVO DISP	User interface with display for EVO controller
EYNAVEL	Device for Wi-Fi or Bluetooth communication between EVOBOARD and smartphone
MCBE	MYCOMFORT BASE electronic controller with display
MCLE	Microprocessor control with display MYCOMFORT LARGE
MCSUE	Humidity sensor for MYCOMFORT LARGE and EVO
MCSWE	Water sensor for MYCOMFORT and EVO controllers

Electronic microprocessor control panels

TED 2T	Electronic controller for AC fan control and one ON/OFF 230 V valve
TED 4T	Electronic controller for AC fan control and two ON/OFF 230 V valves
TED SWA	Water temperature sensor for TED controls

Power interface and regulating louver controllers

KP	Power interface for connecting in parallel up to 4 fun coil units to the one controller
-----------	---

Electrical heating elements

RE	Heating element with installation kit, relay box and safety devices
-----------	---

Air inlet and outlet grilles

GA	Aluminium air intake grille, with frame
GM	Aluminium air outlet grille with 2-row fins and subframe

Valves

V2VDF+STD	2-way valves, ON/OFF or MODULATING actuator, 230 V or 24 V power supply, hydraulic kit, for main and additional heat exchanger
V2VSTD	2-way valve, ON/OFF or MODULATING actuator, 230 V or 24 V power supply, hydraulic kit, for main heat exchanger
V3VDF	3-way valves, ON/OFF or MODULATING actuator, 230 V or 24 V power supply, hydraulic kit, for additional heat exchanger

V3VSTD	2-way valves, ON/OFF or MODULATING actuator, 230 V or 24 V power supply, hydraulic kit, for main heat exchanger
---------------	---

VPI	2-way valves pressure independent, ON/OFF actuator, 230 V power supply, hydraulic kit, for main heat exchanger
------------	--

Plenum, air intake modules, air inlet and outlet connectors and cabinets

MAF90	Air intake module with G3 flat air filter
MAF0	Air intake module with G4 undulated air filter
MAF090	Air intake module with G4 flat air filter
PAF	Intake and delivery plenum, not insulated, with spigot Ø 200 mm
PMA	Intake and delivery plenum, not insulated, with spigot Ø 200 mm
PMAC	Intake and delivery plenum, insulated, with spigot Ø 200 mm
R90	90° uninsulated air inlet/outlet connector
R90C	90° uninsulated air inlet/outlet connector
RD	Straight uninsulated air inlet/outlet connector
RDC	Straight insulated air inlet/outlet connector

Flexible ducts - caps

TFA	Not insulated flexible ducts, Ø 200 mm (6 m length indivisible)
TFM	Insulated flexible ducts, Ø 200 mm (6 m length indivisible)
TP	Plastic cap Ø 200 mm

Air inlet and outlet plenum box

CA	Air Inlet plenum box with double row grille
CAF	Air Inlet plenum box with double row grille 300 x 600 mm and filter G2
CM	Insulated air outlet plenum box with grille

Accessories

KSC	Condensate drainage pump kit
VRC	Auxiliary water drip tray

Duct unit DUCTIMAX

RATED TECHNICAL DATA 2 PIPES

DUCTIMAX			13			14			23			24		
Speed			min	med	max	min	med	max	min	med	max	min	med	max
Declared speed			2,5,7			2,5,7			1,5,7			1,5,7		
Rated air flow	(E)	m ³ /h	109	246	276	109	246	276	171	275	341	171	275	341
Available static pressure	(E)	Pa	10	50	63	10	50	63	19	50	77	19	50	77
Power input	(E)	W	24	57	82	24	57	82	34	69	106	34	69	106
Total cooling capacity	(1)(E)	kW	0,92	1,72	1,90	0,95	1,91	2,11	1,27	1,90	2,27	1,36	2,11	2,53
Sensible cooling capacity	(1)(E)	kW	0,61	1,21	1,34	0,63	1,30	1,43	0,89	1,34	1,59	0,93	1,44	1,72
FCEER class	(E)		D											
Water flow	(2)	l/h	160	306	340	167	337	375	222	339	408	239	374	453
Water pressure drop	(2)(E)	kPa	2	5	6	2	7	8	3	6	8	4	8	12
Heating capacity	(3)(E)	kW	0,88	1,81	1,99	0,91	1,98	2,21	1,33	1,98	2,35	1,40	2,20	2,68
FCCOP class	(E)		D											
Water flow	(3)	l/h	153	315	346	158	345	384	231	345	408	244	382	466
Water pressure drop	(3)(E)	kPa	1	4	5	2	6	7	2	5	7	3	7	10
Standard coil - number of rows			3			4			3			4		
Total sound power level	(4)	dB(A)	32	49	29	32	49	52	39	50	54	39	50	54
Inlet + radiated sound power level	(4)(E)	dB(A)	30	47	50	30	47	50	37	48	52	37	48	52
Outlet sound power level	(4)(E)	dB(A)	29	46	49	29	46	49	37	47	51	36	47	51

DUCTIMAX			33			34			43			44		
Speed			min	med	max	min	med	max	min	med	max	min	med	max
Declared speed			1,6,7			1,6,7			1,4,7			1,4,7		
Rated air flow	(E)	m ³ /h	195	360	402	195	360	402	305	532	652	305	532	652
Available static pressure	(E)	Pa	19	50	63	19	50	63	17	50	68	17	50	75
Power input	(E)	W	34	85	106	34	85	106	76	143	192	76	143	192
Total cooling capacity	(1)(E)	kW	1,44	2,28	2,51	1,57	2,69	2,96	1,92	3,17	3,68	2,29	3,78	4,45
Sensible cooling capacity	(1)(E)	kW	1,01	1,69	1,86	1,07	1,86	2,03	1,42	2,39	2,81	1,57	2,61	3,08
FCEER class	(E)		D			D			E			D		
Water flow	(2)	l/h	252	406	449	274	476	527	343	568	664	407	673	798
Water pressure drop	(2)(E)	kPa	2	5	5	3	7	9	3	8	11	6	14	18
Heating capacity	(3)(E)	kW	1,57	2,70	2,96	1,59	2,80	3,10	2,35	3,71	4,31	2,41	3,95	4,68
FCCOP class	(E)		D											
Water flow	(3)	l/h	272	470	515	276	488	538	408	644	749	419	687	814
Water pressure drop	(3)(E)	kPa	2	5	6	2	6	8	4	9	11	5	12	16
Standard coil - number of rows			3			4			3			4		
Total sound power level	(4)	dB(A)	39	50	54	39	50	54	38	52	58	38	52	58
Inlet + radiated sound power level	(4)(E)	dB(A)	37	48	52	37	48	52	36	53	56	36	50	56
Outlet sound power level	(4)(E)	dB(A)	36	47	51	36	47	51	35	49	55	35	49	55

DUCTIMAX			53			54			63			64		
Speed			min	med	max	min	med	max	min	med	max	min	med	max
Declared speed			1,6,7			1,6,7			5,6,7			5,6,7		
Rated air flow	(E)	m ³ /h	333	687	760	333	687	760	1050	1163	1289	1050	1163	1289
Available static pressure	(E)	Pa	12	50	61	12	50	61	40	50	53	40	50	60
Power input	(E)	W	76	167	192	76	167	192	235	280	332	235	280	332
Total cooling capacity	(1)(E)	kW	2,22	4,22	4,63	2,44	4,79	5,23	6,15	6,66	7,21	6,91	7,49	8,12
Sensible cooling capacity	(1)(E)	kW	1,60	3,09	3,39	1,70	3,33	3,64	4,51	4,88	5,29	4,83	5,23	5,67
FCEER class	(E)		D											
Water flow	(2)	l/h	394	753	828	432	850	930	1095	1191	1295	1225	1333	1448
Water pressure drop	(2)(E)	kPa	2	7	8	3	10	12	13	16	18	20	23	26
Heating capacity	(3)(E)	kW	2,54	4,76	5,17	2,63	5,03	5,49	6,68	7,22	7,80	7,18	7,80	8,46
FCCOP class	(E)		D											
Water flow	(3)	l/h	442	827	898	457	875	955	1162	1256	1357	1248	1356	1472
Water pressure drop	(3)(E)	kPa	2	7	8	3	9	11	12	14	16	17	20	23
Standard coil - number of rows			3			4			3			4		
Total sound power level	(4)	dB(A)	38	55	58	38	55	58	61	63	69	61	63	69
Inlet + radiated sound power level	(4)(E)	dB(A)	36	53	56	36	53	56	59	61	67	59	61	67
Outlet sound power level	(4)(E)	dB(A)	35	52	55	35	53	55	58	60	66	58	60	66

(1) Water temperature 7°C/12°C, air temperature dry bulb 27°C, wet bulb 19°C (47% relative humidity) according to EN1397:2021

(2) Water temperature 7°C / 12°C, air temperature dry bulb 27°C, wet bulb 19°C (47% relative humidity)

(3) Water temperature 45°C / 40°C, air temperature 20°C

(4) Sound power measured according to standards ISO 3741 and ISO 3742

(E) EUROVENT certified data

Power supply 230-1-50 (V-ph-Hz)

RATED TECHNICAL DATA 4 PIPES

DUCTIMAX			13			14			23			24		
Speed			min	med	max	min	med	max	min	med	max	min	med	max
Declared speed			2,5,7			2,5,7			1,5,7			1,5,7		
Rated air flow	(E)	m ³ /h	109	243	270	109	243	270	170	272	336	170	272	336
Available static pressure	(E)	Pa	10	50	63	10	50	63	19	50	77	19	50	77
Power input	(E)	W	24	57	82	24	57	82	34	69	106	34	69	106
Total cooling capacity	(1)(E)	kW	0,92	1,70	1,86	0,95	1,88	2,06	1,26	1,88	2,24	1,35	2,09	2,49
Sensible cooling capacity	(1)(E)	kW	0,61	1,20	1,31	0,63	1,28	1,40	0,88	1,33	1,57	0,92	1,42	1,70
FCEER class	(E)		D											
Water flow	(2)	l/h	160	302	333	167	334	368	221	335	404	238	370	447
Water pressure drop	(2)(E)	kPa	2	5	6	2	7	8	3	6	8	4	8	12
Heating capacity	(3)(E)	kW	1,14	1,93	2,06	1,14	1,93	2,06	1,55	2,07	2,32	1,55	2,07	2,32
FCCOP class	(E)		D											
Water flow	(3)	l/h	100	169	180	100	169	180	136	181	204	136	181	204
Water pressure drop	(3)(E)	kPa	1	2	3	1	2	3	2	3	3	2	3	3
Additional coil DF - number of rows			1			1			1			1		
Total sound power level	(4)	dB(A)	32	49	52	32	49	52	39	50	54	39	50	54
Inlet + radiated sound power level	(4)(E)	dB(A)	30	47	50	30	47	50	37	48	52	37	48	52
Outlet sound power level	(4)(E)	dB(A)	29	46	49	29	46	49	36	47	51	36	47	51

DUCTIMAX			33			34			43			44		
Speed			min	med	max	min	med	max	min	med	max	min	med	max
Declared speed			1,6,7			1,6,7			1,4,7			1,4,7		
Rated air flow	(E)	m ³ /h	195	357	398	195	357	398	302	524	642	302	524	642
Available static pressure	(E)	Pa	19	50	63	19	50	63	17	50	75	17	50	75
Power input	(E)	W	34	85	106	34	85	106	76	143	192	76	143	192
Total cooling capacity	(1)(E)	kW	1,44	2,26	2,48	1,57	2,67	2,93	1,89	3,13	3,64	2,27	3,73	4,40
Sensible cooling capacity	(1)(E)	kW	1,01	1,68	1,84	1,07	1,84	2,01	1,41	2,35	2,78	1,56	2,57	3,04
FCEER class	(E)		D			D			E			D		
Water flow	(2)	l/h	252	402	445	274	473	522	339	562	656	403	664	788
Water pressure drop	(2)(E)	kPa	2	5	5	3	7	9	3	8	11	6	13	18
Heating capacity	(3)(E)	kW	2,09	3,09	3,29	2,09	3,09	3,29	2,80	3,82	4,24	2,80	3,82	4,24
FCCOP class	(E)		C			C			D			D		
Water flow	(3)	l/h	183	271	288	183	271	288	245	334	371	245	334	371
Water pressure drop	(3)(E)	kPa	2	3	4	2	3	4	3	5	6	3	5	6
Additional coil DF - number of rows			1			1			1			1		
Total sound power level	(4)	dB(A)	36	47	51	36	47	51	38	52	58	38	52	58
Inlet + radiated sound power level	(4)(E)	dB(A)	37	48	52	37	48	52	36	50	56	36	50	56
Outlet sound power level	(4)(E)	dB(A)	36	47	51	36	47	51	35	49	55	35	49	55

DUCTIMAX			53			54			63			64		
Speed			min	med	max	min	med	max	min	med	max	min	med	max
Declared speed			1,6,7			1,6,7			5,6,7			5,6,7		
Rated air flow	(E)	m ³ /h	333	683	755	333	683	755	1050	1163	1289	1050	1163	1289
Available static pressure	(E)	Pa	12	50	61	12	50	61	40	50	60	40	50	60
Power input	(E)	W	76	167	192	76	167	192	235	280	332	235	280	332
Total cooling capacity	(1)(E)	kW	2,22	4,20	4,60	2,44	4,76	5,20	6,15	6,66	7,21	6,91	7,49	8,12
Sensible cooling capacity	(1)(E)	kW	1,60	3,07	3,36	1,70	3,31	3,62	4,51	4,88	5,29	4,83	5,23	5,67
FCEER class	(E)		D											
Water flow	(2)	l/h	394	749	822	432	846	925	1095	1191	1295	1225	1333	1448
Water pressure drop	(2)(E)	kPa	2	7	8	3	10	12	13	16	18	20	23	26
Heating capacity	(3)(E)	kW	3,40	5,17	5,45	3,40	5,17	5,45	6,42	6,73	7,06	6,42	6,73	7,06
FCCOP class	(E)		D											
Water flow	(3)	l/h	297	452	477	297	452	477	562	590	618	562	590	618
Water pressure drop	(3)(E)	kPa	6	13	14	6	13	14	19	21	22	19	21	22
Additional coil DF - number of rows			1			1			1			1		
Total sound power level	(4)	dB(A)	38	55	58	38	55	58	61	63	69	61	63	69
Inlet + radiated sound power level	(4)(E)	dB(A)	36	53	56	36	53	56	59	61	67	59	61	67
Outlet sound power level	(4)(E)	dB(A)	35	52	55	35	52	55	58	60	66	58	60	66

- (1) Water temperature 7°C/12°C, air temperature dry bulb 27°C, wet bulb 19°C (47% relative humidity) according to EN1397:2021
 - (2) Water temperature 7°C / 12°C, air temperature dry bulb 27°C, wet bulb 19°C
 - (3) Water temperature 65°C / 55°C, air temperature 20°C
 - (4) Sound power measured according to standards ISO 3741 and ISO 3742
 - (E) EUROVENT certified data
- Power supply 230-1-50 (V-ph-Hz)

Duct unit DUCTIMAX

DIMENSIONAL DRAWINGS

DUCTIMAX 1-4

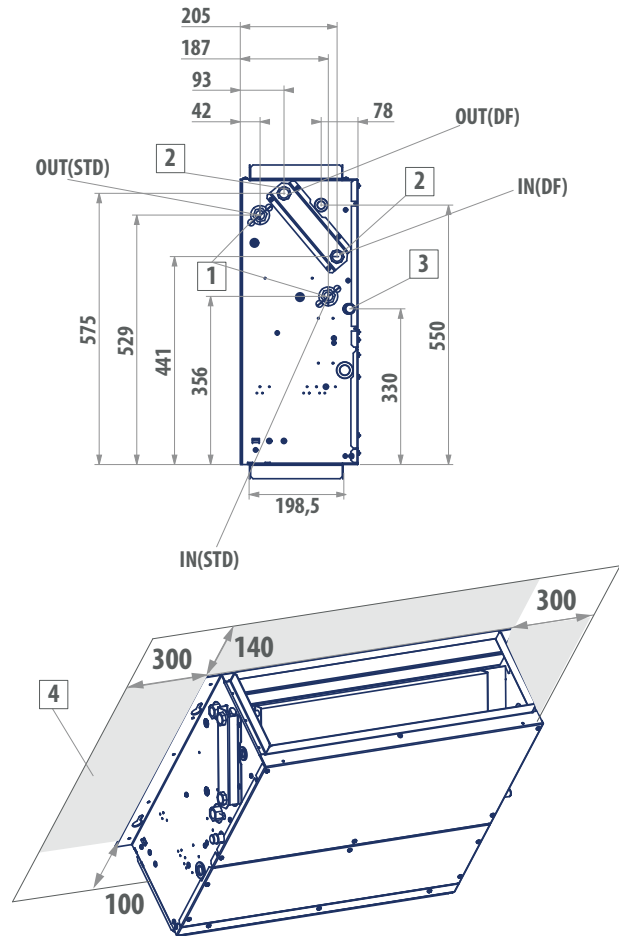
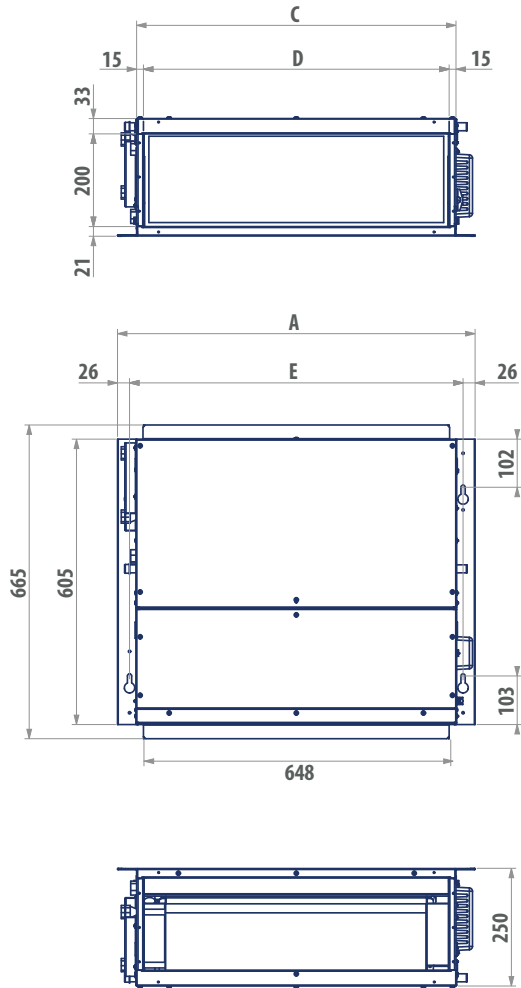

LEGEND

- 1 Water connections standard heat exchanger \varnothing 1/2" female gas
- 2 Water connections additional heat exchanger \varnothing 1/2" female gas
- 3 Condensate discharge

DUCTIMAX	13	14	23	24	33	34	43	44
ON/OFF motor	x	x	x	x	x	x	x	x
Inverter-controlled motor	x	x	x	x	x	x	x	x

x = available

DUCTIMAX	A	C	D	E	1	3	
	mm	mm	mm	mm	"	mm	kg
13 - 14	758	677	648	707	1/2	17	24
23 - 24	758	677	648	707	1/2	17	25
33 - 34	968	887	858	917	1/2	17	33
43 - 44	968	887	858	917	1/2	17	36

DIMENSIONAL DRAWINGS

DUCTIMAX 5-6

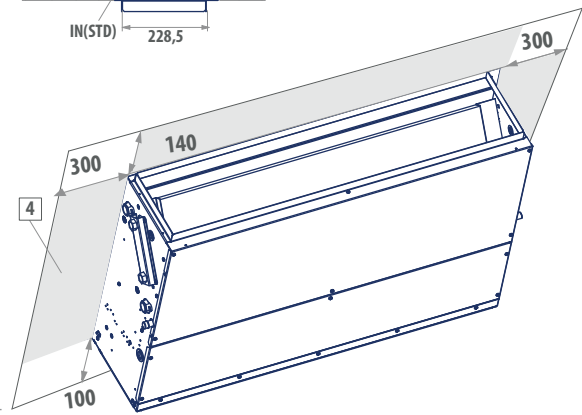
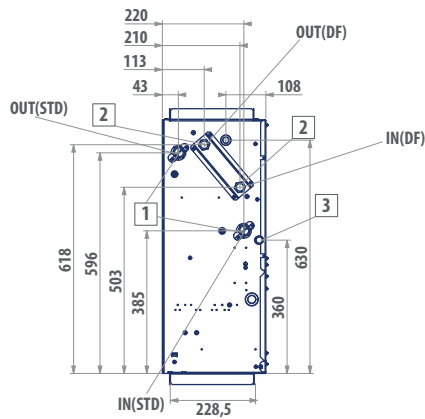
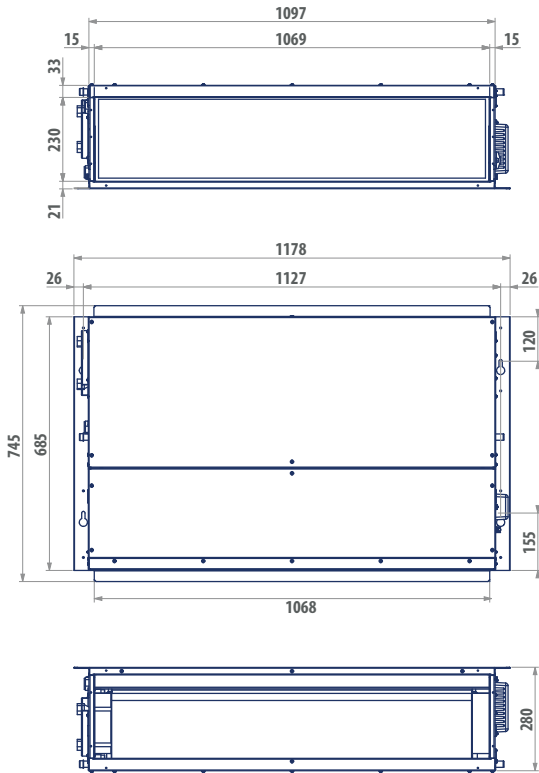

LEGEND

1	Water connections standard heat exchanger ø 3/4" female gas
2	Water connections additional heat exchanger ø 1/2" female gas
3	Condensate discharge

DUCTIMAX	53	54	63	64
ON/OFF motor	x	x	x	x
Inverter-controlled motor	x	x	x	x

x = available

DUCTIMAX	1	2	kg	3
	"	"		mm
53 - 54	3/4	1/2	45	17
63 - 64	3/4	1/2	51	17

Medium available head duct units with EC motor

DUCTIMAX i 2 - 8 kW



Modulation and efficiency in a recess ceiling-mounted unit

The range is completed by DUCTIMAX i, which uses inverter EC technology in the electric motors. To the features of DUCTIMAX it adds the benefits of brushless technology, including a reduction in electricity consumption and consequent reduction in CO₂ emissions, increase in operating flexibility thanks to the modulation of air flow and increase in the level of comfort in terms of temperature, humidity and noise levels.

The range is made up of 12 models with air flows from 300 to 1200 m³/h.

Continuous modulation of the air flow and the use of high-efficiency heat exchangers enables operation also with small air-water temperature differences.

The heat exchangers can also be optimized in the circuit for centralized applications such as district cooling.

Operation is controlled from wall-mounted microprocessor control panels with display, such as the MYCOMFORT LARGE and EVO models.



PLUS

- » Permanent magnet EC motor
- » Low electricity consumption
- » Easy setup of ventilation section
- » Heat exchanger up to 4 rows
- » Compact dimensions
- » Reversible water connections
- » Wide range of available accessories

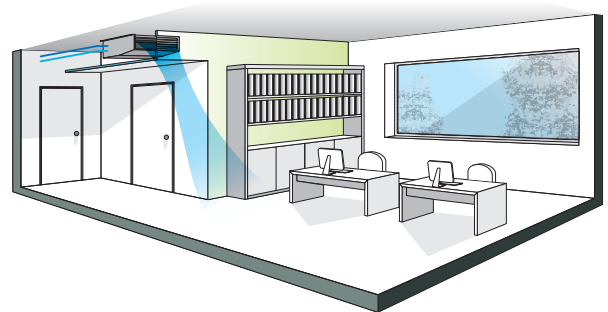

COMPATIBLE WITH PLENUM DMP

Besides assuring a big advantage in terms of energy efficiency, the inverter-controlled EC motor enables flexibility of installation and reduces the time needed to set up the ventilation section, thanks to the continuous modulation of air flow.

AVAILABLE VERSIONS

DMXXDIL0...A Units for 2 pipes systems

DMXXDILL...A Unit for 4-pipe systems equipped with an additional 1-row exchanger for the hot water circuit

DMXXDILM...A Unit for 4-pipe systems equipped with an additional 2-row exchanger for the hot water circuit
(On request)

MAIN COMPONENTS

Structure

Built from galvanised steel sheet, heat and sound insulated by means of Class 1 self-extinguishing panels. Reduced height to facilitate installation in a horizontal position in a false ceiling. The structure incorporates a drip tray and condensate drain outlet.

The main condensate drip tray is situated inside the structure of the unit and is at a positive pressure relative to the drain outlet to facilitate condensate drainage.

Fans

Double suction centrifugal fans made with ABS or aluminium, with statically and dynamically balanced forward-curving blades, directly coupled to the electric motor.

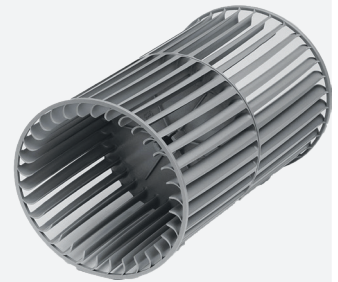

EC electric motor

Permanent magnet motor. The unit is equipped with an inverter board to control the motor, that makes it possible to precisely set the maximum rotation speed of the motor (control signal 0-10 V).

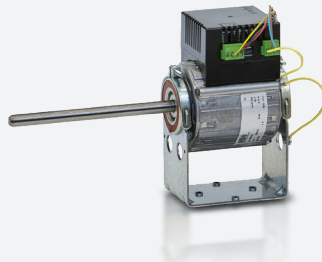

Heat exchanger

High efficiency 3 and 4 rows heat exchanger made with copper piping and aluminium fins blocked to pipings by mechanical expansion, provided with brass manifolds and air vent valve. The heat exchanger usually comes with water connections mounted on the left, but it can be turned by 180°. High-efficiency heat exchangers optimized for district cooling applications are available on request.

Air filter

Washable air filter, made of acrylic fibre, filtration class G2 or G3, applied on the air intake; may be pulled out from below.

ACCESSORIES

Electronic microprocessor control panels with display

DIST	MYCOMFORT controller spacer for wall mounting
EVOBOARD	Circuit board for EVO control
EVODISP	User interface with display for EVO controller
MCLE	Microprocessor control with display MYCOMFORT LARGE
MCSUE	Humidity sensor for MYCOMFORT LARGE and EVO
MCSWE	Water sensor for MYCOMFORT and EVO controllers

Electronic microprocessor control panels

TED 10	Electronic controller for EC fan equipped with inverter and ON/OFF valves 230 V
TED SWA	Water temperature sensor for TED controls

Auxiliary water drip trays, insulating shell, condensate drainage pump

KSC	Condensate drainage pump kit
------------	------------------------------

Electrical heating elements

RE	Heating element with installation kit, relay box and safety devices
-----------	---

Air inlet and outlet grilles

GA	Aluminium air intake grille, with frame
GM	Aluminium air outlet grille with 2-row fins and subframe

Valves

V2VDF+STD	2-way valves, ON/OFF or MODULATING actuator, 230 V or 24 V power supply, hydraulic kit, for main and additional heat exchanger
V2VSTD	2-way valve, ON/OFF or MODULATING actuator, 230 V or 24 V power supply, hydraulic kit, for main heat exchanger
V3VDF	3-way valves, ON/OFF or MODULATING actuator, 230 V or 24 V power supply, hydraulic kit, for additional heat exchanger

V3VSTD	2-way valves, ON/OFF or MODULATING actuator, 230 V or 24 V power supply, hydraulic kit, for main heat exchanger
VPI	2-way valves pressure independent, ON/OFF actuator, 230 V power supply, hydraulic kit, for main heat exchanger

Plenum, air intake modules, air inlet and outlet connectors and cabinets

MAF90	Air intake module with G3 flat air filter
MAF0	Air intake module with G4 undulated air filter
MAF090	Air intake module with G4 flat air filter
PAF	Intake and delivery plenum, not insulated, with spigot Ø 200 mm
PMA	Intake and delivery plenum, not insulated, with spigot Ø 200 mm
PMAC	Intake and delivery plenum, insulated, with spigot Ø 200 mm
R90	90° uninsulated air inlet/outlet connector
R90C	90° uninsulated air inlet/outlet connector
RD	Straight uninsulated air inlet/outlet connector
RDC	Straight insulated air inlet/outlet connector

Flexible ducts - caps

TFA	Not insulated flexible ducts, Ø 200 mm (6 m length indivisible)
TFM	Insulated flexible ducts, Ø 200 mm (6 m length indivisible)
TP	Plastic cap Ø 200 mm

Air inlet and outlet plenum box

CA	Air Inlet plenum box with double row grille
CAF	Air Inlet plenum box with double row grille 300 x 600 mm and filter G2
CM	Insulated air outlet plenum box with grille

Accessories

VRC	Auxiliary water drip tray
------------	---------------------------

Duct unit DUCTIMAX i

RATED TECHNICAL DATA 2 PIPES

DUCTIMAX i			13			14			23			24		
Speed			min	med	max	min	med	max	min	med	max	min	med	max
Control voltage	(E)	V	2,90	8,00	9,00	2,90	8,00	9,00	4,30	7,50	8,40	4,30	7,50	8,40
Rated air flow	(E)	m ³ /h	48	246	276	109	246	276	171	275	341	171	275	341
Available static pressure	(E)	Pa	3	50	63	10	50	63	19	50	77	19	50	77
Power input	(E)	W	6	25	33	6	25	33	10	24	39	10	24	39
Total cooling capacity	(1)(E)	kW	0,93	1,76	1,95	0,96	1,92	2,16	1,29	1,95	2,34	1,38	2,16	2,60
Sensible cooling capacity	(1)(E)	kW	0,62	1,25	1,39	0,64	1,34	1,48	0,91	1,39	1,66	0,95	1,49	1,79
FCEER class	(E)		A											
Water flow	(2)	l/h	161	306	340	167	337	375	222	339	408	239	374	453
Water pressure drop	(2)(E)	kPa	2	5	6	2	7	8	3	6	8	4	8	12
Heating capacity	(3)(E)	kW	0,88	1,81	1,99	0,91	1,98	2,21	1,33	1,98	2,35	1,40	2,20	2,68
FCCOP class	(E)		A											
Water flow	(3)	l/h	153	315	346	158	345	384	231	345	408	244	382	466
Water pressure drop	(3)(E)	kPa	1	4	5	2	6	7	2	5	7	3	7	10
Standard coil - number of rows			3			4			3			4		
Total sound power level	(4)	dB(A)	32	51	52	32	49	52	39	50	54	39	50	54
Inlet + radiated sound power level	(4)(E)	dB(A)	30	50	50	30	47	50	37	48	52	37	48	52
Outlet sound power level	(4)(E)	dB(A)	29	46	49	29	46	49	36	47	51	36	47	51

DUCTIMAX i			33			34			43			44		
Speed			min	med	max	min	med	max	min	med	max	min	med	max
Control voltage	(E)	V	4,50	7,40	8,30	4,50	7,40	8,30	5,40	8,30	9,90	5,40	8,30	9,90
Rated air flow	(E)	m ³ /h	195	360	402	195	360	402	305	532	652	235	451	570
Available static pressure	(E)	Pa	19	50	63	19	50	63	17	50	75	17	50	75
Power input	(E)	W	10	26	35	10	26	35	22	51	77	22	51	77
Total cooling capacity	(1)(E)	kW	1,46	2,33	2,59	1,59	2,74	3,04	1,98	3,26	3,79	2,35	3,87	4,56
Sensible cooling capacity	(1)(E)	kW	1,03	1,74	1,94	1,09	1,91	2,11	1,48	2,48	2,92	1,63	2,70	3,19
FCEER class	(E)		A			A			B			A		
Water flow	(2)	l/h	252	406	449	274	476	527	343	568	664	407	673	798
Water pressure drop	(2)(E)	kPa	2	5	5	3	7	9	3	8	11	6	14	18
Heating capacity	(3)(E)	kW	1,57	2,70	2,96	1,59	2,80	3,10	2,35	3,71	4,31	2,41	3,95	4,68
FCCOP class	(E)		A											
Water flow	(3)	l/h	272	470	515	276	488	538	408	644	749	419	687	814
Water pressure drop	(3)(E)	kPa	2	5	6	2	6	8	4	9	11	5	12	16
Standard coil - number of rows			3			4			3			4		
Total sound power level	(4)	dB(A)	39	50	54	39	50	54	38	52	58	38	52	58
Inlet + radiated sound power level	(4)(E)	dB(A)	37	48	52	37	48	52	36	50	56	36	50	56
Outlet sound power level	(4)(E)	dB(A)	36	47	51	36	47	51	35	49	55	35	49	55

(1) Water temperature 7°C/12°C, air temperature dry bulb 27°C, wet bulb 19°C (47% relative humidity) according to EN1397:2021

(2) Water temperature 7°C / 12°C, air temperature dry bulb 27°C, wet bulb 19°C (47% relative humidity)

(3) Water temperature 45°C / 40°C, air temperature 20°C

(4) Sound power measured according to standards ISO 3741 and ISO 3742

(E) EUROVENT certified data

Power supply 230-1-50 (V-ph-Hz)

NOTE: The dimensional drawings of the DUCTIMAX i inverter units are the same of the DUCTIMAX ON/OFF version. They are reported from page 110

RATED TECHNICAL DATA 2 PIPES

DUCTIMAX i			53			54			63			64		
Speed			min	med	max	min	med	max	min	med	max	min	med	max
Control voltage	(E)	V	3,40	7,60	8,50	3,40	7,60	8,50	6,80	7,50	8,30	6,80	7,50	8,30
Rated air flow	(E)	m ³ /h	333	687	760	333	687	760	1050	1163	1289	1050	1163	1289
Available static pressure	(E)	Pa	12	50	61	12	50	61	40	50	60	40	50	60
Power input	(E)	W	11	54	67	11	54	67	105	128	162	105	128	162
Total cooling capacity	(1)(E)	kW	2,29	4,34	4,75	2,51	4,91	5,35	6,28	6,81	7,38	7,04	7,64	8,28
Sensible cooling capacity	(1)(E)	kW	1,67	3,21	3,51	1,77	3,45	3,76	4,64	5,03	5,46	4,96	5,38	5,84
FCEER class	(E)		A			A			C			B		
Water flow	(2)	l/h	394	753	828	432	850	930	1094	1190	1295	1225	1332	1448
Water pressure drop	(2)(E)	kPa	2	7	8	3	10	12	13	16	18	20	23	26
Heating capacity	(3)(E)	kW	2,54	4,74	5,17	2,63	5,03	5,49	6,68	7,22	7,80	7,18	7,80	8,46
FCCOP class	(E)		A			A			B			B		
Water flow	(3)	l/h	441	827	898	457	875	955	1162	1256	1356	1248	1355	1471
Water pressure drop	(3)(E)	kPa	2	7	8	3	9	11	12	14	16	17	19	22
Standard coil - number of rows			3			4			3			4		
Total sound power level	(4)	dB(A)	38	55	58	38	55	58	61	63	69	61	63	69
Inlet + radiated sound power level	(4)(E)	dB(A)	36	53	56	36	53	56	59	61	67	59	61	67
Outlet sound power level	(4)(E)	dB(A)	35	52	55	35	52	55	58	60	66	58	60	66

(1) Water temperature 7°C/12°C, air temperature dry bulb 27°C, wet bulb 19°C (47% relative humidity) according to EN1397:2021

(2) Water temperature 7°C / 12°C, air temperature dry bulb 27°C, wet bulb 19°C (47% relative humidity)

(3) Water temperature 45°C / 40°C, air temperature 20°C

(4) Sound power measured according to standards ISO 3741 and ISO 3742

(E) EUROVENT certified data

Power supply 230-1-50 (V-ph-Hz)

NOTE: The dimensional drawings of the DUCTIMAX i inverter units are the same of the DUCTIMAX ON/OFF version. They are reported from page 110

Duct unit DUCTIMAX i

RATED TECHNICAL DATA 4 PIPES

DUCTIMAX i			13			14			23			24		
Speed			min	med	max	min	med	max	min	med	max	min	med	max
Control voltage	(E)	V	2,90	7,90	8,90	2,90	7,90	8,90	4,50	7,30	8,90	4,50	7,30	8,90
Rated air flow	(E)	m ³ /h	109	243	270	109	243	270	170	272	336	170	272	336
Available static pressure	(E)	Pa	10	50	63	10	50	63	19	50	77	19	50	77
Power input	(E)	W	6	25	32	6	25	32	10	23	39	10	23	39
Total cooling capacity	(1)(E)	kW	0,93	1,74	1,91	0,96	1,92	2,11	1,28	1,93	2,31	1,37	2,14	2,56
Sensible cooling capacity	(1)(E)	kW	0,62	1,24	1,36	0,64	1,32	1,45	0,90	1,38	1,64	0,94	1,47	1,77
FCEER class	(E)		A											
Water flow	(2)	l/h	161	302	333	167	334	368	221	335	404	238	370	447
Water pressure drop	(2)(E)	kPa	2	5	6	2	7	8	3	6	8	4	8	12
Heating capacity	(3)(E)	kW	1,14	1,93	2,06	1,14	1,93	2,06	1,55	2,07	2,32	1,55	2,07	2,32
FCCOP class	(E)		A											
Water flow	(3)	l/h	100	169	180	100	169	180	136	181	204	136	181	204
Water pressure drop	(3)(E)	kPa	1	2	3	1	2	3	2	3	3	2	3	3
Additional coil DF - number of rows			3+1			4+1			3+1			4+1		
Total sound power level	(4)	dB(A)	32	49	52	32	49	52	41	53	56	39	50	54
Inlet + radiated sound power level	(4)(E)	dB(A)	30	47	50	30	47	50	40	52	55	37	48	52
Outlet sound power level	(4)(E)	dB(A)	29	46	49	29	46	49	36	47	51	36	47	51

DUCTIMAX i			33			34			43			44		
Speed			min	med	max	min	med	max	min	med	max	min	med	max
Control voltage	(E)	V	4,50	7,40	8,30	4,50	7,40	8,30	5,40	8,30	9,90	5,40	8,30	9,90
Rated air flow	(E)	m ³ /h	195	357	398	195	357	398	302	524	642	302	524	642
Available static pressure	(E)	Pa	19	50	63	19	50	63	17	50	75	17	50	75
Power input	(E)	W	10	26	35	10	26	35	21	50	77	21	50	77
Total cooling capacity	(1)(E)	kW	1,46	2,31	2,56	1,59	2,72	3,01	1,95	3,22	3,75	2,33	3,82	4,51
Sensible cooling capacity	(1)(E)	kW	1,03	1,73	1,92	1,09	1,89	2,09	1,47	2,44	2,89	1,62	2,66	3,15
FCEER class	(E)		A			A			B			A		
Water flow	(2)	l/h	252	402	445	274	473	522	339	562	656	403	664	788
Water pressure drop	(2)(E)	kPa	2	5	5	3	7	9	3	8	11	6	13	18
Heating capacity	(3)(E)	kW	1,71	2,53	2,69	1,69	2,50	2,66	2,80	3,82	4,24	2,80	3,82	4,24
FCCOP class	(E)		A											
Water flow	(3)	l/h	183	271	288	183	271	288	245	334	371	245	334	371
Water pressure drop	(3)(E)	kPa	3	4	5	4	5	7	3	5	6	3	5	6
Additional coil DF - number of rows			3+1			4+1			3+1			4+1		
Total sound power level	(4)	dB(A)	39	50	54	39	50	54	38	52	58	38	52	58
Inlet + radiated sound power level	(4)(E)	dB(A)	37	48	52	37	48	52	36	50	56	36	50	56
Outlet sound power level	(4)(E)	dB(A)	36	47	51	36	47	51	35	49	55	35	49	55

(1) Water temperature 7°C/12°C, air temperature dry bulb 27°C, wet bulb 19°C (47% relative humidity) according to EN1397:2021

(2) Water temperature 7°C / 12°C, air temperature dry bulb 27°C, wet bulb 19°C (47% relative humidity)

(3) Water temperature 65°C / 55°C, air temperature 20°C

(4) Sound power measured according to standards ISO 3741 and ISO 3742

(E) EUROVENT certified data

Power supply 230-1-50 (V-ph-Hz)

NOTE: The dimensional drawings of the DUCTIMAX i inverter units are the same of the DUCTIMAX ON/OFF version. They are reported from page 110

RATED TECHNICAL DATA 4 PIPES

DUCTIMAX i			53			54			63			64		
Speed			min	med	max	min	med	max	min	med	max	min	med	max
Control voltage	(E)	V	3,40	7,60	8,50	3,40	7,60	8,50	6,80	7,50	8,30	6,80	7,50	8,30
Rated air flow	(E)	m ³ /h	333	683	755	333	683	755	1050	1163	1289	1060	1163	1289
Available static pressure	(E)	Pa	12	50	61	12	50	61	40	50	60	40	50	60
Power input	(E)	W	11	54	67	11	54	67	149	204	244	105	128	191
Total cooling capacity	(1)(E)	kW	2,29	4,32	4,72	2,51	4,88	5,32	6,28	6,81	7,38	7,04	7,64	8,28
Sensible cooling capacity	(1)(E)	kW	1,67	3,19	3,48	1,77	3,43	3,74	4,64	5,03	5,46	4,96	5,38	5,84
FCEER class	(E)		A			A			C			B		
Water flow	(2)	l/h	394	749	822	432	846	925	1094	1190	1295	1225	1332	1448
Water pressure drop	(2)(E)	kPa	2	7	8	3	10	12	13	16	18	20	23	26
Heating capacity	(3)(E)	kW	3,40	5,17	5,45	3,40	5,17	5,45	6,42	6,73	7,06	6,42	6,73	7,06
FCCOP class	(E)		A			A			D			C		
Water flow	(3)	l/h	297	452	477	297	452	477	562	589	618	562	589	618
Water pressure drop	(3)(E)	kPa	6	13	14	6	13	14	19	21	22	19	21	22
Additional coil DF - number of rows			3+1			4+1			3+1			4+1		
Total sound power level	(4)	dB(A)	38	55	58	38	55	58	61	63	69	61	63	69
Inlet + radiated sound power level	(4)(E)	dB(A)	36	53	56	36	53	56	59	61	67	59	61	67
Outlet sound power level	(4)(E)	dB(A)	35	52	55	35	52	55	61	64	66	58	60	66

- (1) Water temperature 7°C/12°C, air temperature dry bulb 27°C, wet bulb 19°C (47% relative humidity) according to EN1397:2021
(2) Water temperature 7°C / 12°C, air temperature dry bulb 27°C, wet bulb 19°C (47% relative humidity)
(3) Water temperature 65°C / 55°C, air temperature 20°C
(4) Sound power measured according to standards ISO 3741 and ISO 3742
(E) EUROVENT certified data
Power supply 230-1-50 (V-ph-Hz)

NOTE: The dimensional drawings of the DUCTIMAX i inverter units are the same of the DUCTIMAX ON/OFF version. They are reported from page 110

High-head thermal ventilating units

UTN 3 - 23 kW



Flexibility of installation to respond to every need

The UTN range of thermal ventilating units has been developed for air conditioning rooms where the use of ducted hydronic indoor units capable of assuring available heads of up to 180 Pa and cooling capacities of 3 to 23 kW is required. The units are characterised by a high flexibility of installation, as they can in fact be positioned either vertically or horizontally and the orientation of the air intake in the rear or front part of the unit itself can be modified by simply moving the inspection panel. All units have a standard configuration for the intake of fresh air and slots for rapidly fixing them to the wall or ceiling. Their reduced height (280 mm up to size 16 and 350 mm for larger sizes) enables them to be accommodated in normal false ceiling and the availability of a wide range of plumbing and ventilation accessories makes it easy to integrate them into air conditioning systems. The units are available in standard and high-efficiency models, depending on the finned block exchanger used, so that they can be better adapted to the needs of the room to be air-conditioned.

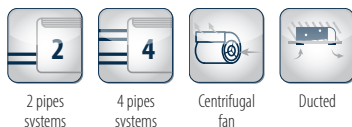

PLUS

- » Compact dimensions (height 280 mm up to size 16 and 350 mm for larger sizes)
- » Vertical and horizontal installation
- » Wide range of available accessories for simple integration into the system
- » Available head up to 180 Pa
- » High flexibility of installation

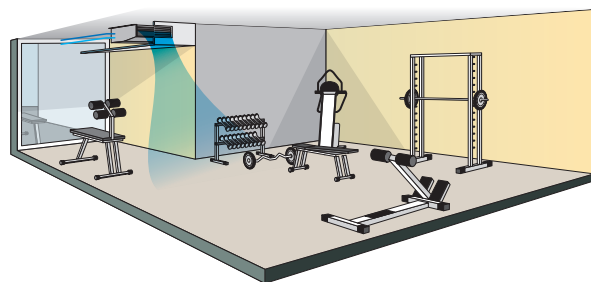

AVAILABLE VERSIONS

UTXXX0L0...0A

Thermal ventilating unit suitable for 2-pipe systems

UTXXX0LL...0A

Thermal ventilating unit suitable for 4-pipe systems (2 heat exchangers)

UTXXX0L0...02

The version with double panelling is made with pre-painted sheet steel insulated with class 0 fire-resistant rockwool **(On request)**

MAIN COMPONENTS

Structure

Made of galvanized sheet steel insulated with sound-deadening, heat-insulating, self-extinguishing closed-cell material to reduce noise emissions and prevent the formation of condensate on the outside surface.

Heat exchanger

It is composed of copper tubing and aluminium fins fixed by expansion.
Water connections are reversible
An additional exchanger is available for installing the unit in 4-pipe systems.

Fan

The aluminium fans are of the centrifugal type, with double suction and staggered blades to reduce noise emissions. They are statically and dynamically balanced to minimize the stresses transmitted to the motor shaft.



Filter module

The air filter, made of regenerable acrylic fibre, is available as an accessory in filtration classes G2 or G4.

Electric motor

Three-speed electrical motor, mounted on vibration damping couplings, directly connected to the fans, with permanently activated capacitor and winding thermal protection.

Condensate collection and drainage system

It consists of two insulated galvanized sheet steel trays designed for horizontal and vertical installation.

CONFIGURATOR

The models are completely configurable by selecting the version and the options. To the right is shown an example of configuration.

Version	Field	1	2	3	4	5	6	7	8	9	10	11
UT08		D	0	L	0	0	0	0	0	N	0	A

To verify the compatibility of the options, use the selection software or the price list.

CONFIGURATOR

1 Version

- A Ducted version with high performance
- D Standard ducted version

2 Motor

- 0 3-speed motor
- I BLDC motor

3 Main coil hydraulic side

- L Water connections on the left side
- R Water connections on the right

4 Additional coil hydraulic side / heating element

- 0 Absent
- L Water connections on the left side
- R Water connections on the right

5 Valve

- 0 Absent

6 Control panel

- 0 Absent
- E EVOBOARD - Circuit board
- G EVOBOARD circuit board + NAVEI Wi-Fi module

7 Probes

- 0 Absent
- 1 SA - Remote air probe for MYCOMFORT and EVO
- 2 SW - Water probe for MYCOMFORT and EVO
- 3 SU - Humidity probe for MYCOMFORT and EVO
- 4 SA+SW - Remote air and water probes for MYCOMFORT and EVO
- 5 SA+SU - Remote air and humidity probes for MYCOMFORT and EVO
- 6 SA+SU+SW - Remote air, water, humidity probes for MYCOMFORT and EVO
- B SA - Remote air probe for TED
- C SW - Water probe for TED
- D SA + SW - Air and water probes for TED

8 Accessories

- 0 Absent

9 Filter

- N No filter

10 Release

- 0 0
- A A

ACCESSORIES

Electromechanical control panels

IPM Circuit board for connection of UTN 30-30A-40-40A to control panels.

TA2 Electromechanical room thermostat with summer/winter selection

Electronic microprocessor control panels with display

DIST MYCOMFORT controller spacer for wall mounting

EVO-2-TOUCH 2.8" touch screen user interface for EVO control

EVOBOARD Circuit board for EVO control

EVO DISP User interface with display for EVO controller

EYNAVEL Device for Wi-Fi or Bluetooth communication between EVOBOARD and smartphone

MCBE MYCOMFORT BASE electronic controller with display

MCLE Microprocessor control with display MYCOMFORT LARGE

MCSUE Humidity sensor for MYCOMFORT LARGE and EVO

MCSWE Water sensor for MYCOMFORT and EVO controllers

Electronic microprocessor control panels

TED 2T Electronic controller for AC fan control and one ON/OFF 230 V valve

TED 4T Electronic controller for AC fan control and two ON/OFF 230 V valves

TED SWA Water temperature sensor for TED controls

Power interface and regulating louver controllers

CSD Recess mounted controller for opening and closing the SM motor-driven regulating louver

KP Power interface for connecting in parallel up to 4 fan coil units to the one controller

Auxiliary water drip trays, insulating shell, condensate drainage pump

KSC Condensate drainage pump kit

Electrical heating elements

RE Heating element with installation kit, relay box and safety devices

Air inlet and outlet grilles

GA Aluminium air intake grille, with frame

GM Aluminium air outlet grille with 2-row fins and subframe

GR Air intake grille with subframe

GRF Air intake grille with subframe and filter

External air intake louvers

PA90 Motor-driven external air intake louver

Valves

V2VDF+STD 2-way valves, ON/OFF or MODULATING actuator, 230 V or 24 V power supply, hydraulic kit, for main and additional heat exchanger

V2VSTD 2-way valve, ON/OFF or MODULATING actuator, 230 V or 24 V power supply, hydraulic kit, for main heat exchanger

V3VDF 3-way valves, ON/OFF or MODULATING actuator, 230 V or 24 V power supply, hydraulic kit, for additional heat exchanger

V3VSTD 2-way valves, ON/OFF or MODULATING actuator, 230 V or 24 V power supply, hydraulic kit, for main heat exchanger

VPIC 2-way valves pressure independent, ON/OFF actuator, 230 V power supply, hydraulic kit, for main heat exchanger

Plenum, air intake modules, air inlet and outlet connectors and cabinets

G90 90° connection for intake/delivery

MAF Air intake module with G2 flat air filter

MAFO Air intake module with G4 undulated air filter

PCOC Junction panel with rectangular duct

PCOF Junction panel with flexible circular duct Ø 200

Flexible ducts - caps

TFA Not insulated flexible ducts, Ø 200 mm (6 m length indivisible)

TFM Insulated flexible ducts, Ø 200 mm (6 m length indivisible)

TP Plastic cap Ø 200 mm

Air inlet and outlet plenum box

CA Air Inlet plenum box with double row grille

CAF Air Inlet plenum box with double row grille 300 x 600 mm and filter G2

CM Insulated air outlet plenum box with grille

Accessories

UYBP Hot water post-heating exchanger kit

VRCH Auxiliary water drip tray for horizontal installation units

VRCV Auxiliary water drip tray for vertical installation units

RATED TECHNICAL DATA 2 PIPES

UTN			6A			6D			8A			8D		
Speed			min	med	max	min	med	max	min	med	max	min	med	max
Rated air flow	(E)	m ³ /h	343	458	561	348	465	572	532	692	791	534	700	802
Available static pressure	(E)	Pa	28	50	75	28	50	75	30	50	65	29	50	65
Power input	(E)	W	84	122	188	84	122	188	135	185	265	135	185	265
Total cooling capacity	(1)(E)	kW	2,22	2,88	3,39	1,94	2,46	2,84	3,29	4,09	4,50	2,74	3,36	3,65
Sensible cooling capacity	(1)(E)	kW	1,63	2,13	2,52	1,47	1,87	2,16	2,45	3,08	3,41	2,10	2,59	2,83
FCEER class	(E)		E											
Water flow	(2)	l/h	382	496	584	334	424	489	567	704	775	472	579	629
Water pressure drop	(2)(E)	kPa	4	6	9	5	8	11	8	12	14	10	14	17
Heating capacity	(3)(E)	kW	2,47	3,14	3,70	2,19	2,75	3,20	3,55	4,36	4,83	3,04	3,69	4,05
FCCOP class	(E)		D			E			E			E		
Water flow	(3)	l/h	425	541	637	377	474	551	611	751	832	523	635	697
Water pressure drop	(3)(E)	kPa	4	6	8	5	8	10	7	11	13	9	13	15
Standard coil - number of rows			4			3			4			3		
Total sound power level	(4)	dB(A)	48	57	63	48	57	63	54	61	66	54	61	66
Inlet + radiated sound power level	(4)(E)	dB(A)	46	54	61	46	54	61	52	59	64	52	59	64
Outlet sound power level	(4)(E)	dB(A)	45	53	59	45	53	59	51	58	63	51	58	63

UTN			12A			12D			16A			16D		
Speed			min	med	max	min	med	max	min	med	max	min	med	max
Rated air flow	(E)	m ³ /h	1000	1107	1203	1019	1134	1238	1198	1371	1581	1207	1384	1606
Available static pressure	(E)	Pa	41	50	59	40	50	59	38	50	66	38	50	67
Power input	(E)	W	345	385	460	345	385	460	290	380	505	290	380	505
Total cooling capacity	(1)(E)	kW	5,54	5,99	6,34	4,98	5,39	5,70	6,67	7,41	8,24	6,03	6,63	7,32
Sensible cooling capacity	(1)(E)	kW	4,11	4,47	4,73	3,66	3,94	4,16	5,23	5,86	6,58	4,84	5,39	6,04
FCEER class	(E)		E											
Water flow	(2)	l/h	954	1031	1092	858	928	982	1149	1276	1419	1038	1142	1261
Water pressure drop	(2)(E)	kPa	15	17	19	18	21	24	11	13	16	17	20	24
Heating capacity	(3)(E)	kW	6,29	6,80	7,26	5,59	6,03	6,42	7,28	8,04	8,93	6,47	7,11	7,88
FCCOP class	(E)		E											
Water flow	(3)	l/h	1083	1171	1250	963	1038	1106	1254	1384	1538	1114	1224	1357
Water pressure drop	(3)(E)	kPa	14	17	18	17	19	22	10	12	14	15	17	21
Standard coil - number of rows			4			3			4			3		
Total sound power level	(4)	dB(A)	61	63	69	59	63	69	62	67	72	62	67	72
Inlet + radiated sound power level	(4)(E)	dB(A)	56	60	66	56	60	66	60	64	70	60	64	70
Outlet sound power level	(4)(E)	dB(A)	59	59	65	55	59	65	58	63	69	58	63	69

(1) Water temperature 7°C/12°C, air temperature dry bulb 27°C, wet bulb 19°C (47% relative humidity) according to EN1397:2021

(2) Water temperature 7°C / 12°C, air temperature dry bulb 27°C, wet bulb 19°C (47% relative humidity)

(3) Water temperature 45°C / 40°C, air temperature 20°C

(4) Sound power measured according to standards ISO 3741 and ISO 3742

(E) EUROVENT certified data

Power supply 230-1-50 (V-ph-Hz)

RATED TECHNICAL DATA 2 PIPES

UTN			19A			22A			22D			30A		
Speed			min	med	max	min	med	max	min	med	max	min	med	max
Rated air flow	(E)	m ³ /h	1166	1500	1577	1436	1819	2222	1483	1898	2376	2074	2604	3174
Available static pressure	(E)	Pa	38	50	62	31	50	75	30	50	78	32	50	74
Power input	(E)	W	290	380	505	370	535	750	370	535	750	870	1090	1300
Total cooling capacity	(1)(E)	kW	7,34	9,17	10,1	9,20	11,2	13,1	8,41	10,1	11,8	12,9	15,4	17,7
Sensible cooling capacity	(1)(E)	kW	5,43	6,81	8,83	6,76	8,32	9,85	6,35	7,75	9,22	9,38	11,4	13,5
FCEER class	(E)		E											
Water flow	(2)	l/h	1266	1582	1749	1584	1927	2249	1448	1743	2039	2221	2652	3048
Water pressure drop	(2)(E)	kPa	20	31	36	12	17	22	15	21	29	27	37	48
Heating capacity	(3)(E)	kW	7,94	9,96	11,0	9,73	11,7	13,7	9,06	10,8	12,7	13,7	16,4	19,1
FCCOP class	(E)		D			E			E			E		
Water flow	(3)	l/h	1365	1715	1857	1676	2020	2354	1560	1867	2190	2359	2824	3289
Water pressure drop	(3)(E)	kPa	22	29	34	10	14	19	14	19	25	23	32	41
Standard coil - number of rows			4			4			3			5		
Total sound power level	(4)	dB(A)	61	67	71	60	67	74	60	67	74	69	73	78
Inlet + radiated sound power level	(4)(E)	dB(A)	59	65	69	58	65	72	58	65	72	67	71	76
Outlet sound power level	(4)(E)	dB(A)	57	63	68	57	64	71	57	64	71	66	70	75

UTN			30D			40A			40D		
Speed			min	med	max	min	med	max	min	med	max
Rated air flow	(E)	m ³ /h	2092	2641	3207	3067	3622	4287	3129	3706	4422
Available static pressure	(E)	Pa	31	50	74	36	50	71	35	50	71
Power input	(E)	W	870	1090	1300	650	820	1150	650	820	1150
Total cooling capacity	(1)(E)	kW	11,6	13,8	15,9	17,3	19,6	22,0	15,4	17,4	19,5
Sensible cooling capacity	(1)(E)	kW	8,61	10,4	12,2	13,3	15,3	17,5	12,1	13,8	15,6
FCEER class	(E)		E			D			E		
Water flow	(2)	l/h	2003	2382	2741	3082	3505	3979	2761	3128	3551
Water pressure drop	(2)(E)	kPa	21	29	37	16	20	25	17	21	26
Heating capacity	(3)(E)	kW	12,7	15,0	17,3	18,8	21,2	24,0	17,2	19,4	21,8
FCCOP class	(E)		E			D			D		
Water flow	(3)	l/h	2183	2592	2977	3263	3693	4177	2986	3364	3799
Water pressure drop	(3)(E)	kPa	18	25	31	18	22	28	18	23	28
Standard coil - number of rows			4			5			4		
Total sound power level	(4)	dB(A)	69	73	78	70	74	79	70	74	79
Inlet + radiated sound power level	(4)(E)	dB(A)	67	71	76	68	72	77	68	72	77
Outlet sound power level	(4)(E)	dB(A)	66	70	75	67	71	76	67	71	76

(1) Water temperature 7°C/12°C, air temperature dry bulb 27°C, wet bulb 19°C (47% relative humidity) according to EN1397:2021

(2) Water temperature 7°C / 12°C, air temperature dry bulb 27°C, wet bulb 19°C (47% relative humidity)

(3) Water temperature 45°C / 40°C, air temperature 20°C

(4) Sound power measured according to standards ISO 3741 and ISO 3742

(E) EUROVENT certified data

Power supply 230-1-50 (V-ph-Hz)

RATED TECHNICAL DATA 4 PIPES

UTN			6A			6D			8A			8D		
Speed			min	med	max	min	med	max	min	med	max	min	med	max
Rated air flow DF	(E)	m ³ /h	342	455	557	346	463	567	529	686	783	531	694	793
Available static pressure DF	(E)	Pa	28	50	75	28	50	75	30	50	65	29	50	65
Power input DF	(E)	W	84	122	188	84	122	188	135	185	265	135	185	265
Total cooling capacity DF	(1)(E)	kW	2,21	2,86	3,37	1,93	2,44	2,82	3,27	4,06	4,46	2,73	3,33	3,61
Sensible cooling capacity DF	(1)(E)	kW	1,62	2,11	2,50	1,46	1,86	2,15	2,43	3,06	3,38	2,09	2,57	2,80
FCEER class DF	(E)		E											
Water flow DF	(2)	l/h	381	492	580	332	420	486	563	699	768	470	573	622
Water pressure drop DF	(2)(E)	kPa	4	6	9	5	8	11	8	12	14	10	14	17
Heating capacity DF	(3)(E)	kW	2,56	2,99	3,31	2,58	3,02	3,34	3,23	3,66	3,89	3,23	3,68	3,91
FCCOP class DF	(E)		D			D			E			E		
Water flow DF	(3)	l/h	220	257	285	222	260	288	278	315	335	278	317	337
Water pressure drop DF	(3)(E)	kPa	3	4	5	3	5	5	5	6	7	5	6	7
Additional coil DF - number of rows			1			1			1			1		
Total sound power level DF	(4)	dB(A)	48	57	63	48	57	63	54	61	66	54	61	66
Inlet + radiated sound power level DF	(4)(E)	dB(A)	46	54	61	46	54	61	52	59	64	52	59	64
Outlet sound power level DF	(4)(E)	dB(A)	45	53	59	45	53	59	51	58	63	51	58	63

UTN			12A			12D			16A			16D		
Speed			min	med	max	min	med	max	min	med	max	min	med	max
Rated air flow DF	(E)	m ³ /h	985	1088	1182	1005	1115	1211	1184	1349	1550	1192	1362	1576
Available static pressure DF	(E)	Pa	41	50	59	41	50	59	38	50	66	38	50	67
Power input DF	(E)	W	345	385	460	345	385	460	290	380	505	290	380	505
Total cooling capacity DF	(1)(E)	kW	5,47	5,91	6,24	4,93	5,32	5,60	6,60	7,31	8,10	5,97	6,54	7,21
Sensible cooling capacity DF	(1)(E)	kW	4,06	4,40	4,66	3,60	3,89	4,08	5,17	5,77	6,46	4,79	5,31	5,94
FCEER class DF	(E)		E											
Water flow DF	(2)	l/h	942	1018	1075	849	916	964	1137	1259	1395	1028	1126	1242
Water pressure drop DF	(2)(E)	kPa	15	17	19	18	21	23	10	13	15	16	19	23
Heating capacity DF	(3)(E)	kW	5,21	5,45	5,65	5,25	5,51	5,72	6,99	7,44	7,94	7,02	7,47	7,99
FCCOP class DF	(E)		E											
Water flow DF	(3)	l/h	449	469	486	452	474	492	602	641	684	604	643	688
Water pressure drop DF	(3)(E)	kPa	10	11	12	12	13	14	20	22	25	8	9	10
Additional coil DF - number of rows			1			1			1			1		
Total sound power level DF	(4)	dB(A)	61	64	69	59	63	69	62	67	72	62	67	72
Inlet + radiated sound power level DF	(4)(E)	dB(A)	56	60	66	56	60	66	60	64	70	60	64	70
Outlet sound power level DF	(4)(E)	dB(A)	55	59	65	59	62	65	58	63	69	58	63	69

(1) Water temperature 7°C/12°C, air temperature dry bulb 27°C, wet bulb 19°C (47% relative humidity) according to EN1397:2021

(2) Water temperature 7°C / 12°C, air temperature dry bulb 27°C, wet bulb 19°C (47% relative humidity)

(3) Water temperature 65°C / 55°C, air temperature 20°C

(4) Sound power measured according to standards ISO 3741 and ISO 3742

(E) EUROVENT certified data

Power supply 230-1-50 (V-ph-Hz)

RATED TECHNICAL DATA 4 PIPES

UTN			19A			22A			22D			30A		
Speed			min	med	max	min	med	max	min	med	max	min	med	max
Rated air flow DF	(E)	m ³ /h	1143	1470	1545	1423	1795	2184	1468	1871	2332	2065	2590	3154
Available static pressure DF	(E)	Pa	38	50	62	31	50	74	23	50	78	32	50	74
Power input DF	(E)	W	290	380	505	370	535	750	370	535	750	870	1090	1300
Total cooling capacity DF	(1)(E)	kW	7,17	8,98	10,0	9,12	11,0	12,9	8,34	10,0	11,7	12,9	15,3	17,7
Sensible cooling capacity DF	(1)(E)	kW	5,30	6,67	8,59	6,71	8,22	9,68	6,29	7,66	9,07	9,34	11,3	13,4
FCEER class DF	(E)		E											
Water flow DF	(2)	l/h	1237	1549	1732	1570	1903	2216	1436	1722	2010	2216	2633	3041
Water pressure drop DF	(2)(E)	kPa	20	30	35	12	16	22	15	21	28	27	37	48
Heating capacity DF	(3)(E)	kW	7,80	9,80	10,8	10,6	12,3	13,9	10,9	12,6	14,4	14,8	17,0	19,2
FCCOP class DF	(E)		D			D			D			E		
Water flow DF	(3)	l/h	1338	1679	1854	916	1059	1194	935	1087	1242	1273	1466	1652
Water pressure drop DF	(3)(E)	kPa	22	29	34	6	8	10	6	8	10	12	16	20
Additional coil DF - number of rows			1			2			2			2		
Total sound power level DF	(4)	dB(A)	61	67	71	60	67	74	60	67	74	69	73	78
Inlet + radiated sound power level DF	(4)(E)	dB(A)	59	65	69	58	65	72	58	65	72	67	71	76
Outlet sound power level DF	(4)(E)	dB(A)	57	63	68	57	64	71	57	64	71	66	70	75

UTN			30D			40A			40D		
Speed			min	med	max	min	med	max	min	med	max
Rated air flow DF	(E)	m ³ /h	2083	2626	3187	3345	4002	4837	3073	3637	4321
Available static pressure DF	(E)	Pa	31	50	74	35	50	73	36	50	70
Power input DF	(E)	W	870	1090	1300	650	820	1150	650	820	1150
Total cooling capacity DF	(1)(E)	kW	11,6	13,8	15,8	18,6	21,2	24,2	15,2	17,2	19,2
Sensible cooling capacity DF	(1)(E)	kW	8,58	10,4	12,2	14,4	16,8	19,5	11,9	13,5	15,3
FCEER class DF	(E)		E			D			E		
Water flow DF	(2)	l/h	1996	2371	2728	3297	3779	4347	2722	3085	3493
Water pressure drop DF	(2)(E)	kPa	24	32	41	16	21	26	17	23	29
Heating capacity DF	(3)(E)	kW	14,9	17,2	19,3	18,3	20,2	22,2	18,5	20,4	22,6
FCCOP class DF	(E)		E			D			D		
Water flow DF	(3)	l/h	1281	1478	1662	1601	1766	1948	1620	1790	1983
Water pressure drop DF	(3)(E)	kPa	13	17	21	9	11	13	9	11	13
Additional coil DF - number of rows			2			2			2		
Total sound power level DF	(4)	dB(A)	69	73	78	70	74	79	70	74	79
Inlet + radiated sound power level DF	(4)(E)	dB(A)	67	71	76	68	72	77	68	72	77
Outlet sound power level DF	(4)(E)	dB(A)	66	70	75	67	71	76	67	71	76

(1) Water temperature 7°C/12°C, air temperature dry bulb 27°C, wet bulb 19°C (47% relative humidity) according to EN1397:2021

(2) Water temperature 7°C / 12°C, air temperature dry bulb 27°C, wet bulb 19°C (47% relative humidity)

(3) Water temperature 65°C / 55°C, air temperature 20°C

(4) Sound power measured according to standards ISO 3741 and ISO 3742

(E) EUROVENT certified data

Power supply 230-1-50 (V-ph-Hz)

DIMENSIONAL DRAWINGS

UTN 06 - 19

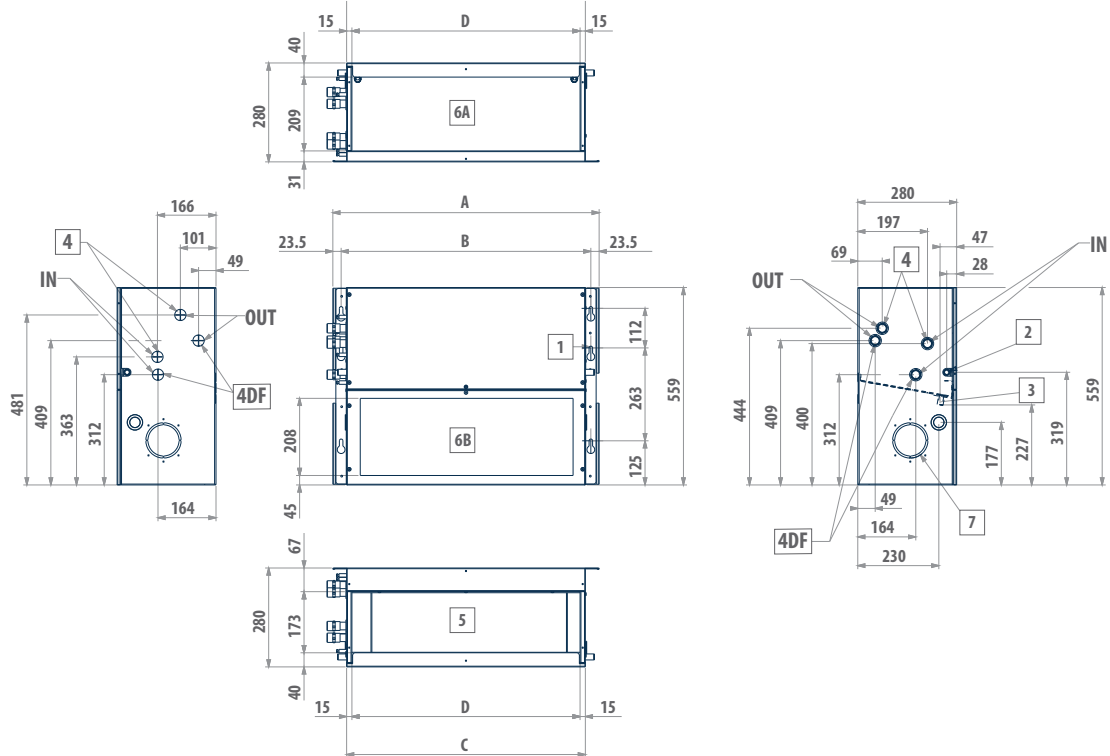

LEGEND

1	No. 6 quick-coupling slots
2	Condensate drainage horizontal installation
3	Condensate drainage vertical installation
4	Water connections on the right
4DF	Water connections additional heat exchanger
5	Air outlet
6	Air intake
6-A	supply condition
6-B	modifiable during installation
7	Circular pre-cut slot (\varnothing 100 mm) for intake of external air

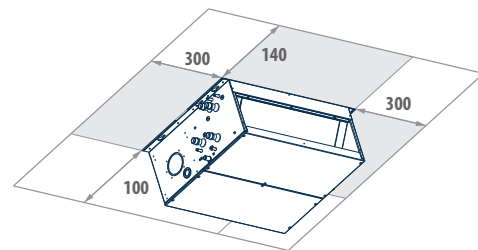

UTN	A mm	B mm	C mm	D mm	4 "	4DF "	2 mm	3 mm	kg
6D - 6A - 8D - 8A	754	707	676	646	3/4	3/4	17	17	33
12D - 12A	964	917	886	856	3/4	3/4	17	17	42
16D - 16A - 19A	1174	1127	1096	1066	3/4	3/4	17	17	49

MODELS 6 AND 6A AVAILABLE ON/OFF VERSION ONLY

DIMENSIONAL DRAWINGS

UTN 22 - 40

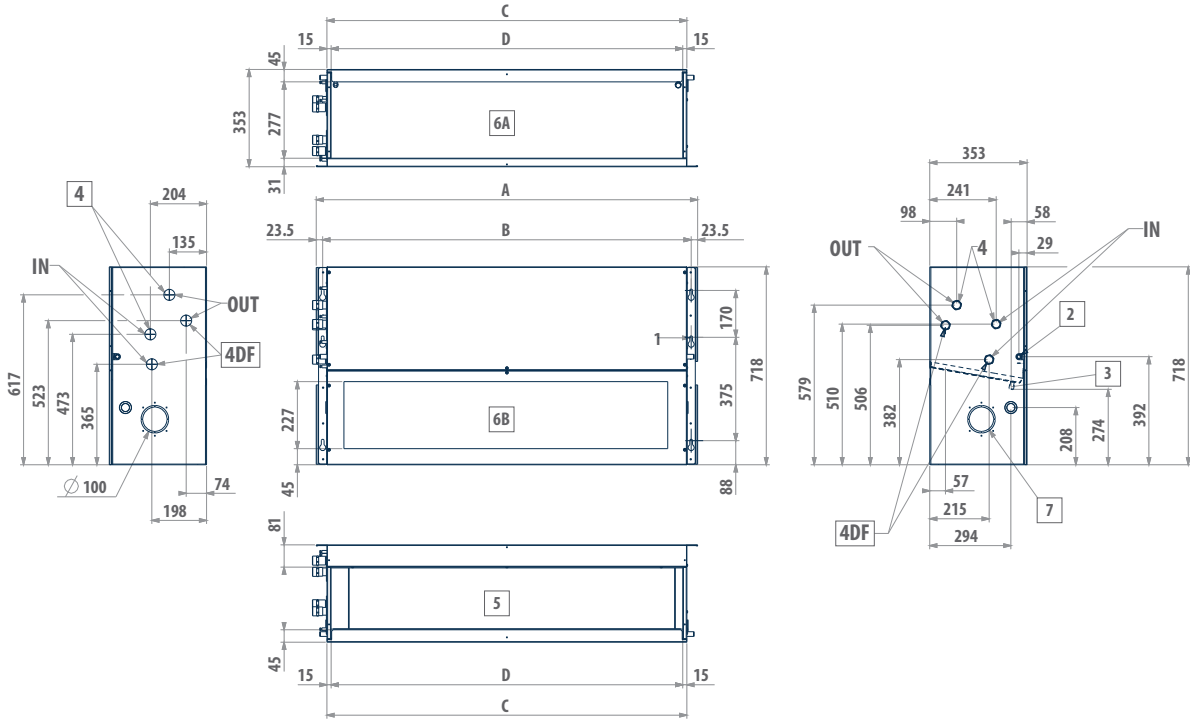

LEGEND

1	No. 6 quick-coupling slots
2	Condensate drainage horizontal installation
3	Condensate drainage vertical installation
4	Water connections on the right
4DF	Water connections additional heat exchanger
5	Air outlet
6	Air intake
6-A	supply condition
6-B	modifiable during installation
7	Circular pre-cut slot (Ø 100 mm) for intake of external air

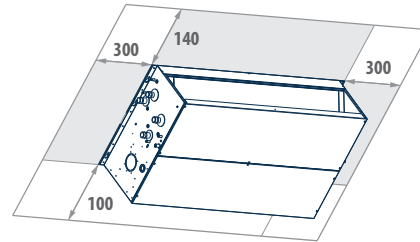

UTN	A mm	B mm	C mm	D mm	4 "	4DF "	2 mm	3 mm	📦 kg
22D - 22A	1174	1127	1096	1066	1	1	17	17	67
30D - 30A	1384	1337	1306	1276	1	1	17	17	80
40D - 40A	1594	1547	1516	1486	1	1	17	17	90

High-head thermal ventilating units with EC motor

UTN i 4 - 18 kW



EC Motor



2 pipes systems



4 pipes systems



Centrifugal fan



Ducted

High efficiency and low noise emissions for ducted applications

The thermal ventilating units of the UTN i range with inverter motors and cooling capacities of 4 to 18 kW represent an evolution of the UTN series: keeping in pace with current legislation on energy savings and equipment efficiency and the most recent technological developments in the realm of electric motors, Galletti offers ducted units equipped with inverter-controlled permanent magnet EC motors. This solution makes it possible to reduce electricity consumption by up to 70% compared to a traditional asynchronous motor and at the same time offers the possibility of achieving a precise regulation of air flow, thanks to its ability to vary the number of fan revolutions in a continuous and efficient manner. The particular features which characterize the UTN series, namely, the height of 280 mm to enable the units to be accommodated in false ceilings, flexibility of installation and connection to air ducts and wide selection of accessories, are maintained to ensure the same standards of quality. Moreover, the availability of heat exchangers with a large number of rows makes it possible to use a low-temperature thermal carrier fluid in the heating mode, which means further energy savings.

PLUS

- » Permanent magnet EC motor
- » Low electricity consumption
- » Easy setup of ventilation section
- » Reduced height across the entire range (280 mm)
- » Vertical and horizontal installation
- » Wide range of available accessories
- » High flexibility of installation

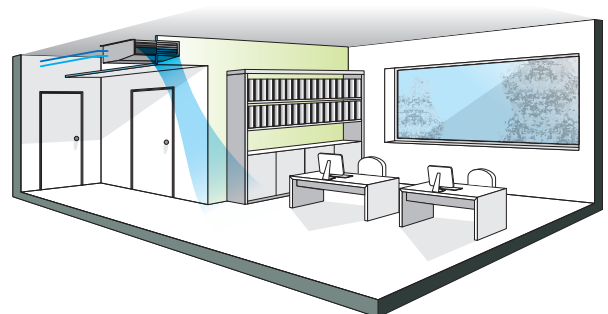

Comfort and quiet operation

Thanks to the possibility of regulating the rotation speed of the motor with high precision, UTN i is well-suited to interiors where keeping noise levels low is a must.

AVAILABLE VERSIONS

UTXXXILO...0A Thermal ventilating unit suitable for 2-pipe systems

UTXXXILL...0A Thermal ventilating unit suitable for 4-pipe systems (2 heat exchangers)

UTXXXILO...02 The version with double panelling is made with pre-painted sheet steel insulated with class 0 fire-resistant rockwool **(On request)**

MAIN COMPONENTS

Structure

Made of galvanized sheet steel insulated with sound-deadening, heat-insulating, self-extinguishing closed-cell material to reduce noise emissions and prevent the formation of condensate on the outside surface.

Heat exchanger

It is composed of copper tubing and aluminium fins fixed by expansion. Water connections are reversible. An additional exchanger is available for installing the unit in 4-pipe systems.

Fan

The aluminium fans are of the centrifugal type, with double suction and staggered blades to reduce noise emissions. They are statically and dynamically balanced to minimize the stresses transmitted to the motor shaft.



Electric motor EC

Permanent magnet motor. The unit is equipped with an inverter board to control the motor, that makes it possible to precisely set the maximum rotation speed of the motor (control signal 0-10 V).

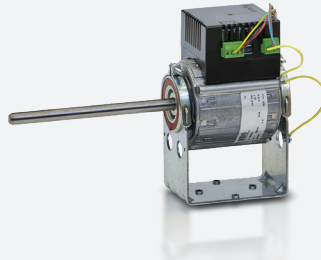

Condensate collection and drainage system

It consists of two insulated galvanized sheet steel trays designed for horizontal and vertical installation.

Filter module

The air filter, made of regenerable acrylic fibre, is available as an accessory in filtration classes G2 or G4.

ACCESSORIES

Electronic microprocessor control panels with display

DIST	MYCOMFORT controller spacer for wall mounting
EVO-2-TOUCH	2.8" touch screen user interface for EVO control
EVOBOARD	Circuit board for EVO control
EVODISP	User interface with display for EVO controller
EYNAVEL	Device for Wi-Fi or Bluetooth communication between EVOBOARD and smartphone
MCLE	Microprocessor control with display MYCOMFORT LARGE
MCSUE	Humidity sensor for MYCOMFORT LARGE and EVO
MCSWE	Water sensor for MYCOMFORT and EVO controllers

Electronic microprocessor control panels

TED 10	Electronic controller for BLDC fan equipped with inverter and ON/OFF valves 230 V
TED SWA	Water temperature sensor for TED controls

Power interface and regulating louver controllers

CSD	Recess mounted controller for opening and closing the SM motor-driven regulating louver
------------	---

Auxiliary water drip trays, insulating shell, condensate drainage pump

KSC	Condensate drainage pump kit
------------	------------------------------

Electrical heating elements

RE	Heating element with installation kit, relay box and safety devices
-----------	---

Air inlet and outlet grilles

GM	Aluminium air outlet grille with 2-row fins and subframe
GR	Air intake grille with subframe
GRF	Air intake grille with subframe and filter

External air intake louvers

PA90	Motor-driven external air intake louver
-------------	---

Valves

V2VDF+STD	2-way valves, ON/OFF or MODULATING actuator, 230 V or 24 V power supply, hydraulic kit, for main and additional heat exchanger
------------------	--

V2VSTD	2-way valve, ON/OFF or MODULATING actuator, 230 V or 24 V power supply, hydraulic kit, for main heat exchanger
V3VDF	3-way valves, ON/OFF or MODULATING actuator, 230 V or 24 V power supply, hydraulic kit, for additional heat exchanger
V3VSTD	2-way valves, ON/OFF or MODULATING actuator, 230 V or 24 V power supply, hydraulic kit, for main heat exchanger
VPI	2-way valves pressure independent, ON/OFF actuator, 230 V power supply, hydraulic kit, for main heat exchanger

Plenum, air intake modules, air inlet and outlet connectors and cabinets

G90	90° connection for intake/delivery
MAF	Air intake module with G2 flat air filter
MAFO	Air intake module with G4 undulated air filter
PCOC	Junction panel with rectangular duct
PCOF	Junction panel with flexible circular duct Ø 200

Flexible ducts - caps

TFA	Not insulated flexible ducts, Ø 200 mm (6 m length undivisible)
TFM	Insulated flexible ducts, Ø 200 mm (6 m length undivisible)
TP	Plastic cap Ø 200 mm

Air inlet and outlet plenum box

CA	Air Inlet plenum box with double row grille
CAF	Air Inlet plenum box with double row grille 300 x 600 mm and filter G2
CM	Insulated air outlet plenum box with grille

Accessories

UYBP	Hot water post-heating exchanger kit
VRCH	Auxiliary water drip tray for horizontal installation units
VRCV	Auxiliary water drip tray for vertical installation units

Vibration-damping couplings

GA	Vibration-damping coupling
GAT	Heat-resistant vibration-damping coupling

RATED TECHNICAL DATA 2 PIPES

UTN i			8A			8D			12A			12D		
Speed			min	med	max	min	med	max	min	med	max	min	med	max
Control voltage	(E)	V	6,00	7,40	8,90	6,00	7,40	8,90	7,30	8,00	8,80	7,30	8,00	8,80
Rated air flow	(E)	m ³ /h	532	692	791	534	700	802	1000	1107	1203	1019	1134	1238
Available static pressure	(E)	Pa	30	50	65	29	50	65	41	50	59	40	50	59
Power input	(E)	W	40	73	133	40	73	112	102	125	152	102	125	170
Total cooling capacity	(1)(E)	kW	3,38	4,20	4,65	2,83	3,47	3,80	5,78	6,25	6,65	5,22	5,65	6,01
Sensible cooling capacity	(1)(E)	kW	2,54	3,19	3,56	2,19	2,70	2,98	4,35	4,73	5,04	3,90	4,20	4,47
FCEER class	(E)		B			C			C			C		
Water flow	(2)	l/h	582	723	801	487	598	654	995	1076	1145	899	973	1035
Water pressure drop	(2)(E)	kPa	8	12	14	10	14	17	15	17	19	18	21	24
Heating capacity	(3)(E)	kW	3,55	4,36	4,83	3,04	3,69	4,05	6,29	6,80	7,26	5,59	6,03	6,42
FCCOP class			B			B			C			C		
Water flow	(3)	l/h	611	751	832	523	635	697	1083	1171	1250	963	1038	1106
Water pressure drop	(3)(E)	kPa	7	11	13	9	13	15	14	17	18	17	19	22
Standard coil - number of rows			4			3			4			3		
Total sound power level	(4)	dB(A)	54	61	66	54	61	66	61	63	69	59	63	69
Inlet + radiated sound power level	(4)(E)	dB(A)	52	59	64	52	59	64	56	60	66	56	60	66
Outlet sound power level	(4)(E)	dB(A)	51	58	63	51	58	63	59	59	65	55	59	65

UTN i			16A			16D			19A			22A		
Speed			min	med	max	min	med	max	min	med	max	min	med	max
Control voltage	(E)	V	6,70	7,70	8,90	6,70	7,70	8,90	6,60	8,00	9,00	3,80	5,90	7,90
Rated air flow	(E)	m ³ /h	1198	1371	1581	1207	1384	1606	1166	1500	1577	1436	1819	2222
Available static pressure	(E)	Pa	38	50	66	38	50	67	33	50	62	31	50	75
Power input	(E)	W	124	170	248	124	170	248	109	190	247	135	210	407
Total cooling capacity	(1)(E)	kW	6,84	7,62	8,49	6,20	6,84	7,57	7,50	9,36	10,4	9,43	11,5	13,6
Sensible cooling capacity	(1)(E)	kW	5,40	6,07	6,83	5,01	5,60	6,29	7,35	9,17	10,3	6,99	8,65	10,3
FCEER class	(E)		C			C			C			B		
Water flow	(2)	l/h	1178	1312	1462	1068	1178	1304	1289	1663	1789	1644	2010	2366
Water pressure drop	(2)(E)	kPa	11	13	16	17	20	24	24	37	43	12	17	22
Heating capacity	(3)(E)	kW	7,28	8,04	8,93	6,47	7,11	7,88	7,94	9,96	11,0	9,73	11,7	13,7
FCCOP class			C			C			B			B		
Water flow	(3)	l/h	1254	1384	1538	1114	1224	1357	1365	1715	1857	1676	2020	2354
Water pressure drop	(3)(E)	kPa	10	12	14	15	17	21	22	29	34	10	14	19
Standard coil - number of rows			4			3			4			4		
Total sound power level	(4)	dB(A)	62	67	72	62	67	72	61	67	71	60	67	74
Inlet + radiated sound power level	(4)(E)	dB(A)	60	64	70	60	64	70	59	65	69	58	65	72
Outlet sound power level	(4)(E)	dB(A)	58	63	69	58	63	69	57	63	68	57	64	71

(1) Water temperature 7°C/12°C, air temperature dry bulb 27°C, wet bulb 19°C (47% relative humidity) according to EN1397:2021

(2) Water temperature 7°C / 12°C, air temperature dry bulb 27°C, wet bulb 19°C (47% relative humidity)

(3) Water temperature 45°C / 40°C, air temperature 20°C

(4) Sound power measured according to standards ISO 3741 and ISO 3742

(E) EUROVENT certified data

Power supply 230-1-50 (V-ph-Hz)

NOTE: The dimensional drawings of the UTN i inverter units are the same of the UTN ON/OFF version. They are reported from page 124

RATED TECHNICAL DATA 2 PIPES

UTN i			22D			30A			30D		
Speed			min	med	max	min	med	max	min	med	max
Control voltage	(E)	V	3,90	6,10	8,30	3,60	5,50	7,20	3,60	5,60	7,20
Rated air flow	(E)	m ³ /h	1483	1898	2376	2074	2604	3174	2092	2641	3207
Available static pressure	(E)	Pa	30	50	78	32	50	74	31	50	74
Power input	(E)	W	140	247	441	195	310	512	200	320	445
Total cooling capacity	(1)(E)	kW	8,64	10,4	12,2	13,6	16,2	18,6	12,3	14,6	16,8
Sensible cooling capacity	(1)(E)	kW	6,58	8,07	9,66	10,1	12,2	14,3	9,29	11,2	13,0
FCEER class	(E)		C			B			C		
Water flow	(2)	l/h	1509	1827	2163	2365	2823	3270	2145	2561	2953
Water pressure drop	(2)(E)	kPa	15	21	29	27	37	48	21	29	37
Heating capacity	(3)(E)	kW	9,06	10,8	12,7	13,7	16,4	19,1	12,7	15,0	17,3
FCCOP class			C			B			C		
Water flow	(3)	l/h	1560	1867	2190	2359	2824	3289	2183	2592	2977
Water pressure drop	(3)(E)	kPa	14	19	25	23	32	41	18	25	31
Standard coil - number of rows			3			5			4		
Total sound power level	(4)	dB(A)	65	71	74	69	73	78	69	73	78
Inlet + radiated sound power level	(4)(E)	dB(A)	63	69	72	67	71	76	67	71	76
Outlet sound power level	(4)(E)	dB(A)	61	67	71	66	70	75	66	70	75

(1) Water temperature 7°C/12°C, air temperature dry bulb 27°C, wet bulb 19°C (47% relative humidity) according to EN1397:2021

(2) Water temperature 7°C / 12°C, air temperature dry bulb 27°C, wet bulb 19°C (47% relative humidity)

(3) Water temperature 45°C / 40°C, air temperature 20°C

(4) Sound power measured according to standards ISO 3741 and ISO 3742

(E) EUROVENT certified data

Power supply 230-1-50 (V-ph-Hz)

NOTE: The dimensional drawings of the UTN i inverter units are the same of the UTN ON/OFF version. They are reported from page 124

RATED TECHNICAL DATA 4 PIPES

UTN i			8A			8D			12A			12D		
Speed			min	med	max	min	med	max	min	med	max	min	med	max
Control voltage	(E)	V	6,00	7,40	8,90	6,00	7,40	8,90	7,30	8,00	8,80	7,30	8,00	8,80
Rated air flow DF	(E)	m ³ /h	529	686	783	531	694	793	985	1088	1182	1005	1115	1211
Available static pressure DF	(E)	Pa	30	50	65	29	50	65	41	50	59	41	50	59
Power input DF	(E)	W	40	73	112	45	73	112	102	125	152	102	125	152
Total cooling capacity DF	(1)(E)	kW	3,36	4,17	4,61	2,82	3,44	3,76	5,71	6,17	6,55	5,17	5,58	5,91
Sensible cooling capacity DF	(1)(E)	kW	2,52	3,17	3,53	2,18	2,68	2,95	4,30	4,66	4,97	3,84	4,15	4,39
FCEER class DF	(E)		B			C			C			C		
Water flow DF	(2)	l/h	579	718	794	486	592	647	983	1062	1128	890	961	1018
Water pressure drop DF	(2)(E)	kPa	8	12	14	10	14	17	15	17	19	18	21	23
Heating capacity DF	(3)(E)	kW	3,23	3,66	3,89	3,23	3,68	3,91	5,21	5,45	5,65	5,25	5,51	5,72
FCCOP class DF	(E)		B			B			B			C		
Water flow DF	(3)	l/h	278	315	355	278	317	337	449	469	486	452	474	492
Water pressure drop DF	(3)(E)	kPa	5	6	7	5	6	7	10	11	12	12	13	14
Additional coil DF - number of rows			1			1			1			1		
Total sound power level DF	(4)	dB(A)	54	61	66	54	61	66	61	64	69	59	63	69
Inlet + radiated sound power level DF	(4)(E)	dB(A)	52	59	64	52	59	64	56	60	66	56	60	66
Outlet sound power level DF	(4)(E)	dB(A)	51	58	63	51	58	63	55	59	65	55	59	65

UTN i			16A			16D			19A			22A		
Speed			min	med	max	min	med	max	min	med	max	min	med	max
Control voltage	(E)	V	6,70	7,70	8,90	7,00	7,70	8,90	6,60	8,00	9,00	3,80	5,90	7,90
Rated air flow DF	(E)	m ³ /h	1184	1349	1550	991	1094	1212	1143	1470	1545	1423	1795	2184
Available static pressure DF	(E)	Pa	38	50	66	38	50	61	38	50	62	31	50	74
Power input DF	(E)	W	137	198	294	124	170	248	109	190	247	138	210	305
Total cooling capacity DF	(1)(E)	kW	6,77	7,52	8,35	6,14	6,75	7,46	5,62	7,00	9,10	9,35	11,3	13,3
Sensible cooling capacity DF	(1)(E)	kW	5,34	5,98	6,71	4,96	5,52	6,19	5,44	6,86	8,85	6,94	8,55	10,1
FCEER class DF	(E)		C			C			C			B		
Water flow DF	(2)	l/h	1166	1295	1438	1057	1162	1285	1268	1582	1777	1631	1987	2336
Water pressure drop DF	(2)(E)	kPa	15	20	23	16	19	23	20	31	36	12	16	22
Heating capacity DF	(3)(E)	kW	6,99	7,44	7,94	7,02	7,47	7,99	7,80	9,80	10,8	10,6	12,3	13,9
FCCOP class DF	(E)		C			C			B			B		
Water flow DF	(3)	l/h	602	641	684	604	643	688	1338	1679	1854	916	1059	1194
Water pressure drop DF	(3)(E)	kPa	20	22	25	22	24	27	22	29	34	6	8	10
Additional coil DF - number of rows			1			1			1			2		
Total sound power level DF	(4)	dB(A)	62	67	72	62	67	72	61	67	71	60	67	74
Inlet + radiated sound power level DF	(4)(E)	dB(A)	60	64	70	60	64	70	59	65	69	61	65	72
Outlet sound power level DF	(4)(E)	dB(A)	58	63	69	58	63	69	57	63	68	57	64	71

(1) Water temperature 7°C/12°C, air temperature dry bulb 27°C, wet bulb 19°C (47% relative humidity) according to EN1397:2021

(2) Water temperature 7°C / 12°C, air temperature dry bulb 27°C, wet bulb 19°C (47% relative humidity)

(3) Water temperature 65°C / 55°C, air temperature 20°C

(4) Sound power measured according to standards ISO 3741 and ISO 3742

(E) EUROVENT certified data

Power supply 230-1-50 (V-ph-Hz)

NOTE: The dimensional drawings of the UTN i inverter units are the same of the UTN ON/OFF version. They are reported from page 124

RATED TECHNICAL DATA 4 PIPES

UTN i			22D			30A			30D		
Speed			min	med	max	min	med	max	min	med	max
Control voltage	(E)	V	3,90	6,10	8,30	3,60	5,50	7,20	3,60	5,60	7,20
Rated air flow DF	(E)	m ³ /h	1468	1871	2332	2065	2590	3154	2083	2626	3187
Available static pressure DF	(E)	Pa	30	50	78	32	50	74	31	50	74
Power input DF	(E)	W	144	220	317	221	345	510	223	350	596
Total cooling capacity DF	(1)(E)	kW	8,56	10,3	12,1	13,6	16,0	18,6	12,2	14,5	16,6
Sensible cooling capacity DF	(1)(E)	kW	6,51	7,98	9,50	9,99	12,0	14,3	9,23	11,1	13,0
FCEER class DF	(E)		C			C			C		
Water flow DF	(2)	l/h	1493	1808	2130	2358	2811	3254	2138	2550	2940
Water pressure drop DF	(2)(E)	kPa	15	21	28	27	37	48	21	28	36
Heating capacity DF	(3)(E)	kW	10,9	12,6	14,4	14,8	17,0	19,2	14,9	17,2	19,3
FCCOP class DF	(E)		B			C			C		
Water flow DF	(3)	l/h	935	1087	1242	1273	1466	1652	1281	1478	1662
Water pressure drop DF	(3)(E)	kPa	6	8	10	13	16	20	13	17	21
Additional coil DF - number of rows			2			2			2		
Total sound power level DF	(4)	dB(A)	60	67	74	69	73	78	69	73	78
Inlet + radiated sound power level DF	(4)(E)	dB(A)	58	65	72	67	71	76	67	71	76
Outlet sound power level DF	(4)(E)	dB(A)	57	64	71	66	70	75	66	70	75

- (1) Water temperature 7°C/12°C, air temperature dry bulb 27°C, wet bulb 19°C (47% relative humidity) according to EN1397:2021
 (2) Water temperature 7°C / 12°C, air temperature dry bulb 27°C, wet bulb 19°C (47% relative humidity)
 (3) Water temperature 65°C / 55°C, air temperature 20°C
 (4) Sound power measured according to standards ISO 3741 and ISO 3742
 (E) EUROVENT certified data
 Power supply 230-1-50 (V-ph-Hz)

NOTE: The dimensional drawings of the UTN i inverter units are the same of the UTN ON/OFF version. They are reported from page 124



FH - FAN HEATERS

AREO	p.134
AREOi	p.144
DST	p.148

Air conditioning fan heaters with ON/OFF motor

AREO 8 - 101 kW



Hygrothermal comfort in the industrial and commercial sectors

In line with recent regulatory developments regarding energy efficiency, Galletti is updating its offering of fan heaters for heating and cooling systems to be used in industrial and commercial environments of any volume. The new AREO, which was designed to meet the stringent requirements of the ERP Directive, retains unchanged the distinctive aspects of the original design, that is, extreme reliability and sturdiness.

AREO's cover, which is made of pre-painted steel sheet, possesses an original design with a rounded shape that enhances its aesthetic form.

The AREO range consists of 16 models that, limited to the only heating version, can be either wall mounted (horizontal air flow) or ceiling mounted (vertical air flow). The cooling version is equipped with a new system in order to collect condensation and further insulation inside the cover.

The units are available in 6 sizes with 2-, 3- or 4-row heat exchangers ensuring an efficient performance with hot water supplied by a boiler or heat pump (4-row models).



2 pipes systems



Vertical installation



Horizontal installation (not for AREO C)



Heating



Cooling (only for AREO C)

PLUS

- » Low sound levels
- » Wide operating range (up to 60 °C intake air)
- » Axial fan with blades with an aerodynamic profile (HyBlade® technology)
- » Electric motor, class F, approved for continuous operation
- » Wide operating range (up to 60 °C intake air)



AVAILABLE VERSIONS

Single-phase and three-phase power supply.

AREO P

Fan heaters for hot water heating, with side water connections.

AREO H

Fan heaters for hot water heating, with vertical water connections, for replacement of indoor units installed in existing systems.

AREO L

Fan heaters for hot water heating, equipped with air-curtain diffuser, ceiling mounted.

AREO C

Single phase power supplied fan heaters suitable either for heating or cooling mode, equipped with asynchronous electric motor and side water connections, wall mounted.

MAIN COMPONENTS
Fan drive assembly

The motor and fan are a single integrated unit optimized to achieve maximum aeraulic efficiency. In fact, conformity to ERP is guaranteed, even for the versions with single-phase power supply.

Electric motor

Tropicalized motor directly coupled to an external rotor, standard, with the following features:

- equipped with internal thermal protection
- windings in class F
- protection rating IP54
- maintenance-free ball bearings

Axial fan

With blades with an optimized aerodynamic profile (HyBlade® technology), statically balanced, inserted in a housing that enhances aeraulic performance and minimizes noise.

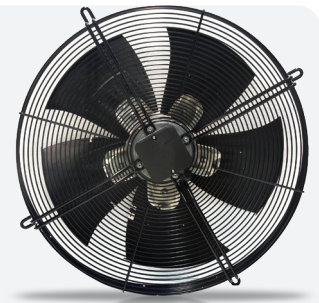
Cabinet

Made of pre-painted steel sheet, complete with ABS corners, and manually adjustable aluminum baffles located on the air outlet for optimum distribution in the room to be heated.

Safety cage

Made of electrogalvanised steel wire, it supports the motor and is fixed to the cabinet by means of vibration-damping supports.

Heat exchanger

Made of copper pipes and aluminium fins of high thermal conductivity to optimize heat exchange.

RVM regulator for ventilation speed adjustment in single phase power supplied models

The speed regulator RVM can vary the effective value on the load by controlling the wave shape caused by a TRIAC. This accessory can be used only coupled to single phase power supplied models, and allows a fan heater manual ventilation speed adjustment depending on different needs. The device is also equipped with special filters in order to suppress noise induced on the supplied line or irradiated from the equipment and a minimum speed manually adjustable trimmer. This accessory is yet included with AREO C cooling series.

RVM manual power regulator for monophase power supply FAN HEATERS (not available for frame 5).

ACCESSORIES
Electromechanical control panels

CST	Delta/star switch for installation in electrical box
CSTP	Delta/star switch with box wall mounted
RVM	RVM manual power regulator for monophase power supply FAN HEATERS (not available for frame 5)
TA2	Electromechanical room thermostat with summer/winter selection

Power interface and regulating louver controllers

CSD	Recess mounted controller for opening and closing the SM motor-driven regulating louver
------------	---

Accessories

VA	Auxiliary tray for collecting condensate
-----------	--

Fixation templates

DFC	Template for column installation
------------	----------------------------------

DFO	Adjustable template for wall/column installation
------------	--

DFP	Template for wall installation
------------	--------------------------------

Protective grill for gyms (ball shield)

R	Protective net for gyms
----------	-------------------------

Diffusors

DO	Two-row adjustable fin diffuser
-----------	---------------------------------

LA	Air curtain diffuser
-----------	----------------------

External air intake

PAE	External air intake
------------	---------------------

PAEM	Manual mixing louver
-------------	----------------------

PAEMM	Motor driven mixer louver, 24 V power supply with spring return
--------------	---

External air intake rain protection grille

GR	Air intake grille with subframe
-----------	---------------------------------

RATED TECHNICAL DATA AREO P - HEATING MODE

AREO P			12	12	13	13	14	14	
Power supply		V-ph-Hz	230 - 1 - 50						
no. of poles			4	6	4	6	4	6	
Motor connctions			Mono	Mono	Mono	Mono	Mono	Mono	
Rated air flow		m³/h	1280	1000	1140	900	1040	800	
Heating capacity	(1)	kW	9,77	8,48	12,4	10,7	14,2	11,9	
Water flow	(1)	l/h	863	749	1097	946	1252	1047	
Water pressure drop	(1)	kPa	29	23	22	17	17	12	
Sound power level	(2)	dB(A)	64	59	64	59	65	60	
Power input		W	69	49	69	50	70	51	

AREO P			22	22	23	23	24	24	
Power supply		V-ph-Hz	230 - 1 - 50						
no. of poles			4	6	4	6	4	6	
Motor connctions			Mono	Mono	Mono	Mono	Mono	Mono	
Rated air flow		m³/h	3020	2100	2630	1850	2600	1800	
Heating capacity	(1)	kW	19,9	16,2	25,6	20,6	28,9	22,9	
Water flow	(1)	l/h	1754	1432	2256	1820	2555	2022	
Water pressure drop	(1)	kPa	23	16	29	20	19	13	
Sound power level	(2)	dB(A)	76	64	76	65	77	65	
Power input		W	198	110	210	114	212	120	

AREO P			32	32	32	33	33	33
Power supply		V-ph-Hz	230 - 1 - 50	400 - 3 - 50	400 - 3 - 50	230 - 1 - 50	400 - 3 - 50	400 - 3 - 50
no. of poles			4	4	6	4	4	6
Motor connctions			Mono	Delta	Star	Mono	Delta	Star
Rated air flow		m³/h	4500	4300	3200	4150	4000	2900
Heating capacity	(1)	kW	35,6	34,7	29,2	39,5	38,6	31,8
Water flow	(1)	l/h	3143	3060	2579	3486	3411	2806
Water pressure drop	(1)	kPa	20	19	14	18	17	12
Sound power level	(2)	dB(A)	76	76	69	76	76	69
Power input		W	320	315	175	340	330	180

AREO P			34	34	34	42	42	42
Power supply		V-ph-Hz	230 - 1 - 50	400 - 3 - 50	400 - 3 - 50	230 - 1 - 50	400 - 3 - 50	400 - 3 - 50
no. of poles			4	4	6	4	4	6
Motor connctions			Mono	Delta	Star	Mono	Delta	Star
Rated air flow		m³/h	4050	3900	2800	6900	7100	5600
Heating capacity	(1)	kW	45,1	44,0	35,6	53,4	54,3	47,4
Water flow	(1)	l/h	3980	3886	3145	4718	4793	4185
Water pressure drop	(1)	kPa	29	28	19	37	38	30
Sound power level	(2)	dB(A)	77	77	70	75	73	67
Power input		W	345	340	182	623	650	450

AREO P			43	43	43	44	44	44
Power supply		V-ph-Hz	230 - 1 - 50	400 - 3 - 50	400 - 3 - 50	230 - 1 - 50	400 - 3 - 50	400 - 3 - 50
no. of poles			4	4	6	4	4	6
Motor connctions			Mono	Delta	Star	Mono	Delta	Star
Rated air flow		m³/h	6400	6550	5300	6200	6400	5150
Heating capacity	(1)	kW	59,6	60,4	53,2	66,8	68,1	59,5
Water flow	(1)	l/h	5259	5329	4695	5894	6009	5250
Water pressure drop	(1)	kPa	36	37	30	23	24	19
Sound power level	(2)	dB(A)	74	74	68	75	75	69
Power input		W	635	690	465	655	700	470

- (1) Water temperature 85°C / 75°C, air temperature 15°C - 100% of the max speed
 (2) Sound power measured according to standards ISO 3741 - 100% of the max speed

RATED TECHNICAL DATA AREO P - HEATING MODE

AREO P			53	53	53	54	54	54
Power supply		V-ph-Hz	230 - 1 - 50	400 - 3 - 50	400 - 3 - 50	230 - 1 - 50	400 - 3 - 50	400 - 3 - 50
no. of poles			6	4	6	6	4	6
Motor connections			Mono	Delta	Star	Mono	Delta	Star
Rated air flow		m ³ /h	6200	7900	6450	5900	7600	6200
Heating capacity	(1)	kW	60,8	70,2	62,3	66,2	77,4	68,3
Water flow	(1)	l/h	5373	6202	5497	5852	6834	6033
Water pressure drop	(1)	kPa	19	25	20	21	27	22
Sound power level	(2)	dB(A)	69	76	72	71	77	73
Power input		W	374	732	775	380	755	780

AREO P			63	63	63	64	64	64
Power supply		V-ph-Hz	230 - 1 - 50	400 - 3 - 50	400 - 3 - 50	230 - 1 - 50	400 - 3 - 50	400 - 3 - 50
no. of poles			6	6	8	6	6	8
Motor connections			Mono	Delta	Star	Mono	Delta	Star
Rated air flow		m ³ /h	8100	8300	6500	7500	7650	6000
Heating capacity	(1)	kW	99,7	101	86,4	99,6	101	85,8
Water flow	(1)	l/h	8802	8943	7626	8795	8913	7571
Water pressure drop	(1)	kPa	29	30	23	29	29	22
Sound power level	(2)	dB(A)	65	72	67	71	72	67
Power input		W	560	575	380	582	590	390

- (1) Water temperature 85°C / 75°C, air temperature 15°C - 100% of the max speed
(2) Sound power measured according to standards ISO 3741 - 100% of the max speed

RATED TECHNICAL DATA AREO C - HEATING MODE

AREO C			12	12	13	13	14	14	22	22
Power supply		V-ph-Hz	230 - 1 - 50							
no. of poles			4	6	4	6	4	6	4	6
Air flow rate max heating		m ³ /h	1280	1000	1140	900	1040	800	3020	2100
Heating capacity	(1)	kW	9,77	8,48	12,4	10,7	14,2	11,9	19,9	16,2
Water flow	(1)	l/h	863	749	1097	946	1252	1047	1754	1432
Water pressure drop	(1)	kPa	29	23	22	17	17	12	23	16
Sound power level	(2)	dB(A)	64	59	64	59	65	60	76	64
Power input	(3)	W	67	49	69	50	70	51	198	110

AREO C			23	23	24	24	32	33	34	42
Power supply		V-ph-Hz	230 - 1 - 50							
no. of poles			4	6	4	6	4	4	4	4
Air flow rate max heating		m ³ /h	2630	1850	2600	1800	4500	4150	4050	6900
Heating capacity	(1)	kW	25,6	20,6	28,9	22,9	35,6	39,5	45,1	53,4
Water flow	(1)	l/h	2256	1820	2555	2022	3143	3486	3980	4718
Water pressure drop	(1)	kPa	29	20	19	13	20	18	29	37
Sound power level	(2)	dB(A)	76	65	77	65	76	76	77	75
Power input	(3)	W	210	114	212	120	320	340	345	623

AREO C			43	44	63	64
Power supply		V-ph-Hz	230 - 1 - 50			
no. of poles			4	4	6	6
Air flow rate max heating		m ³ /h	6400	6200	7695	7500
Heating capacity	(1)	kW	59,6	66,8	79,3	99,6
Water flow	(1)	l/h	5259	5894	8802	8795
Water pressure drop	(1)	kPa	36	23	29	29
Sound power level	(2)	dB(A)	74	75	69	71
Power input	(3)	W	635	655	560	582

- (1) Water temperature 85°C / 75°C, air temperature 15°C - 100% of the max speed
 (2) Sound power measured according to standards ISO 3741 - 100% of the max speed
 (3) Referred to maximum speed

RATED TECHNICAL DATA AREO C - COOLING MODE

AREO C			12	12	13	13	14	14	22	22
Power supply		V-ph-Hz	230 - 1 - 50							
no. of poles			4	6	4	6	4	6	4	6
Air flow rate max cooling		m ³ /h	898	898	808	808	718	718	1602	1602
Heating capacity	(1)	kW	7,87	7,87	10,0	10,0	11,2	11,2	13,4	13,4
Water flow	(1)	l/h	695	695	884	884	988	988	1184	1184
Water pressure drop	(1)	kPa	18	18	13	13	10	10	9	9
Total cooling capacity	(2)	kW	2,30	2,30	2,82	2,82	3,15	3,15	3,61	3,61
Sensible cooling capacity	(2)	kW	1,81	1,81	2,23	2,23	2,45	2,45	3,08	3,08
Water flow	(2)	l/h	395	395	482	482	541	541	620	620
Water pressure drop	(2)	kPa	9	9	6	6	5	5	4	4
Sound power level	(3)	dB(A)	53	54	53	54	54	55	58	59
Power input	(4)	W	33	34	33	34	33	34	95	81

AREO C			23	23	24	24	32	33	34	42
Power supply		V-ph-Hz	230 - 1 - 50							
no. of poles			4	6	4	6	4	4	4	4
Air flow rate max cooling		m ³ /h	1411	1411	1373	1373	2485	2292	2237	3738
Heating capacity	(1)	kW	17,3	17,3	19,1	19,1	22,9	25,4	29,1	35,1
Water flow	(1)	l/h	1527	1527	1686	1686	2024	2242	2569	3098
Water pressure drop	(1)	kPa	15	15	5	5	5	5	8	7
Total cooling capacity	(2)	kW	5,00	5,00	5,23	5,23	5,72	7,22	9,65	9,72
Sensible cooling capacity	(2)	kW	3,91	3,91	4,20	4,20	5,23	6,12	7,50	7,85
Water flow	(2)	l/h	860	860	898	898	982	1239	1656	1668
Water pressure drop	(2)	kPa	7	7	2	2	1	1	4	2
Sound power level	(3)	dB(A)	63	60	59	60	63	63	64	62
Power input	(4)	W	95	81	95	81	153	153	153	400

AREO C			43	44	63	64
Power supply		V-ph-Hz	230 - 1 - 50			
no. of poles			4	4	6	6
Air flow rate max cooling		m ³ /h	3467	3359	4232	4125
Heating capacity	(1)	kW	39,2	43,9	48,0	64,7
Water flow	(1)	l/h	3460	3875	4240	5715
Water pressure drop	(1)	kPa	7	3	8	8
Total cooling capacity	(2)	kW	12,4	13,1	18,9	22,4
Sensible cooling capacity	(2)	kW	8,69	10,3	14,3	16,8
Water flow	(2)	l/h	2123	2255	3237	3853
Water pressure drop	(2)	kPa	3	1	4	4
Sound power level	(3)	dB(A)	61	62	56	58
Power input	(4)	W	400	400	335	335

(1) Water temperature 85°C / 75°C, air temperature 15°C - max speed available in cooling mode

(2) Water temperature 7°C / 12°C, air temperature dry bulb 27°C, wet bulb 19°C (47% relative humidity) - max speed available in cooling mode

(3) Sound power measured according to standards ISO 3741 - max speed available in cooling mode

(4) Referred to max speed available in cooling mode

All data reported in the table above refer to maximum allowed ventilation speed in order to avoid the drag of the condensation drops generated in the heat exchanger.

RATED TECHNICAL DATA AREO H - HEATING MODE

AREO H			13	13	23	23	33	33	33	43
Power supply		V-ph-Hz	230 - 1 - 50	230 - 1 - 50	230 - 1 - 50	230 - 1 - 50	230 - 1 - 50	400 - 3 - 500	400 - 3 - 500	230 - 1 - 50
no. of poles			4	6	4	6	4	4	6	4
Motor connections			Mono	Mono	Mono	Mono	Mono	Delta	Star	Mono
Rated air flow		m ³ /h	1083	855	2499	1758	3943	3800	2755	6080
Heating capacity	(1)	kW	10,2	8,89	21,3	17,3	33,2	32,5	26,9	50,4
Water flow	(1)	l/h	905	785	1882	1529	2935	2871	2376	4454
Water pressure drop	(1)	kPa	13	10	19	13	12	11	8	25
Sound power level	(2)	dB(A)	64	59	76	65	74	76	69	75
Power input		W	69	50	210	114	340	330	180	635

(1) Water temperature 85°C / 75°C, air temperature 15°C - 100% of the max speed

(2) Sound power measured according to standards ISO 3741 - 100% of the max speed

AREO H			43	43	53	53	53	63	63	63
Power supply		V-ph-Hz	400 - 3 - 500	400 - 3 - 500	230 - 1 - 50	400 - 3 - 500	400 - 3 - 500	230 - 1 - 50	400 - 3 - 500	400 - 3 - 500
no. of poles			4	6	6	4	6	6	6	8
Motor connections			Delta	Star	Mono	Delta	Star	Mono	Delta	Star
Rated air flow		m ³ /h	6223	5035	5890	7505	6128	8100	7885	6175
Heating capacity	(1)	kW	51,1	45,2	56,2	64,8	57,5	99,7	80,5	69,2
Water flow	(1)	l/h	4512	3991	4960	5720	5079	8802	7106	6112
Water pressure drop	(1)	kPa	25	20	16	20	16	29	19	15
Sound power level	(2)	dB(A)	77	70	69	76	72	70	71	66
Power input		W	690	465	375	732	775	560	575	380

(1) Water temperature 85°C / 75°C, air temperature 15°C - 100% of the max speed

(2) Sound power measured according to standards ISO 3741 - 100% of the max speed

DIMENSIONAL DRAWINGS

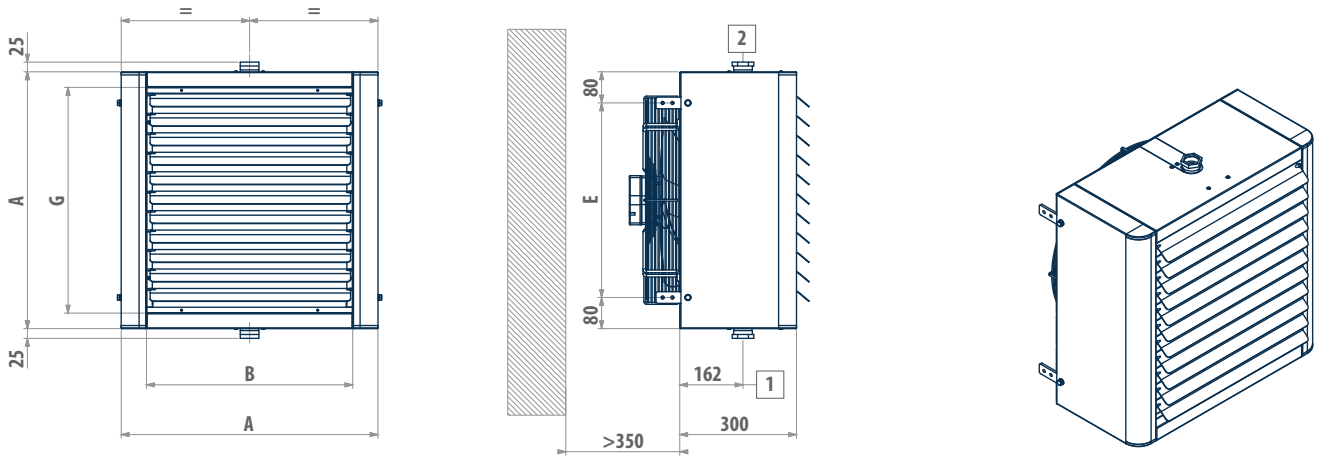
AREO H

LEGEND

- | | |
|---|------------------------------------|
| 1 | Water inlet connection female gas |
| 2 | Water outlet connection female gas |

AREO H	A mm	B mm	E mm	G mm	1 "	2 "	⚖ kg
13	460	330	300	380	1 1/4	1 1/4	20
23	560	430	400	480	1 1/4	1 1/4	26
33	660	530	500	580	1 1/4	1 1/4	35
43	760	630	600	680	1 1/4	1 1/4	41
53	860	730	700	780	1 1/4	1 1/4	52
63	960	830	800	880	1 1/4	1 1/4	61

DIMENSIONAL DRAWINGS

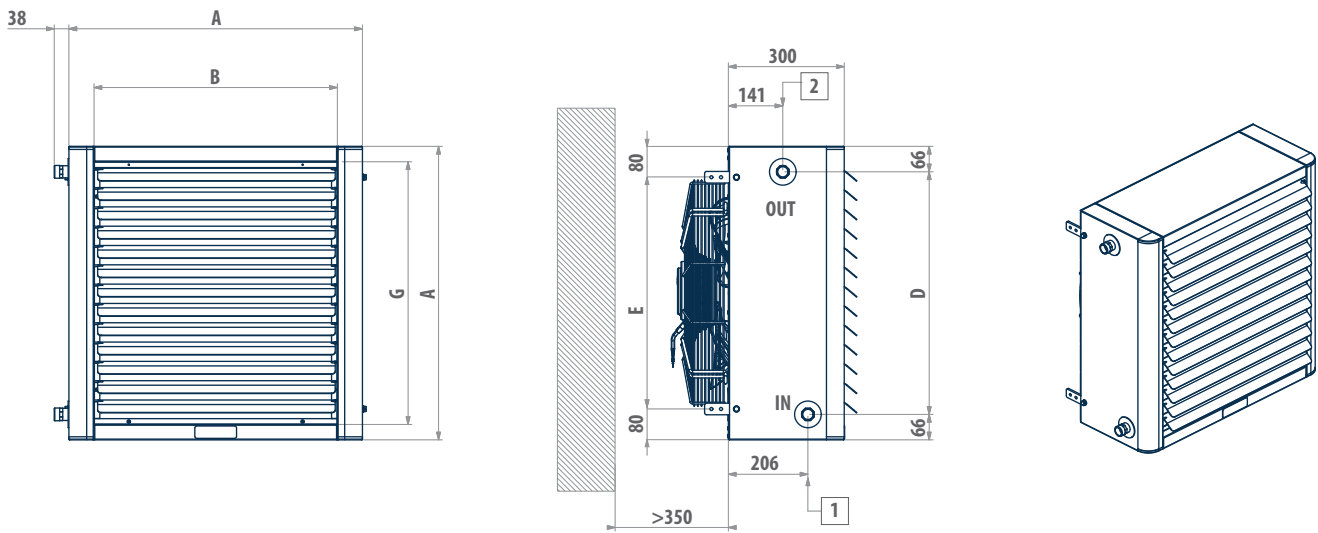
AREO P - AREO L



LEGEND

- | | |
|---|----------------------------------|
| 1 | Water inlet connection male gas |
| 2 | Water outlet connection male gas |

AREO P	A	B	D	E	G	1	2	kg
	mm	mm	mm	mm	mm	"	"	
12	460	330	328	300	380	3/4	3/4	20-20-21
13 - 14	460	330	329	300	380	3/4	3/4	20-20-21
22 - 23 - 24	560	430	428	400	480	3/4	3/4	26-26-27
32 - 33 - 34	660	530	528	500	580	1	1	34-35-37
42 - 43 - 44	760	630	628	600	680	1	1	40-41-44
53 - 54	860	730	728	700	780	1 1/4	1 1/4	52-55
63 - 64	960	830	828	800	880	1 1/4	1 1/4	61-64

AREO L	A	B	D	E	G	1	2	kg
	mm	mm	mm	mm	mm	"	"	
32 - 33	660	530	528	500	580	1	1	34-35
42 - 43	760	630	628	600	680	1	1	40-41
53	860	730	728	700	780	1 1/4	1 1/4	52
63	960	830	828	800	880	1 1/4	1 1/4	61

DIMENSIONAL DRAWINGS

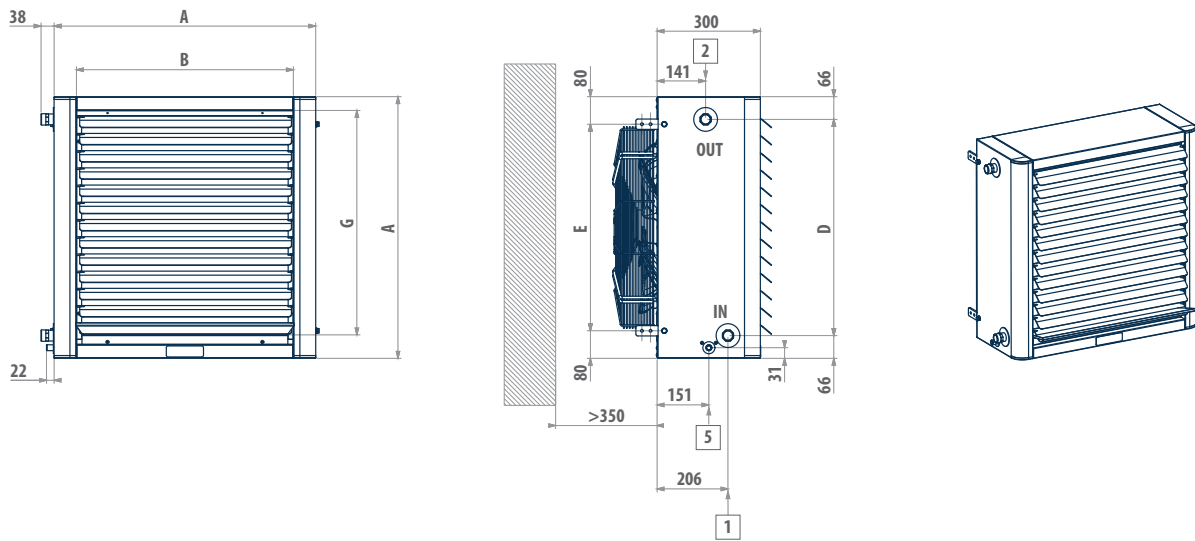
AREO C

LEGEND

1	Water inlet connection male gas
2	Water outlet connection male gas
5	Condensate drainage \varnothing 17 mm

AREO C	A mm	B mm	D mm	E mm	G mm	1 "	2 "	E mm	kg
12 - 13 - 14	460	330	328	300	380	3/4	3/4	20-20-21	
22 - 23 - 24	560	430	428	400	480	3/4	3/4	26-26-27	
32 - 33 - 34	660	530	528	500	580	1	1	34-35-37	
42 - 43 - 44	760	630	628	600	680	1	1	40-41-44	
63 - 64	960	830	828	800	880	1 1/4	1 1/4	61-64	

Fan heaters AREO i

Air conditioning fan heaters with EC motor

AREO i 19 - 62 kW



EC Motor



2 pipes systems



Vertical installation



Heating



Cooling

Reliability and energy efficiency at the top of its category

The new AREO i series combines the reliability and sturdiness of the on/off version with the innovation of Inverter technology. The AREO i series is equipped with brushless inverters (EC) integrated with the motor, which guarantees accurate adjustment of the rotation speed and maximum adaptability to real-time thermal load.

Innovative Inverter technology makes it possible to achieve an exceptional degree of aerodynamic efficiency and a consequent reduction in seasonal power consumption of up to 50% in comparison to the traditional version with AC motor.

The rounded shape of the cabinet gives the product an especially unique design.

The AREO i range consists of 8 models to be wall mounted. AREO i is ideal for both heating and cooling due to an innovative system for collecting condensate and additional insulation inside the cabinet.

The range includes 3 different construction sizes that are also available with 4-row heat exchangers to allow proper operation with hot water produced by the heat pump.

PLUS

- » Low sound levels
- » Wide operating range (up to 65 °C intake air)
- » Electric motor, class F, approved for continuous operation
- » Fan and motor are integrated to provide considerably increased reliability



ACCESSORIES

Electronic microprocessor control panels with display

DIST MY COMFORT controller spacer for wall mounting

MCLE Microprocessor control with display MY COMFORT LARGE

MCSWE Water sensor for MYCOMFORT and EVO controllers

Power interface and regulating louver controllers

CSD Recess mounted controller for opening and closing the SM motor-driven regulating louver

Accessories

VA Auxiliary tray for collecting condensate

Fixation templates

DFC Template for column installation

DFO Adjustable template for wall/column installation

DFP Template for wall installation

Protective grill for gyms (ball shield)

R Protective net for gyms

Diffusors

DO Two-row adjustable fin diffuser

External air intake

PAE External air intake

PAEM Manual mixing louver

PAEMM Motor driven mixer louver, 24 V power supply with spring return

External air intake rain protection grille

GR Air intake grille with subframe

MAIN COMPONENTS
Fan drive assembly

The electric fan and EC motor are a single integrated unit optimized to achieve maximum aeraulic efficiency. In fact, conformity to ERP is guaranteed, even for the versions with single-phase power supply.

Electric motor

Tropicalized motor directly coupled to an external rotor, standard, with the following features:

- equipped with internal thermal protection
- windings in class F
- protection rating IP54

Axial fan

With blades with an optimized aerodynamic profile, statically balanced, inserted in a housing that enhances aeraulic performance and minimizes noise.

Microprocessor controller (accessory)

The advanced microprocessor control unit adjusts the fan speed of the brushless motor between 0 and 100%, so that in all partial load conditions the indoor unit will operate at a reduced speed with considerably reduced noise emissions and power consumption.

Cabinet

Pre-painted steel sheet cabinet complete with ABS corner trims, adjustable aluminium louvers (spring-operated) placed on the air outlet which enable an optimal distribution of air within the room to be heated.

Heat exchanger

High conductivity heat exchanger made with copper piping and aluminium fins assuring higher heat exchange than standard iron piping exchangers.

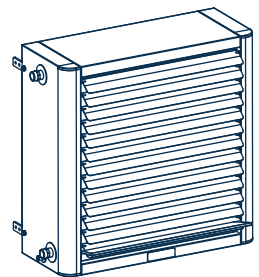
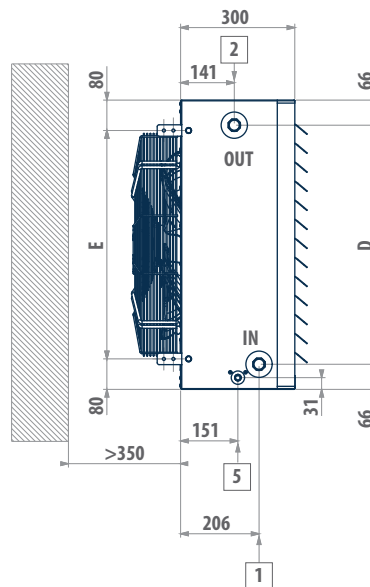
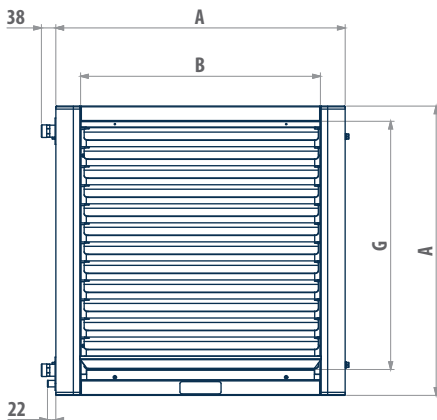
DIMENSIONAL DRAWINGS
AREO i

LEGEND

- | | |
|---|-----------------------------------|
| 1 | Water inlet connection, male gas |
| 2 | Water outlet connection, male gas |
| 3 | Condensate discharge Ø 17 mm |

AREO i	A	B	D	E	G	1	2	📦 kg
	mm	mm	mm	mm	mm	"	"	
33MDF - 34MDF	660	530	528	500	580	1	1	33-34-36
43MDF - 43TDC	760	630	628	600	680	1	1	39-41-42
63MDF - 63TDF - 63MDC - 63TDC	960	830	828	800	880	1 1/4	1 1/4	58-61-63

Fan heaters AREO i

RATED TECHNICAL DATA - HEATING MODE

AREO i			33MDF	34MDF	43MDF	43TDC	63MDC	63MDF	63TDC	63TDF
Power supply		V-ph-Hz	230-1-50	230-1-50	230-1-50	400-3-50	230-1-50	230-1-50	400-3-50	400-3-50
Air flow rate max heating		m ³ /h	3400	3255	5575	7606	9006	7449	10734	8282
Heating capacity	(1)	kW	19,0	22,3	31,0	36,4	59,9	56,2	68,6	62,2
Water flow	(1)	l/h	1664	1954	2719	3183	5249	4921	6005	5448
Water pressure drop	(1)	kPa	5	9	12	16	13	11	16	13
Sound power level	(2)	dB(A)	77	79	76	80	78	75	84	83
Power input	(3)	W	189	193	388	918	693	414	1001	655

- (1) Water temperature 65°C / 55°C, air temperature 15°C - 100% of the max speed
 (2) Sound power measured according to standards ISO 3741 - 100% of the max speed
 (3) Referred to maximum speed

RATED TECHNICAL DATA - COOLING MODE

AREO i			33MDF	34MDF	43MDF	43TDC	63MDC	63MDF	63TDC	63TDF
Power supply		V-ph-Hz	230-1-50	230-1-50	230-1-50	400-3-50	230-1-50	230-1-50	400-3-50	400-3-50
Air flow rate max cooling		m ³ /h	2601	2414	3848	4164	5746	4107	6173	4471
Heating capacity	(1)	kW	16,3	18,9	25,0	25,8	45,6	38,5	49,1	42,0
Water flow	(1)	l/h	1426	1653	2192	2261	3992	3367	4295	3675
Water pressure drop	(1)	kPa	4	7	8	9	8	6	9	7
Total cooling capacity	(2)	kW	5,83	9,65	12,2	13,4	21,1	19,4	25,9	23,9
Sensible cooling capacity	(2)	kW	4,63	6,66	8,32	9,14	13,7	12,7	17,1	15,7
Water flow	(2)	l/h	1016	1672	2120	2332	3661	3367	4509	4124
Water pressure drop	(2)	kPa	3	9	8	9	9	6	9	11
Sound power level	(3)	dB(A)	73	72	68	70	71	68	78	72
Power input	(4)	W	86	92	139	177	219	103	363	131

- (1) Water temperature 65°C / 55°C, air temperature 15°C - max speed available in cooling mode
 (2) Water temperature 7°C / 12°C, air temperature dry bulb 28°C, wet bulb 19°C (53% relative humidity) - max speed available in cooling mode
 (3) Sound power measured according to standards ISO 3741 - max speed available in cooling mode
 (4) Referred to max speed available in cooling mode

Air destratifiers

DST 1700 - 9100 m³/h

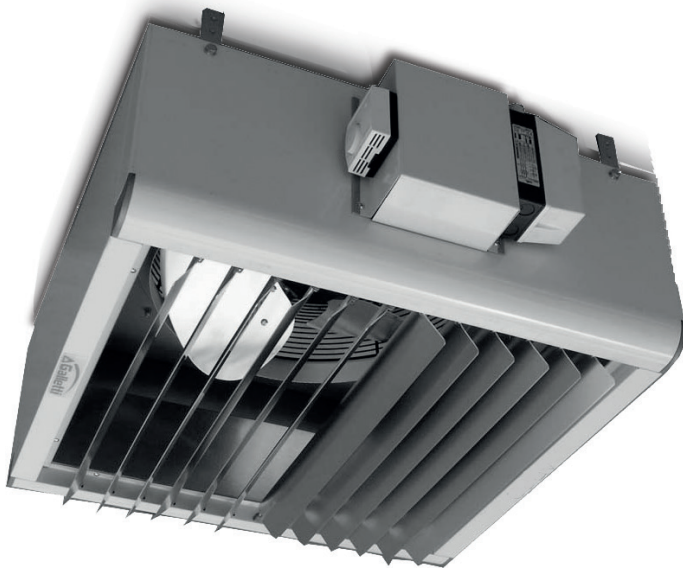

Horizontal installation



Axial fan

PLUS

- » Simple installation
- » Overload cut-out and safety thermostat are standard
- » Adjustable louvers
- » HyBlade® axial fans

The solution for eliminating hot air stratification in industrial environments

In industrial environments characterized by high ceilings and heating with hot air systems, the need to maintain a comfortable temperature at the floor level for the personnel results in the inconvenience of concentrating high-temperature air in the upper part of the area. Therefore, the heat remains trapped and unused near the roof and it is destined to be lost outdoors, thus increasing the building's heat loss.

The DST series air destratifiers eliminate this problem, generating a descending vertical air flow that is able to reduce the difference in temperature of the air between the floor and the ceiling up to a maximum of approximately 3 °C. During the summer months the DST air destratifiers can be used to achieve effective ventilation. They are equipped with a fan drive unit consisting of axial fans and asynchronous, single-phase, and three-phase electric motors depending on the size, with external rotor, which guarantees compatibility with the most recent regulations on limiting energy consumption.

The safety thermostat and the magnetothermic motor protection device with manual reset, installed in the unit as standard equipment, together with the convenient mounting brackets and baffles that can be adjusted to direct the air flow, make installation particularly easy without the use of further accessories.



MAIN COMPONENTS
Fan drive assembly

The axial fan, with Hyblade® type airfoil blades made of aluminum and coated with plastic material, possesses the unique characteristics of both materials: sturdiness and quietness are combined with a highly efficient asynchronous electric motor with external rotor.

Fan stop thermostat

It is installed on the unit and allows the temperature to be set at which destratifier operation is activated.

Structure

Pre-painted sheet steel structural work equipped with ABS and adjustable aluminum baffles.

RATED TECHNICAL DATA

DST		14	26	36	46	56	66
Fan speed	rpm	1400	900	900	900	900	750
Rated air flow	m ³ /h	1710	3083	4199	7220	8142	9139
Minimum installation height	m	3,00	3,50	4,50	5,00	7,00	6,50
Maximum installation height	m	5,00	5,50	7,00	7,50	9,00	10,0
Power supply	V-ph-Hz	230 - 1 - 50	230 - 1 - 50	400 - 3 - 50	400 - 3 - 50	400 - 3 - 50	400 - 3 - 50
Power input	W	62	110	160	390	418	320
Absorbed current	A	0,30	0,50	0,30	0,70	0,70	0,60
Sound power level	(1) dB(A)	65	68	72	76	78	70

(1) Sound power measured according to standards ISO 3741

DIMENSIONAL DRAWINGS

DST

DST	A	B	C	D	E
	mm	mm	mm	mm	mm
14	460	300	350	300	500
26	560	400	450	400	500
36	660	500	550	500	525
46	760	600	650	600	515
56	860	700	750	700	535
66	960	800	850	800	535



CO - CONTROLLERS AND SOFTWARE FOR HYDRONIC INDOOR UNITS

Introduction	p.152
EVO-2-TOUCH	p.156
EVO	p.158
EVO DISP	p.159
GALLETTI APP	p.160
MYCOMFORT	p.162
TED	p.164
EVO LINK	p.165



Galletti adjustment



Air-conditioning control is now quick and easy: effective room comfort is efficiently, simply, and intuitively accessible with Galletti control panels, from the simplest electromechanical control for setting the fan speed to microprocessor controls for complete temperature and humidity control.

Both ON/OFF and modulating 2- and 3-way valves are managed according to the temperature and humidity values measured.

Controls that can be integrated into any type of system



The wide range of Galletti controllers offers a multitude of installation options.

No fewer than 7 controls designed for on-board installation guarantee simple and elegant solutions. Specific installation kits allow mounting in the ESTRO, FLAT hydronic indoor units. This gives users control of the temperature at their fingertips and a solution that can be integrated in any type of environment.

There is now an even wider range of wall-mounted controllers: 9 controls with the option to manage, from a single point, more than one indoor unit in the same room.

In addition to these, an infrared remote control is also available for high wall-mounted indoor units and cassette fan coil units.

Controls of every level for any need



Galletti's offering is suitable for every need of cost-effectiveness and functionality. With its 9 electromechanical controls and its 5 microprocessor controls, Galletti is a market leader due to the diversity of its range of products. The devices offered in its catalogue are capable of interacting with multiple-speed indoor units or with modulating ventilation managing various different dynamics of thermostatisation and any serial communication.

Serial Communication: different possibilities for different needs

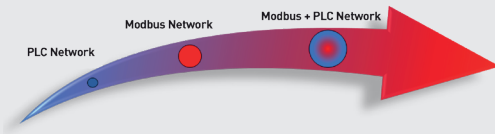

Galletti offer of RS485 serial port microprocessor controls, allows a suitable single terminal management, literally opening the doors to every plant adjustment need. The circulation of information on a bus-type network via Modbus communication protocol, standard in the HVAC field, is completed and combined with Power Line Communication (PLC), enabling a customised and easier interaction between user and plant.

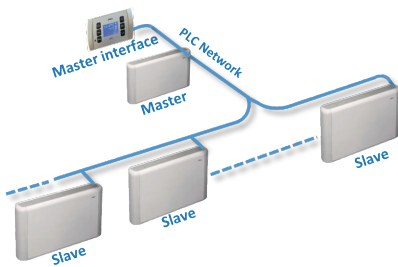

Power Line Communication (PLC) Network

» **Easy installation**

- » Single interface to control multiple units
- » Electrical wires reduction
- » Slave units repeat exactly Master unit instructions
- » Suitable solution for terminal units submitted to the same thermal charge
- » Available with EVO controller

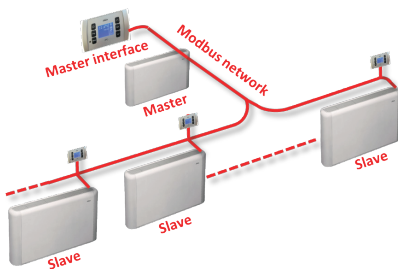

Modbus Network

» **Suitable solution for terminal units submitted to different charges**

- » Each unit is equipped with its own sensors
- » Master unit sets the main parameters
- » Multiple degrees of freedom settable for Slave units
- » Available with MYCOMFORT or EVO controllers

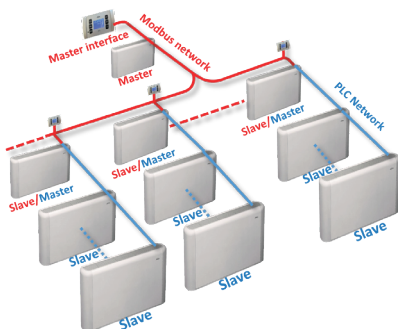

Mixed Network

» **Ideal solution for hotels or places with multiple zones to be conditioned**

- » Key areas controlled via Modbus protocol and replica of the same instructions via Power Line Communication (PLC)
- » Master unit can be a simple controller or a more complex supervision system
- » Monitoring with decreasing degree of autonomy
- » Contemporary use of Modbus Network and Power Line Communication (PLC) with both advantages
- » Available with EVO controller

Controllers and software for indoor hydronic units

Overview page of controls for hydronic indoor units

The following table can be used to quickly identify the most suitable control panel according to the functionality required.

		ELECTROMECHANICAL CONTROLLERS			MICROPROCESSOR CONTROLLERS		
		CB	TIB	TA2	TED2T	TED4T	TED10
Installation	On-board	✓	✓	–	✓	✓	✓
	Wall	–	–	✓	✓	✓	✓
System	2 pipes	✓	✓	✓	✓	–	✓
	4 pipes	–	–	–	–	✓	✓
Adjustment	Air thermostat	–	✓	✓	✓	✓	✓
	3 speeds	✓	✓	–	✓	✓	✓
	4 speeds	–	–	–	–	–	–
	Automatic speeds	–	–	–	–	–	✓
	Variable speed	–	–	–	–	–	✓
	Dehumidification / RH reading	–	–	–	–	–	–
External sensors	Water sensor	–	–	–	✓	✓	✓
	Remote air sensor	–	–	–	✓	✓	✓
	Remote RH sensor	–	–	–	–	–	–
	Water operating thermostat	✓	✓*	–	–	–	–
External devices management	ON/OFF valve management	–	✓*	✓	✓	✓	✓
	Modulating valve management	–	–	–	–	–	–
	Control of heating element	–	–	–	–	–	–
	Digital outputs	–	–	–	–	–	–
Ancillary functions	Summer/Winter local	–	✓	✓	✓	✓	✓
	Summer/Winter water	–	–	–	–	–	–
	Summer/Winter air (4 pipes)	–	–	–	–	✓	✓
	Economy	–	–	–	–	–	–
	Digital inputs	–	–	–	–	–	–
	Modbus communication	–	–	–	–	–	–

✓* options that are not mutually compatible



Overview page of controls for hydronic indoor units

The following table can be used to quickly identify the most suitable control panel according to the functionality required.

MICROPROCESSOR CONTROLLERS WITH DISPLAY

MYCOMFORT BASE	MYCOMFORT LARGE	EVO2TOUCH	EVO
----------------	-----------------	-----------	-----



		MYCOMFORT BASE	MYCOMFORT LARGE	EVO2TOUCH	EVO
On-board	Installation	✓	✓	✓**	✓**
Wall		✓	✓	✓	✓
2 pipes	System	✓	✓	✓	✓
4 pipes		✓	✓*	✓	✓
Air thermostat	Adjustment	✓	✓	✓	✓
3 speeds		✓	✓	✓	✓
4 speeds		✓	✓	✓	✓
Automatic speeds		✓	✓	✓	✓
Variable speed		—	✓*	✓	✓
Dehumidification / RH reading		—	✓	✓	✓
Water sensor	External sensors	✓	✓	✓	✓
Remote air sensor		✓	✓	✓	✓
Remote RH sensor		—	✓	✓	✓
Water operating thermostat		—	—	—	—
ON/OFF valve management	External devices management	✓	✓	✓	✓
Modulating valve management		—	✓*	✓	✓
Control of heating element		✓	✓	✓	✓
Digital outputs		—	✓	✓	✓
Summer/Winter local	Ancillary functions	✓	✓	✓	✓
Summer/Winter water		✓	✓	✓	✓
Summer/Winter air (4 pipes)		✓	✓	✓	✓
Economy		✓	✓	✓	✓
Digital inputs		✓	✓	✓	✓
Modbus communication		—	✓	✓	✓
JONIX management		✓	✓	✓	✓

✓* options that are not mutually compatible
 ✓** ART-U

Touch screen display interface



EVO-2-TOUCH

to combined with EVOBOARD

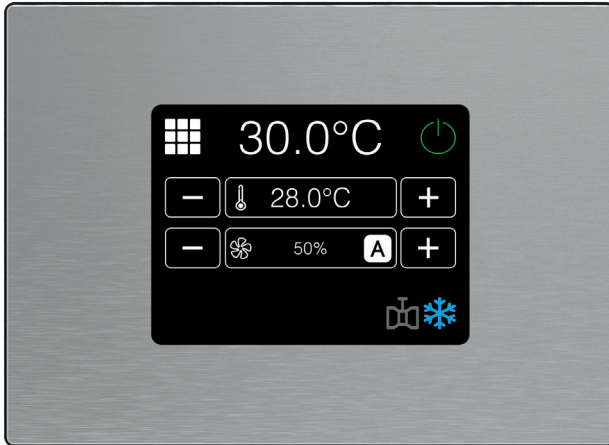

PLUS

- » 2.8" capacitive touch screen display
- » Integrated temperature and humidity probe
- » Low-voltage power supply drawn from the power component
- » Wall mounted or ART-U on-board installation
- » Designed for the main electrical connection boxes
- » User-friendly
- » Aluminium foil and polyethylene frame with various chrome plating options

FEATURES



Intelligent interface

The various screens are designed to make human-machine communication intuitive. Each page contains a few essential items of information that allow the consultation of the unit's main operating parameters and enable the initial control configuration according to system requirements.

Smart touch

Touch screen technology is another element whose goal is to simplify the user experience. The tap and swipe functions make the control experience similar to that of your smartphone.

INSTALLATION

Installation procedures

The touch screen interface can be installed in the ART-U series in combination with the EVO BOARD circuit board, integrating all the advanced functions of EVO with a strongly design-oriented product. The different colour combinations of the frame, combined with the different versions of the cover panel of the ART-U series, allow considerable freedom of customisation. If envisaged to be combined with other series of fan coil units, the preparation for the main standard electrical boxes allows easy mounting on the wall. In this case the clips positioned at both ends of the containment box allow the correct reading of the room temperature by the sensor integrated in the control electronics

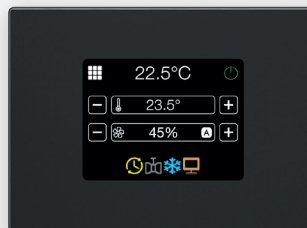
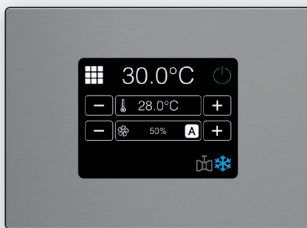
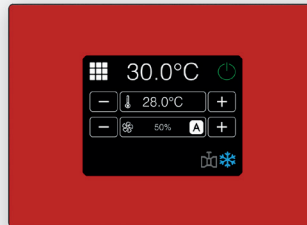
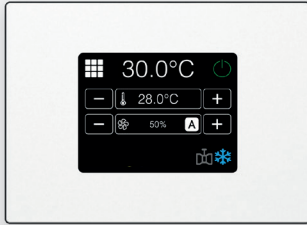

COLOUR OPTIONS

Customisable frame

The external frame of the interface is available in four different chrome plating options and is made with double aluminium foil and a polyethylene core. The available colours are white, black, grey, and red, and allow the ideal combination with the versions of the ART-U series. In the case of wall mounting, the various solutions represent a good range of choice for determining the best match with the style of the structure to be air-conditioned.

FUNCTIONS
“Economy”

A typical need in hotel rooms and in other rooms with variable occupancy is the management of air conditioning with reduced operation when the user is not present. This solution, which is often accomplished by means of occupancy sensors or magnetic readers, guarantees considerable energy savings, but requires the possibility to force the fan coil unit to operate in Economy mode in a simple and effective manner. This is all possible with EVO, which has 3 pre-configured digital inputs for ON/OFF, Economy mode, and remote summer/winter switchover.

Lock function

On all the interfaces that can be combined with the EVO BOARD circuit board, it is possible to force the locking of the control functions in order to avoid unwanted changes to the fan coil unit's operating and configuration parameters. This function is activated with a keyboard shortcut or by entering passwords depending on the interface chosen.

Configurable digital output

EVO is equipped with a fully configurable digital output that allows the control to provide important information to external devices, such as the cooling and/or heating demand, the operating mode, and the possible presence of an alarm.

Activation of external dehumidifier/humidifier

This control implements the humidity control function in relation to a settable setpoint. By connecting the appropriate sensor to the control it is possible to not only vary the fan coil unit's adjustment dynamics, but also manage the calls to external devices such as humidifiers and dehumidifiers.

Electronic microprocessor control

EVO

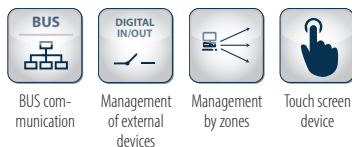
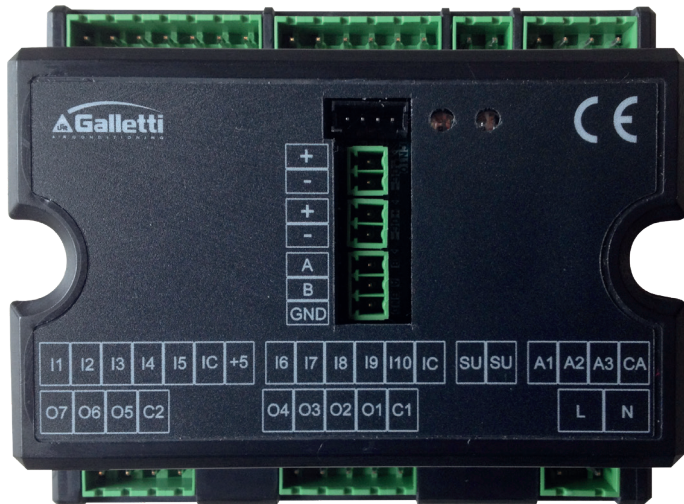

Intuitive and user-friendly multi-purpose regulator

EVO encompasses the best of Galletti adjustment with regard to hydronic indoor units.

The EVO software, which was developed entirely by Galletti's Technical Department, consists of two distinct parts in two microprocessors. The first of these, resident on the power board, manages the monitoring of the parameters and the adjustment logics. The second part of the software, which is loaded on the user interface microprocessor, guarantees true communication, by means of which the installer and the user are guided in the configuration and use of the controller.

If on-board installation of the power board is requested, which is an option that is available for the majority of Galletti hydronic indoor units, during the wiring phase you just need to connect the user interface using a two-core shielded cable. This extraordinary simplicity cuts installation time and costs in half.

The EVO controller has been designed to govern the operation of Galletti indoor units with single-phase multispeed asynchronous motor or modulating speed EC motors. Specifically, its advanced technology makes it possible to establish control networks that are suited to meet any need, for automatic and intelligent management of the system's indoor units.

PLUS

- » Considerable savings in the installation phase
- » User-friendly interface
- » RS485 and OC serial communication
- » Advanced de-humidifying function
- » Simultaneous control of 3 modulating devices
- » Advanced control of time schedules
- » LCD display or touch screen

Multi-interface control

EVO is characterized by the possibility of combining the power module with different types of interfaces, adopting each time the best solution for different installation needs.

If an interface is not required, the unit can be directly connected to one's smartphone using the Galletti app (after pre-configuring the circuit board).

Split solution

The separation between power elements and graphic interface is a very practical solution from the point of view of installation, with the advantage of supplying low voltage to the interface in contact with the user and using a single cable for both power supply and information exchange between the two devices. This considerably reduces the length and cost of the cables to be laid, thus avoiding any additional cost for the end user.

ACCESSORIES

Electromechanical control panels

IPM Circuit board for connection of UTN 30-30A-40-40A to control panels.

Electronic microprocessor control panels with display

MCSUE

Humidity sensor for MY COMFORT (large), EVO

MCSWE

Water sensor for MYCOMFORT and EVO controllers

User interface with LCD display

EVO DISP



to combined with EVOBOARD

PLUS

- LCD display with integrated temperature probe
- Low-voltage power supply drawn from the power component
- Wall mounted or ART-U on-board installation
- Designed for a 503 electrical enclosure
- Customisable stand-by mode
- Keypad lock function

LCD display

The control panel connects directly to the circuit board installed on the fan coil unit from which the low-voltage power supply is drawn. The interface is designed to be installed on standard electrical boxes and is designed to house a probe for reading relative humidity. Its real-time clock (RTC) allows the fan coil unit to be managed by setting time bands.



Automatic control of time slots

The user interface makes it possible to set the ON/OFF status of the control and the desired set-point, on an hourly basis, for the different days of the week. If the above-mentioned operating parameters are set on a master unit, they can be replicated on all the connected slaves.



Modulating devices control

EVO is capable of simultaneously controlling up to two modulating valves and one BLDC fan, making it possible to vary the air flow rate and the water flow rate in the heat exchanger, adapting to the thermal load.

Humidity control

EVO offers the possibility of automatically activating a dehumidification process depending on the relative humidity and a settable setpoint. This function requires a humidity sensor that is available as an accessory.

Serial communication

The controller has serial ports for RS485 communication and power-line communication that allow the development of control networks that are adequate for every need.

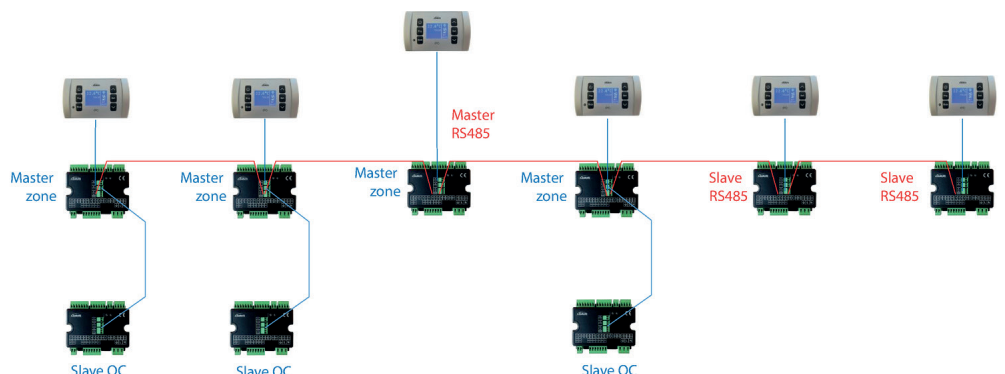

Controllers and software for indoor hydronic units - EVO

Indoor unit control application for smartphones

GALLETTI APP



Wi-Fi



Bluetooth



Touch screen device

PLUS

- » Wi-Fi or Bluetooth communication
- » Information always accessible in the cloud
- » Remote access
- » IOS- and Android-compatible application
- » Can be used with all indoor units governed by EVO

FUNCTIONS AND FEATURES

Navel

It is the device used to enable Wi-Fi or Bluetooth communication between EVO BOARD and the smartphone on which the Galletti application is present. It is to be placed on the side of the fan coil unit and draws power directly from EVO.

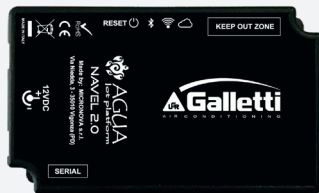

Communication

Two possible communication alternatives are available: Wi-Fi or Bluetooth. In the first case information is sent to the cloud and any device using the application can consult or change the settings wherever an internet connection is available. The second mode is the stand-alone mode; it is capable of transforming a smartphone into a remote control for the fan coil unit.

Universal remote control

All the advanced EVO control functions are present in the application, which is therefore able to activate/deactivate dehumidification cycles, activate the minimum temperature function, and activate or deactivate the time bands that define the switching on and off of the devices.



Diagnostic information

The application makes available information about the status of the fan coil unit and some accessories that are currently connected. Among other things, it is possible to evaluate the opening/closing status of the valve, the water supply temperature, and the possible presence of an alarm in the air temperature probe reading.

Compatibility

The possibility of combining the Navel accessory with the EVOBOARD circuit board makes the application suitable for controlling all the indoor units in the catalogue that do not already have the possibility of infrared remote control. Within the application it is possible to create a customised list of indoor units that can be quickly accessed.

ACCESSORIES

EVO-2-TOUCH EVOBOARD 2.8" touch screen user interface for EVO control
Circuit board for EVO control

EVODISP EYNAVEL User interface with display for EVO controller
Device for Wi-Fi or Bluetooth communication between EVOBOARD and smartphone

EVO-LUTION

GALLETTI APP



EVO BOARD



EVO DISP



EVO-2-TOUCH

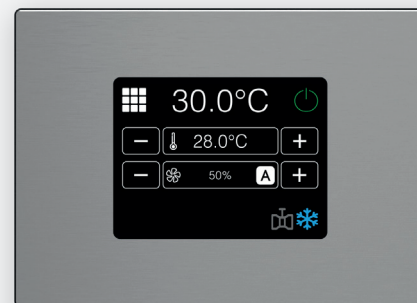

Controllers and software for indoor hydronic units - GALLETTI APP

Electronic microprocessor controller with LCD display

MYCOMFORT



Two different proposals for a customized level of comfort

Climate control becomes fast and simple: interior comfort conditions can be controlled thanks to the new MYCOMFORT control panels, the connection node of Galletti integrated systems.

The microprocessor control panel allows you to set the operating mode of the indoor hydronic units in such a way as to achieve conditions of interior comfort and complete control over the air conditioning system.

The controller features a large-sized liquid crystal display with incorporated keypad for setting and reading environmental parameters and the operating parameters of the indoor unit connected to it.

There is a vast choice of accessories available, which allow either wall mounting or installation on board the indoor unit.



BUS communication



Management of external devices

PLUS

- » Two versions depending on the customer's requirements
- » Large display
- » User-friendly interface
- » Wall mounted or on-board installation
- » Easy connection and startup



AVAILABLE VERSIONS

BASE

Temperature-based control of fan coil (4 fan speeds) unit and regulating valves.

LARGE

Control of fan coil unit (4 fan speeds) and regulating valves based on temperature, humidity, weekly timer, connection to supervision systems, setting up of small networks in master mode, backlit display, control of modulating devices (valves, EC motors)

MAIN COMPONENTS AND FEATURES
Shell

The outer shell is made of ABS that has been UV treated to retain the original colour over time. Its pleasant design makes it suitable for high-grade installations in sophisticated environments.

Display

3" are available to the user to clearly view all the data of interest for efficient adjustment. The use of intuitive pictograms to represent all the functions makes it highly user friendly.

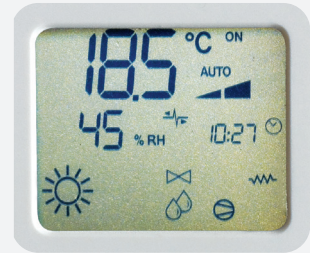
Terminal board

MYCOMFORT features quick-connect terminals which enable hassle-free wiring. Programming of the functions and address is simplified as it can be done directly from the keypad and display.

Control and savings

Automatic control of the unit's cooling and heating functions according to air and water temperatures.

Real comfort

MYCOMFORT can control and maintain comfort in terms of both temperature and humidity thanks to the presence of a sensor which measures ambient humidity and enables dehumidification cycles to be carried out by acting on valves, ventilation and the water set-point.

Management of accessories and external devices

This controller allows the management of both ON/OFF and modulating 2- and 3-way valves, and in addition it is possible to manage external devices such as chillers, boilers, and zone valves. It is performed by means of no-voltage ON/OFF contacts, depending on the environmental parameters.

Supervision

This controller can be integrated with a monitoring system, by means of the RS485 bus connection, from which it is possible to display all the functions and access to the MYCOMFORT programming menu.

MYCOMFORT FEATURE

	Base	Large
4-speed fan control	•	•
ON/OFF valve control	•	•
ON/OFF via external enable signals / digital inputs	•	•
External devices/digital outputs ON/OFF		•
Air temperature sensor	•	•
Water temperature sensor	•	•
Humidity air probe		•
BUS/RS485 connection		•
Modulating valves/0-10V outputs control		•
Inverter fans/0-10V outputs control		•
Weekly clock		•
Backlit display		•

ACCESSORIES

Electronic microprocessor control panels with display		KBFLAE	MY COMFORT on-board installation KIT for FLAT
DIST	MY COMFORT controller spacer for wall mounting	MCSUE	Humidity sensor for MY COMFORT (large), EVO
KB2X1E	MY COMFORT on-board installation KIT for 2X1	MCSWE	Water sensor for MYCOMFORT and EVO controllers
KBESTE	MY COMFORT on-board installation kit for ESTRO		

Simplified electronic controller

TED

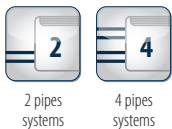

A series of three easy and efficient controllers

The three versions of the new electronic device TED, are Galletti answer to the demand of a simple and flexible controller suitable to the different plant needs.

The assignment of the operating conditions is intuitive and easy-applicable, and the supplied accessories allow the installation on board in addition to the classical on wall.

The controller is moreover equipped in all versions with dedicated contacts for both air and water probes. In this latter case it is therefore possible to consent ventilation only if water temperature is adequate to the normal operating condition.

PLUS

- » Three versions depending on plant and terminal units
- » Easy application
- » Wall mounted or on-board installation
- » Units supplied with EC electric motor supported (only 0-10 V version)



AVAILABLE VERSIONS



TED2T

- It supports terminal units equipped with asynchronous electric motor in 2 pipes plants
- ON/OFF valve supported
- Water consent on the basis of temperature



TED4T

- It supports terminal units equipped with asynchronous electric motor in 4 pipes plants
- Two ON/OFF valves supported
- Seasonal manual or automatic switch (on the basis of air temperature)
- Water consent on the basis of temperature



TED10

- It supports terminal units equipped with EC electric motor thanks to its internal 0-10 V signal generator
- Suitable for both 2 or 4 pipes plants
- Manual or automatic speed adjustment mode
- Water consent on the basis of temperature

ACCESSORIES

Electronic microprocessor control panels

KB A On-board ESTRO FA installation kit suitable for TED controller

KB F On-board FLAT/FLAT S installation kit suitable for TED controller

KB L DX On-board ESTRO FL/FU/FB installation kit on the right side suitable for TED controller

KB L SX On-board ESTRO FL/FU/FB installation kit on the left side suitable for TED controller

TED SWA Water temperature sensor for TED controls

KB-ART On-board ART-U installation kit suitable for TED controller

Controllers and software for indoor hydronic units EVO LINK

Monitoring system with 5" touch screen for the air-conditioning system

EVO LINK



EVO LINK, supervision made simple.

To provide a monitoring package that is both intuitive and powerful, EVO LINK was developed Galletti monitoring in a convenient all-in-one format. EVO LINK is an elegant but unobtrusive 5" wall-mounted tablet that contains everything necessary for monitoring a small system. With EVO LINK, a heat pump and up to 30 indoor units can be controlled with EVO controls, using cool, intuitive graphics. With EVO LINK, monitoring has never been easier: setting time slots, scheduled switching on or off, or changing your units' setpoints will be quick and convenient.



PLUS

- » Advanced logic zone management
- » Monitoring of heat pumps and multi-purpose units
- » Time schedules
- » Indoor unit auto-scanning procedure
- » Extreme simplicity of installation and of use

The simple and intuitive dashboard allows you to control all the devices in your system with just one click! Thanks to the dedicated screen, managing chillers and heat pumps has never been this easy!

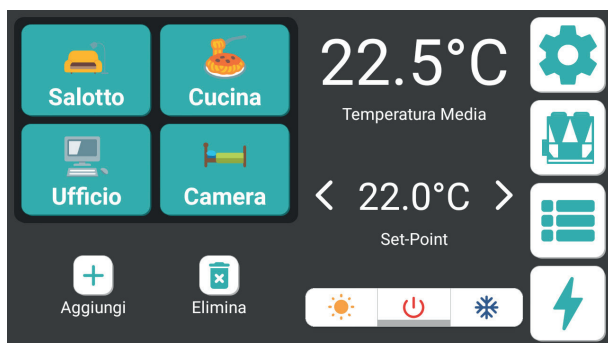

ACCESSORIES

Electronic microprocessor control panels with display	MCSWE	Water sensor for MYCOMFORT and EVO controllers
EVO-2-TOUCH		2.8" touch screen user interface for EVO control
EVOBOARD		Circuit board for EVO control
EVO DISP		User interface with display for EVO controller

Controllers and software for indoor hydronic units - EVO LINK



AW - AIR CHILLERS AND HEAT PUMPS

Introduction	p.168		
MPE	p.170	PLN	p.220
MLI	p.182	EvitechH	p.230
DLI	p.188	LCX	p.238
MLP	p.194	VLS	p.254
PLP	p.202	GLE	p.274
PLI	p.208	MTE	p.282
PLE	p.214	LRE	p.292



Air chillers and heat pumps

Range of capacities between 4 and 1200 kW to meet engineering and installation requirements.

10 different series of units, cooling only or heat pump, from which professionals can make the proper choice depending on their design and installation requirements.

The feature that all Galletti units have in common is the complete configurability of every model. The hydronic and aeraulic “plug & play” feature that allows immediate system application, the partial heat recovery from overheating for the production of hot water at the same time as operation in cooling mode, and the sophisticated controls that allow interconnection with monitoring systems using the most common protocols, are a few of the possibilities for customizing the air/water heat pumps and chillers. With Galletti, special becomes standard.



All-in-one solutions.

All Galletti air heat pumps and chillers are completely configurable on the hydronic side. Inside every unit, from 4 to 1200 kW, depending on the series, it is possible to install hydronic kits without modifying their dimensions, with the option of choosing the water circulation pump:

- » single pump, standard head or uprated (high head).
- » dual pump solution (OR): standard or uprated pump, operating singly. The pumps operate in turns on a time/fault basis. In the case, the microprocessor controls the pumps in such a way as to equally divide the hours of operation, changing over the pumps in the event of a fault.
- » dual pump solution (AND): standard or uprated pump, operating simultaneously. Connected in parallel, they deliver water at the nominal flow rate when operating simultaneously.

AEROTHERMAL ENERGY

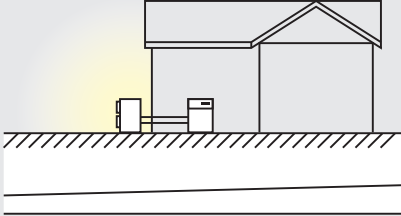

Air: a source that is always available

Galletti air/water units are characterized by a large operating range that allows them to adapt to use under any conditions. Cooling operation at full load with air temperatures up to 51 °C, which increases as a result of careful management of the step levels. During the winter period, production of water up to 65 °C and operation with external temperatures as low as -20 °C.

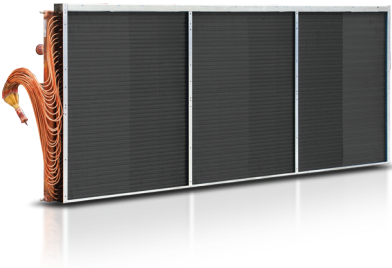

Finned block heat exchangers

They are generously sized and can use hose with a diameter of 8 mm, which reduces air side pressure drops, thereby considerably improving the unit's noise levels. The special engineering of the heat exchangers allows defrost cycles to be carried out at maximum speed in the models with heat pump operation, which brings clear benefits in terms of the integrated efficiency of the whole cycle. On request hydrophilic heat exchangers can be installed that partialize the water droplets and reduce obstruction by ice of the spaces between the fins, preventing the formation of frost at low temperatures. The finned block condensers can be fitted with a protective outer grille.

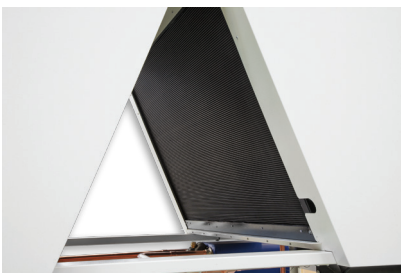

Air heat exchanger – micro-channel refrigerant coil

Micro-channel heat exchanger made of aluminium-manganese alloy fins, heads and channels made of long life alloy and copper coated user connections. Micro-channel technology together with an accurate thermodynamic project, ensure a reduced refrigerant charge up to 30 or 40% than the corresponding chillers equipped with usual condensing coils. This result appears to be extraordinary if related to the coherent choose of producing low TEWI units made by Galletti in order to reduce environmental impact in the HVAC sector.

Free-cooling

The Free-cooling units permit high energy saving when outdoor temperature is lower than the circulating fluid temperature (process industry, close control applications, information technology industry in general, congress halls, etc.). Free cooling exchanger performance depends on the difference between outdoor air temperature and circulating water temperature.

Outdoor packaged unit

MPE 4 - 76 kW



PLUS

- » Completely configurable range
- » Dual-compressor version that guarantees high efficiency at partial loads
- » Production of chilled water up to an air temperature of 47 °C
- » Built-in hydronic unit
- » Available ducted version on request
- » -

Efficiency under all operating conditions

MPE water chillers and heat pumps are designed for outdoor installation in both residential and industrial applications. The range uses R410A refrigerant, which assures high levels of performance with relatively low energy consumption and features 10 models in the chiller version and 29 models in the heat pump version, with cooling capacities ranging from 20 to 71 kW and heating capacities from 5 to 85 kW.

The finned block heat exchangers have been optimised for R410A and use 8 mm copper pipes, which permit a better heat exchange and quiet operation of the fans. Their generous sizing guarantees the production of chilled water even with outdoor air temperatures as high as 51°C.

In the MPET models, with a double compressor on the same cooling circuit, the working temperature range is extended further and efficiency at partial loads increases. In demanding working conditions the microprocessor controller activates the capacity control mode, doubling the condensing surface available to the single compressor.

The self-adaptive logic allows the setpoint to be adjusted automatically according to the outdoor temperature in order to reduce consumption and broaden the working temperature range.

The unit can also function in systems with a low water content, even without the use of a storage reservoir, thanks to the automatic adjustment which limits the number of compressor starts and thus extends the life of the compressors themselves.

The exclusive Smart Defrost System (optional feature available with the advanced controller) can correctly identify an impairment of performance in the outdoor exchanger due to the formation of ice and minimise the process time in relation to normal operation of the unit.

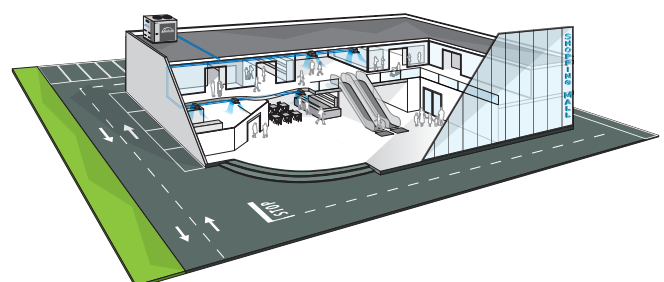

MPE heat pumps and water chillers are designed for heating or cooling the water to be used in air-conditioning systems for residential, commercial or industrial use.

MAIN COMPONENTS

Structure

Painted galvanised sheet steel structure (RAL9002) for an effective resistance to corrosive agents. Fastening devices are made of non-oxidizable carbon steel that has undergone surface-passivating treatments.

Customised hydraulic kit

The structure can accommodate hydronic kits with pump, expansion tank, and buffer tank. High head pump made entirely of stainless steel, already configured for use with mixtures of water and ethylene glycol up to 25% and provided with internal thermal protection.

Fan drive assembly

Electric fan with external rotor motor directly keyed to the axial fan, with internal thermal protection on the windings.

Finned block heat exchanger

Made of 8mm diameter copper pipes and aluminium fins. The heat exchangers' particular design makes it possible to speed up to the maximum the defrost phases in the versions with heat pump with obvious benefits to seasonal efficiency while operating in heating mode.

Electronic microprocessor control

The electronic controller enables the complete control of the MPE unit. It can be easily accessed through a polycarbonate flap with IP65 protection rating.

It implements the compressor regulation logic and allows the complete management of the unit's other parts, the reversal of the cooling cycle, and the alarms.



CONFIGURATOR

The models are completely configurable by selecting the version and the options. To the right is shown an example of configuration.

Version	Field	1	2	3	4	5	6	7	8	9	10	11	12	13
MPET18COAC		A	1	S	0	E	0	3	M	2	0	G	2	1

To verify the compatibility of the options, use the selection software or the price list.

AVAILABLE VERSIONS

Only cooling versions

MPE..COAC
MPE..CZAC

Power supply 400V-3N-50Hz
Power supply 400V-3N-50H + circuit breaker

Reversible heat pump versions

MPE..HOAA
MPE..HMAA
MPE..HZAA
MPE..H4AA

Power supply 400V-3N-50Hz
Power supply 230V-1N-50H
Power supply 400V-3N-50H + circuit breaker
Power supply 230V-1N-50H + circuit breaker

CONFIGURATION OPTIONS

- | | |
|---|--|
| <p>1 Expansion valve</p> <ul style="list-style-type: none"> 0 Mechanical A Electronic <p>2 Water pump and accessories</p> <ul style="list-style-type: none"> 0 Absent 1 LP pump + expansion vessel 2 LP run and standby double pump + expansion vessel (advanced controller required) <p>3 Water buffer tank</p> <ul style="list-style-type: none"> 0 Absent S Selected <p>4 Partial heat recovery</p> <ul style="list-style-type: none"> 0 Absent D Desuperheater with pump activation contact <p>5 Air flow modulation</p> <ul style="list-style-type: none"> C Condensation control by phase-cut fans E Condensation control performed by EC fans <p>6 Antifreezing kit</p> <ul style="list-style-type: none"> 0 Absent E Evaporator (tandem unit advanced controller required) P Evaporator and pump (tandem unit advanced controller required) S Evaporator, water pump and water buffer tank (tandem unit advanced controller required) <p>7 Acoustic insulation and attenuation</p> <ul style="list-style-type: none"> 0 Absent 1 Compressor compartment acoustic insulation 2 Compressor sound blanket 3 Compressor compartment acoustic insulation and sound blanket <p>8 Refrigerant pipework accessories</p> <ul style="list-style-type: none"> 0 Absent | <ul style="list-style-type: none"> M Refrigerant pressure gauges <p>9 Remote control / Serial communication</p> <ul style="list-style-type: none"> 0 Absent 2 RS485 serial board (Carel / Modbus protocol) B BACNET IP / PCOWEB serial board (advanced controller required) F BACNET MS/TP / PCONET board (advanced controller required) G BACNET IP / PCOWEB serial board + supervision software Gweb (advanced controller required) S Remote simplified user panel X Remote simplified user panel for advanced controller <p>10 Special coils / Protective treatments</p> <ul style="list-style-type: none"> 0 Standard B Pre-painted fins with epoxy painting C Cataphoresis I Hydrophilic R Copper-copper <p>11 Outdoor finned coil heat exchanger protection</p> <ul style="list-style-type: none"> 0 Absent G Outdoor finned coil heat exchanger protection grille <p>12 Compressors options</p> <ul style="list-style-type: none"> 0 Absent 1 Power factor capacitors 2 Soft starter 3 Power factor capacitors + soft starter 4 Crankcase compressor heater (CHILLER), outdoor coil trace heater (HP) <p>13 Onboard controller</p> <ul style="list-style-type: none"> 1 Basic 2 Advanced |
|---|--|

ACCESSORIES

1701546	Remote simplified user panel
RYKAMF	Spring anti vibration shock mounts
RYPAM	Rubber anti vibration shock mounts

RYRT40	Tank module connection kit
RYT40	Inertial tank module for under-base installation

Air chillers and heat pumps MPE

RATED TECHNICAL DATA MPE C

MPE C		T18	T23	T25	T30	T34	T42	T54
Power supply	V-ph-Hz	400 - 3N - 50						
Cooling capacity	(1)(E) kW	19,9	23,4	26,0	31,9	35,9	42,5	54,6
Total power input	(1)(E) kW	7,80	8,70	8,90	10,7	12,8	15,0	18,7
EER	(1)(E)	2,56	2,68	2,94	2,97	2,79	2,83	2,93
SEER	(2)(E)	4,10	4,10	4,10	4,10	4,11	4,10	4,10
Water flow	(1) l/h	3435	4041	4480	5489	6181	7320	9400
Water pressure drop	(1)(E) kPa	52	48	35	34	42	37	41
Available pressure head - LP pumps	(1) kPa	111	92	96	126	101	98	145
Maximum current absorption	A	32,0	39,0	40,0	44,0	48,0	44,0	55,0
Start up current	A	85	95	96	100	116	164	177
Startup current with soft starter	A	65	73	74	78	90	123	134
Compressors / circuits		2 / 1						
Expansion vessel volume	dm ³	5	5	5	8	8	8	8
Buffer tank volume	dm ³	50	50	50	125	125	125	125
Sound power level	(3)(E) dB(A)	72	73	73	73	73	74	81
Transport weight unit with pump and tank	kg	232	256	260	448	484	521	643
Operating weight unit with pump and full tank	kg	282	306	309	555	591	663	751

MPE C		T57	T64	T71
Power supply	V-ph-Hz	400 - 3N - 50		
Cooling capacity	(1)(E) kW	56,9	65,8	71,5
Total power input	(1)(E) kW	19,9	22,6	26,2
EER	(1)(E)	2,86	2,91	2,73
SEER	(2)(E)	4,11	4,10	4,12
Water flow	(1) l/h	9795	11335	12306
Water pressure drop	(1)(E) kPa	37	37	37
Available pressure head - LP pumps	(1) kPa	147	142	136
Maximum current absorption	A	58,0	64,0	70,0
Start up current	A	182	196	238
Startup current with soft starter	A	138	149	179
Compressors / circuits		2 / 1		
Expansion vessel volume	dm ³	8	8	8
Buffer tank volume	dm ³	125	125	125
Sound power level	(3)(E) dB(A)	81	81	81
Transport weight unit with pump and tank	kg	665	685	786
Operating weight unit with pump and full tank	kg	773	793	894

(1) Outdoor air temperature 35°C, water temperature 12°C / 7°C (EN14511:2022)

(2) η efficiency values for heating and cooling are respectively calculated by the following formulas: $[\eta = SCOP / 2,5 - F(1) - F(2)]$ e $[\eta = SEER / 2,5 - F(1) - F(2)]$. For further information, please refer to the technical document "ErP 2009/125/EC DIRECTIVE" in the catalogue introducing pages, or to the EN14825:2022 regulation.

(3) Sound power level measured according to ISO 9614

(E) EUROVENT certified data

RATED TECHNICAL DATA MPE H

MPE H			004M	005M	007M	008	008M	009	010	010M	
Power supply		V-ph-Hz	230 - 1 - 50	230 - 1 - 50	230 - 1 - 50	400 - 3N - 50	230 - 1 - 50	400 - 3N - 50	400 - 3N - 50	230 - 1 - 50	
Cooling capacity	(1)(E)	kW	4,00	5,00	6,70	8,30	8,10	9,20	9,10	9,00	
Total power input	(1)(E)	kW	1,30	1,70	2,20	3,10	3,40	3,00	3,30	3,30	
EER	(1)(E)		2,98	2,94	3,03	2,64	2,41	3,08	2,76	2,75	
SEER	(2)(E)		3,16	3,02	3,22	3,17	2,98	3,54	3,15	3,15	
Water flow	(1)	l/h	687	858	1151	1424	1401	1585	1568	1554	
Water pressure drop	(1)(E)	kPa	5	5	9	6	6	16	33	33	
Available pressure head - LP pumps	(1)	kPa	77	74	55	67	67	146	115	115	
Heating capacity	(3)(E)	kW	4,70	5,90	7,50	9,90	10,3	10,5	10,9	11,0	
Total power input	(3)(E)	kW	1,50	1,80	2,20	3,30	3,70	3,40	3,60	3,60	
COP	(3)(E)		3,23	3,18	3,46	2,97	2,81	3,12	3,02	3,04	
SCOP	(2)(E)		3,45	3,59	3,57	3,51	3,26	3,30	3,05	3,05	
Heating energy efficiency class	(4)(E)		A+								
Water flow	(3)	l/h	815	1017	1307	1717	1781	1823	1890	1896	
Water pressure drop	(3)(E)	kPa	5	5	11	8	8	21	46	46	
Available pressure head - LP pumps	(3)	kPa	76	73	54	65	64	143	107	107	
Maximum current absorption		A	9,00	11,0	11,0	9,00	17,6	8,00	12,0	24,0	
Start up current		A	38	44	44	49	88	43	49	98	
Startup current with soft starter		A	26	30	30	34	66	29	33	68	
Compressors / circuits			1 / 1								
Expansion vessel volume		dm ³	1	1	1	1	1	5	5	5	
Buffer tank volume		dm ³	20	20	20	20	20	30	30	30	
Sound power level	(5)(E)	dB(A)	66	66	68	67	82	69	69	69	
Transport weight unit with pump and tank		kg	114	118	123	127	120	211	211	211	
Operating weight unit with pump and full tank		kg	123	127	132	136	129	227	227	227	

MPE H			013	014	015	018	020	021	024		
Power supply		V-ph-Hz	400 - 3N - 50								
Cooling capacity	(1)(E)	kW	12,6	14,0	14,6	16,7	20,8	20,1	23,2		
Total power input	(1)(E)	kW	4,20	4,60	5,30	6,40	7,80	7,00	8,20		
EER	(1)(E)		2,98	3,01	2,78	2,61	2,66	2,88	2,83		
SEER	(2)(E)		3,45	3,25	3,39	3,17	3,14	3,38	3,32		
Water flow	(1)	l/h	2174	2409	2516	2886	3592	3459	4000		
Water pressure drop	(1)(E)	kPa	59	10	36	49	57	18	47		
Available pressure head - LP pumps	(1)	kPa	81	139	102	130	109	140	109		
Heating capacity	(3)(E)	kW	15,3	15,9	17,7	20,1	23,9	24,6	27,3		
Total power input	(3)(E)	kW	4,80	5,00	5,60	6,80	8,00	7,30	8,30		
COP	(3)(E)		3,19	3,17	3,16	2,94	2,99	3,39	3,28		
SCOP	(2)(E)		3,34	3,62	3,47	3,22	3,22	3,55	3,44		
Heating energy efficiency class	(4)(E)		A+								
Water flow	(3)	l/h	2642	2764	3060	3479	4139	4264	4720		
Water pressure drop	(3)(E)	kPa	86	12	52	70	75	27	63		
Available pressure head - LP pumps	(3)	kPa	69	138	95	116	93	135	106		
Maximum current absorption		A	15,0	11,0	18,0	22,0	24,0	24,0	26,0		
Start up current		A	64	67	67	76	105	158	159		
Startup current with soft starter		A	44	46	46	51	72	110	110		
Compressors / circuits			1 / 1								
Expansion vessel volume		dm ³	5	5	5	5	5	5	5		
Buffer tank volume		dm ³	30	50	30	50	50	50	50		
Sound power level	(5)(E)	dB(A)	69	71	69	71	71	74	72		
Transport weight unit with pump and tank		kg	216	219	219	265	281	281	297		
Operating weight unit with pump and full tank		kg	232	236	236	301	317	317	333		

(1) Outdoor air temperature 35°C, water temperature 12°C / 7°C (EN14511:2022)

(2) η efficiency values for heating and cooling are respectively calculated by the following formulas: $[\eta = SCOP / 2,5 - F(1) - F(2)]$ e $[\eta = SEER / 2,5 - F(1) - F(2)]$. For further information, please refer to the technical document "ErP 2009/125/EC DIRECTIVE" in the catalogue introducing pages, or to the EN14825:2022 regulation.

(3) Outdoor air temperature dry bulb 7°C / wet bulb 6°C, water temperature 40°C / 45°C (EN14511:2022)

(4) Seasonal energy efficiency class for LOW TEMPERATURE room heating under AVERAGE climatic conditions [EUROPEAN REGULATION No 811/2013. The energy efficiency class of this product is included in the range A++++ → D]

(5) Sound power level measured according to ISO 9614

(E) EUROVENT certified data

Air chillers and heat pumps MPE

RATED TECHNICAL DATA MPE H

MPE H			027	028	T30	032	T34	035	040
Power supply		V-ph-Hz	400 - 3N - 50						
Cooling capacity	(1)(E)	kW	26,0	27,4	29,4	30,8	33,3	34,1	38,8
Total power input	(1)(E)	kW	9,5	8,80	10,5	10,2	12,7	11,7	12,9
EER	(1)(E)		2,74	3,11	2,80	3,02	2,62	2,91	3,00
SEER	(2)(E)		3,32	3,71	3,85	3,58	3,78	3,58	3,66
Water flow	(1)	l/h	4469	4722	5062	5309	5736	5873	6686
Water pressure drop	(1)(E)	kPa	32	39	29	49	37	39	42
Available pressure head - LP pumps	(1)	kPa	118	139	146	120	130	126	115
Heating capacity	(3)(E)	kW	30,0	31,4	34,5	35,8	39,3	39,3	44,3
Total power input	(3)(E)	kW	9,00	9,30	11,1	10,7	13,0	11,8	13,4
COP	(3)(E)		3,32	3,37	3,12	3,34	3,03	3,34	3,31
SCOP	(2)(E)		3,57	3,60	3,66	3,64	3,70	3,70	3,64
Heating energy efficiency class	(4)(E)		A+						
Water flow	(3)	l/h	5189	5438	5975	6190	6801	6809	7675
Water pressure drop	(3)(E)	kPa	43	50	39	64	51	51	53
Available pressure head - LP pumps	(3)	kPa	115	134	137	113	117	118	111
Maximum current absorption		A	32,0	32,0	37,0	34,0	43,0	38,0	40,0
Start up current		A	133	134	86	166	96	162	164
Startup current with soft starter		A	91	91	64	114	71	111	112
Compressors / circuits			1 / 1	1 / 1	2 / 1	1 / 1	2 / 1	1 / 1	1 / 1
Expansion vessel volume		dm ³	5	8	8	8	8	8	8
Buffer tank volume		dm ³	50	125	125	125	125	125	125
Sound power level	(5)(E)	dB(A)	72	73	76	73	72	73	75
Transport weight unit with pump and tank		kg	313	427	448	456	484	487	516
Operating weight unit with pump and full tank		kg	350	534	555	563	591	595	624

MPE H			T42	054	T54	T61	066	T69	T76
Power supply		V-ph-Hz	400 - 3N - 50						
Cooling capacity	(1)(E)	kW	42,5	51,8	53,2	60,5	62,5	68,5	74,5
Total power input	(1)(E)	kW	15,2	18,1	18,6	21,7	24,5	24,0	28,0
EER	(1)(E)		2,79	2,86	2,86	2,79	2,55	2,85	2,66
SEER	(2)(E)		3,76	3,57	3,77	3,78	3,18	3,42	3,97
Water flow	(1)	l/h	7320	8938	9173	10425	10763	11800	12837
Water pressure drop	(1)(E)	kPa	37	56	51	64	53	50	58
Available pressure head - LP pumps	(1)	kPa	98	107	138	122	89	129	115
Heating capacity	(3)(E)	kW	48,0	61,2	60,3	67,8	75,5	76,6	85,2
Total power input	(3)(E)	kW	16,1	18,9	18,9	22,1	23,8	23,9	27,4
COP	(3)(E)		2,98	3,24	3,19	3,07	3,18	3,21	3,11
SCOP	(2)(E)		3,68	3,58	3,55	3,47	3,48	3,67	3,56
Heating energy efficiency class	(4)(E)		A+						
Water flow	(3)	l/h	8308	10578	10440	11736	13063	13266	14740
Water pressure drop	(3)(E)	kPa	47	82	58	74	81	56	69
Available pressure head - LP pumps	(3)	kPa	84	90	137	116	66	124	105
Maximum current absorption		A	44,0	46,0	48,0	53,0	41,0	57,0	69,0
Start up current		A	164	163	177	187	165	202	229
Startup current with soft starter		A	123	110	130	138	112	149	169
Compressors / circuits			2 / 1	1 / 1	2 / 1	2 / 1	1 / 1	2 / 1	2 / 1
Expansion vessel volume		dm ³	8	8	8	8	8	8	8
Buffer tank volume		dm ³	125	125	125	125	125	125	125
Sound power level	(5)(E)	dB(A)	74	78	81	81	78	81	81
Transport weight unit with pump and tank		kg	521	521	643	665	558	685	786
Operating weight unit with pump and full tank		kg	629	630	751	773	665	793	894

(1) Outdoor air temperature 35°C, water temperature 12°C / 7°C (EN14511:2022)

(2) η efficiency values for heating and cooling are respectively calculated by the following formulas: $[\eta = SCOP / 2,5 - F(1) - F(2)]$ e $[\eta = SEER / 2,5 - F(1) - F(2)]$. For further information, please refer to the technical document "ErP 2009/125/EC DIRECTIVE" in the catalogue introducing pages, or to the EN14825:2022 regulation.

(3) Outdoor air temperature dry bulb 7°C / wet bulb 6°C, water temperature 40°C / 45°C (EN14511:2022)

(4) Seasonal energy efficiency class for LOW TEMPERATURE room heating under AVERAGE climatic conditions [EUROPEAN REGULATION No 811/2013. The energy efficiency class of this product is included in the range A+++ → D]

(5) Sound power level measured according to ISO 9614

(E) EUROVENT certified data

DIMENSIONAL DRAWINGS

MPE 4 - 8

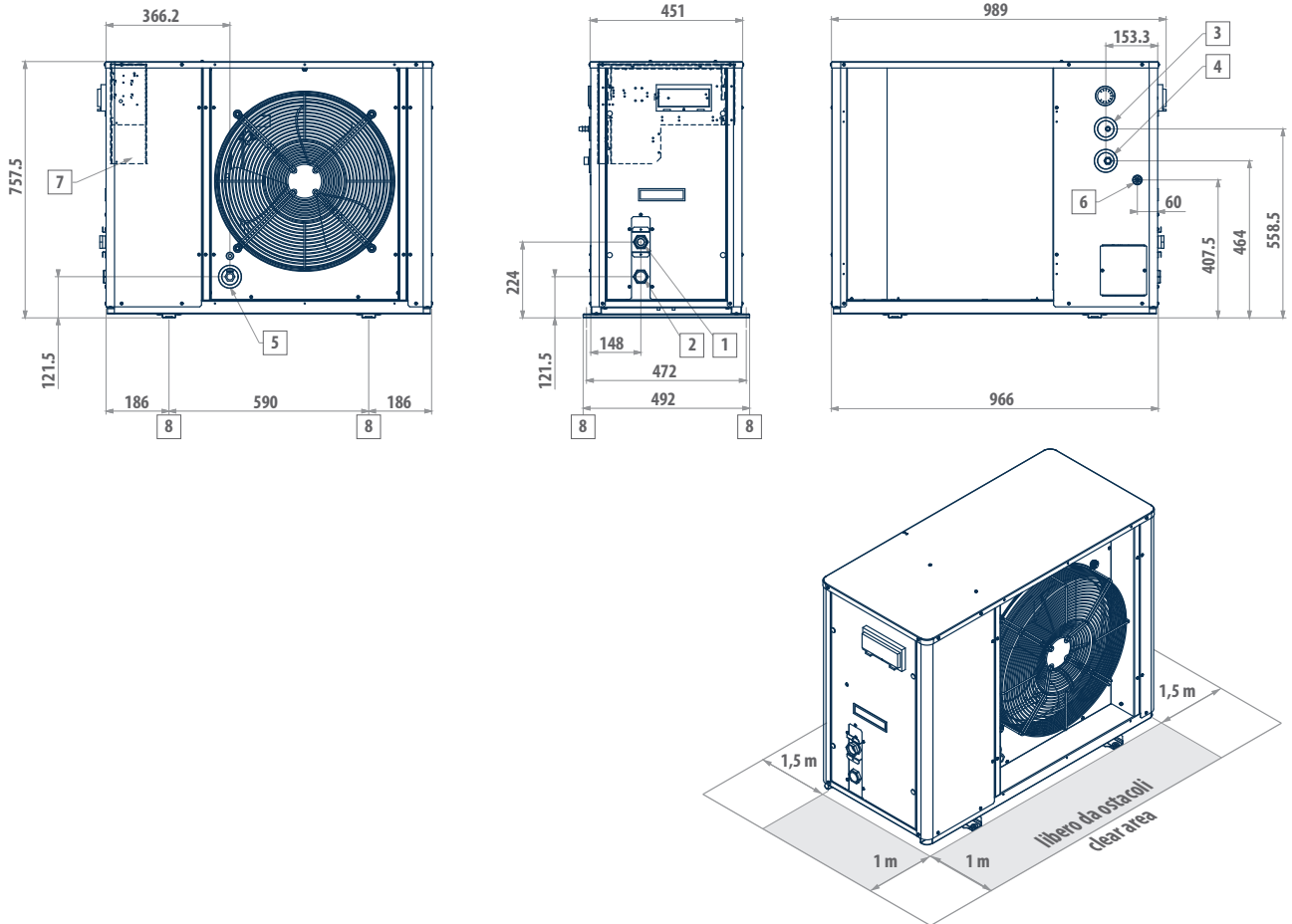

LEGEND

1	Water inlet 1" female
2	Water outlet 1" female
3	Safety valve discharge outlet provided with rubber ring holder
4	Water supply 1/2" male (optional tap)
5	Water drainage 1/2" female
6	Power supply \varnothing 28 mm
7	Electric control board
8	Fastening points for vibration dampers (accessory)

DIMENSIONAL DRAWINGS

MPE 9 - 15

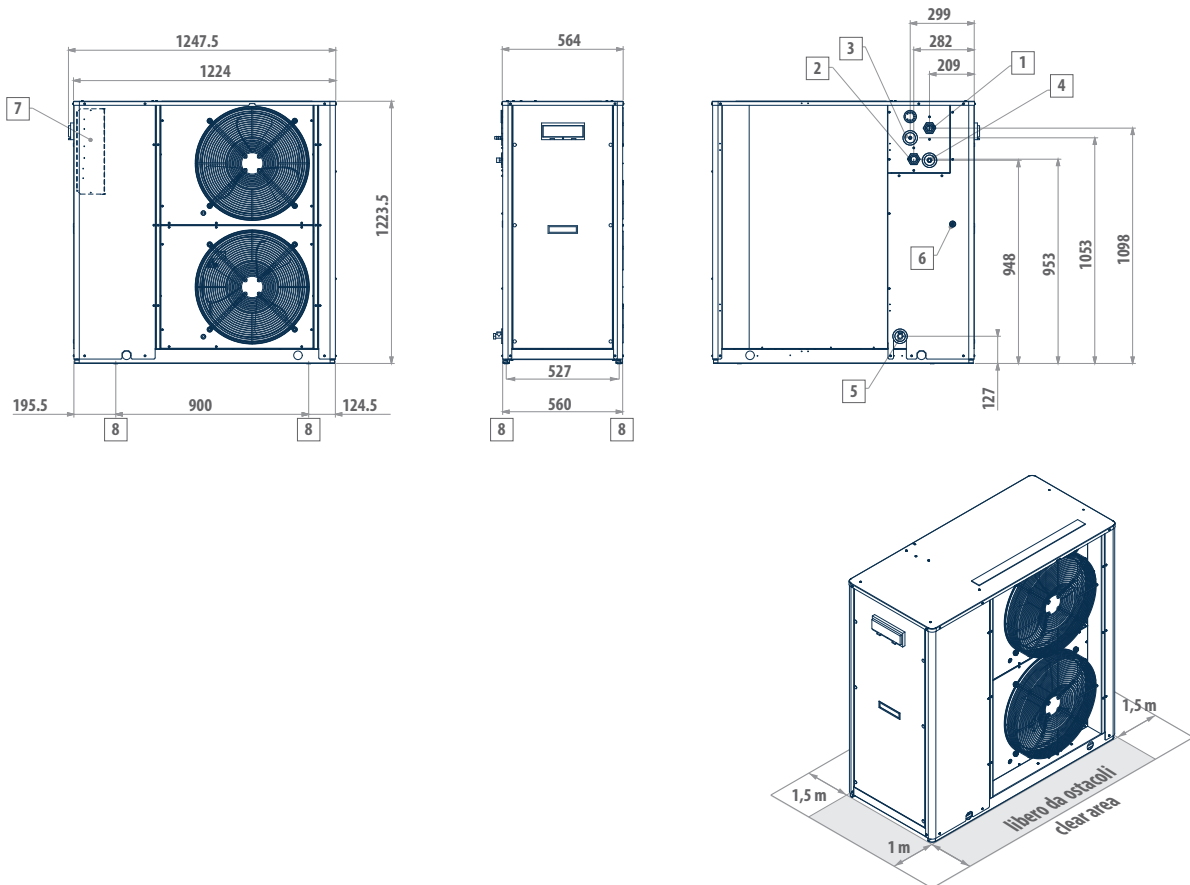

LEGEND

1	Water inlet 1" 1/4 female
2	Water outlet 1" 1/4 female
3	Safety valve discharge outlet provided with rubber ring holder
4	Water supply 1/2" male (optional tap)
5	Water drainage 1/2" female
6	Power supply \varnothing 28 mm
7	Electric control board
8	Vibration dumpers

DIMENSIONAL DRAWINGS

MPE 14 H + MPE 18 - 27

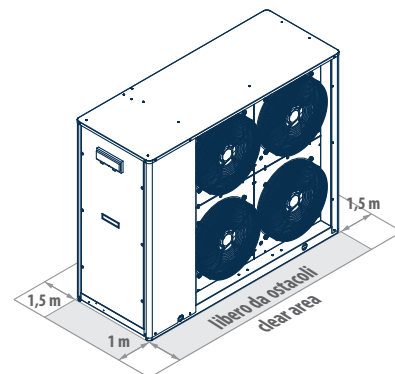
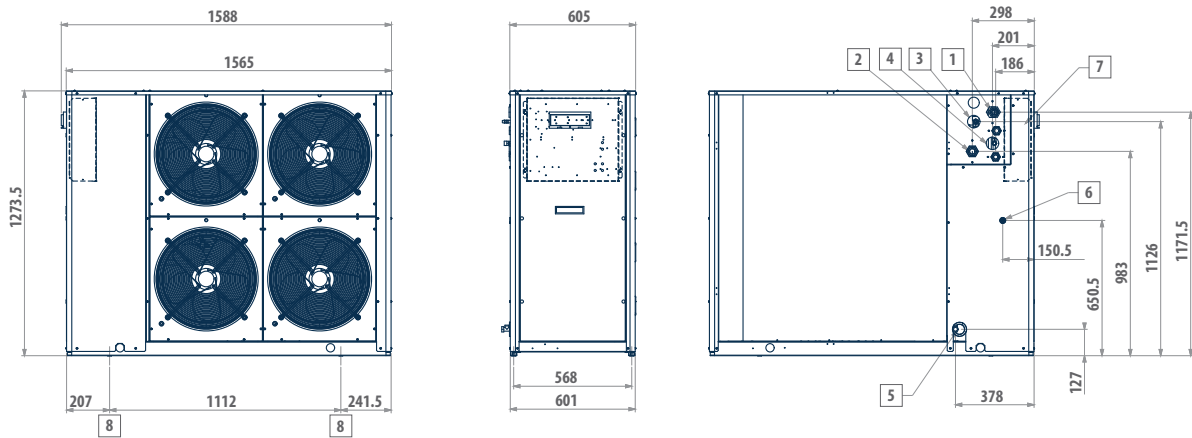

LEGEND

1	Water inlet 1" 1/4 female
2	Water outlet 1" 1/4 female
3	Safety valve discharge outlet provided with rubber ring holder
4	Water supply 1/2" male (optional tap)
5	Water drainage 1/2" female
6	Power supply \varnothing 28 mm
7	Electric control board
8	Vibration dumpers

DIMENSIONAL DRAWINGS

MPE T18 - T23 - T25

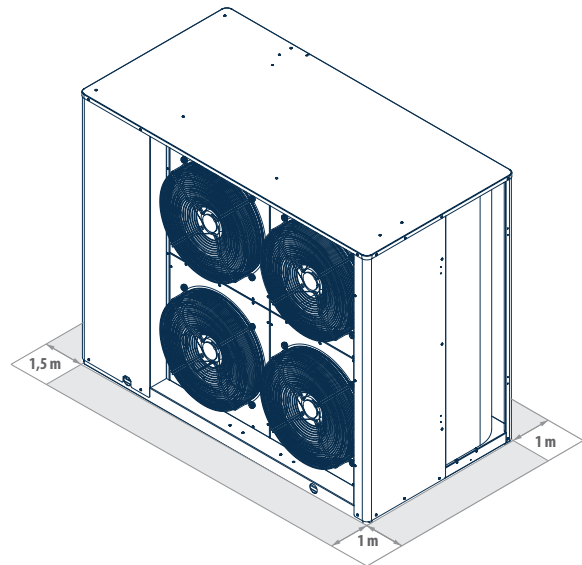
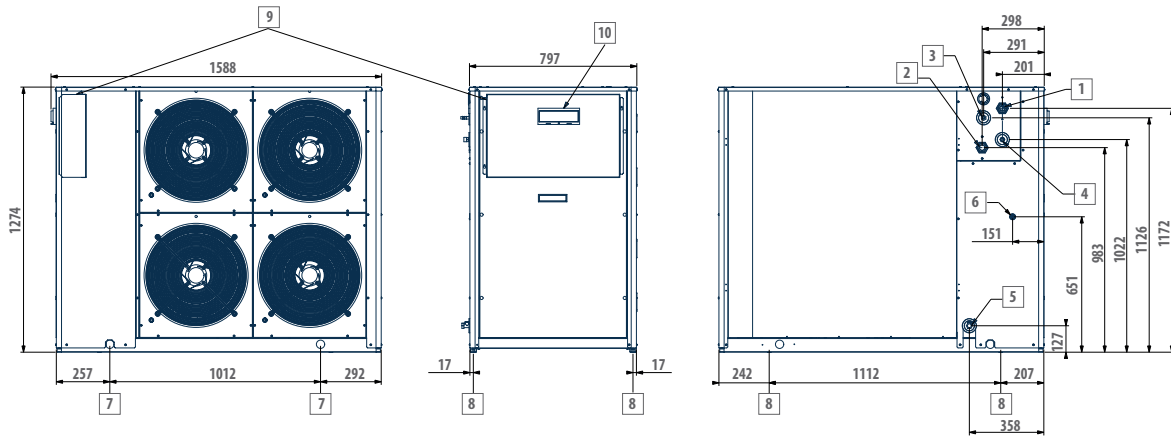

LEGEND

1	Water inlet 1" 1/4 female
2	Water outlet 1" 1/4 female
3	Safety valve discharge outlet provided with rubber ring holder
4	Water supply 1/2" male (optional tap)
5	Water drainage 1/2" female
6	Power supply \varnothing 28 mm
7	Lifting points
8	Vibration dumpers
9	Electric control board
10	User interface

DIMENSIONAL DRAWINGS

MPE 28 - 40 - MPE T30 - T42

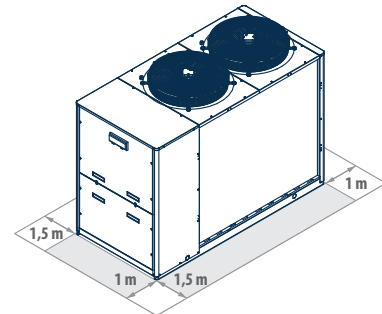
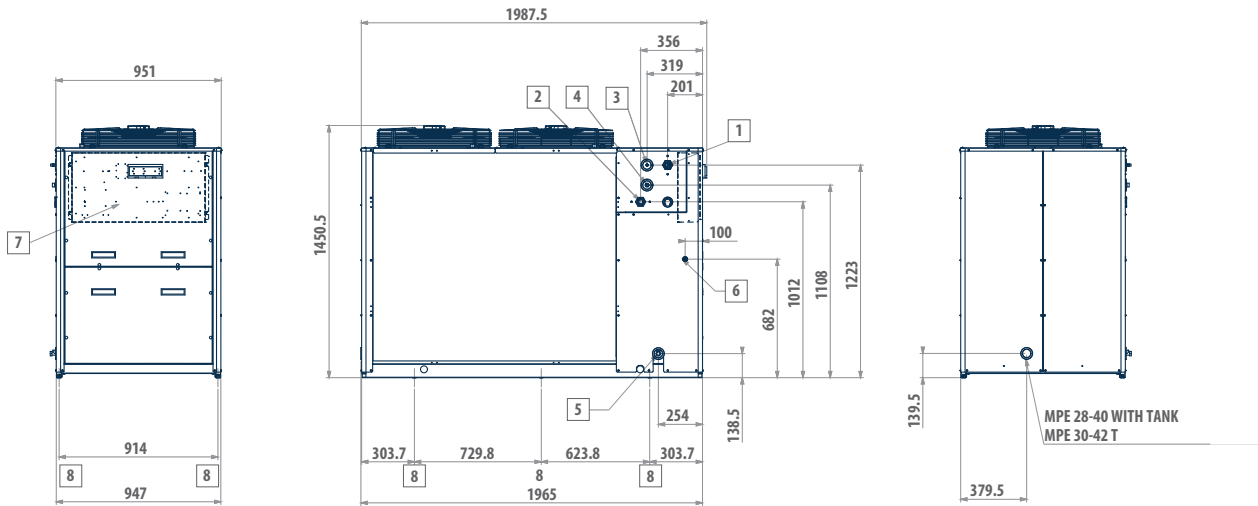

LEGEND

1	Water inlet 1" 1/4 female
2	Water outlet 1" 1/4 female
3	Safety valve discharge outlet provided with rubber ring holder
4	Water supply 1/2" male (optional tap)
5	Water drainage 1/2" female
6	Power supply ø 37 mm
7	Electric control board
8	Vibration dumpers

DIMENSIONAL DRAWINGS

MPE 54 ÷ 66

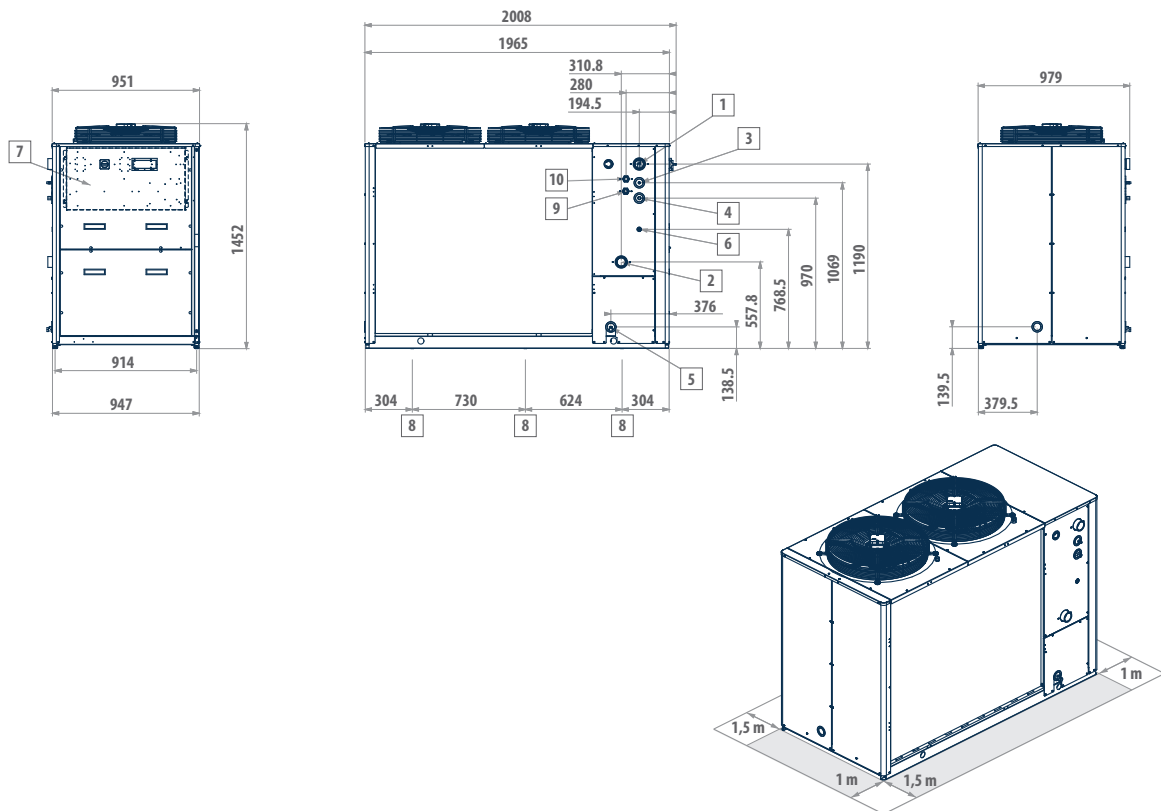

LEGEND

1	Water inlet 2" female
2	Water outlet 2" female
3	Safety valve discharge outlet provided with rubber ring holder
4	Water supply 1/2" male
5	Water drainage 1/2" female
6	Power supply
7	Electric control board
8	Fastening points for vibration dampers (accessory)

DIMENSIONAL DRAWINGS

MPE T54 ÷ T76

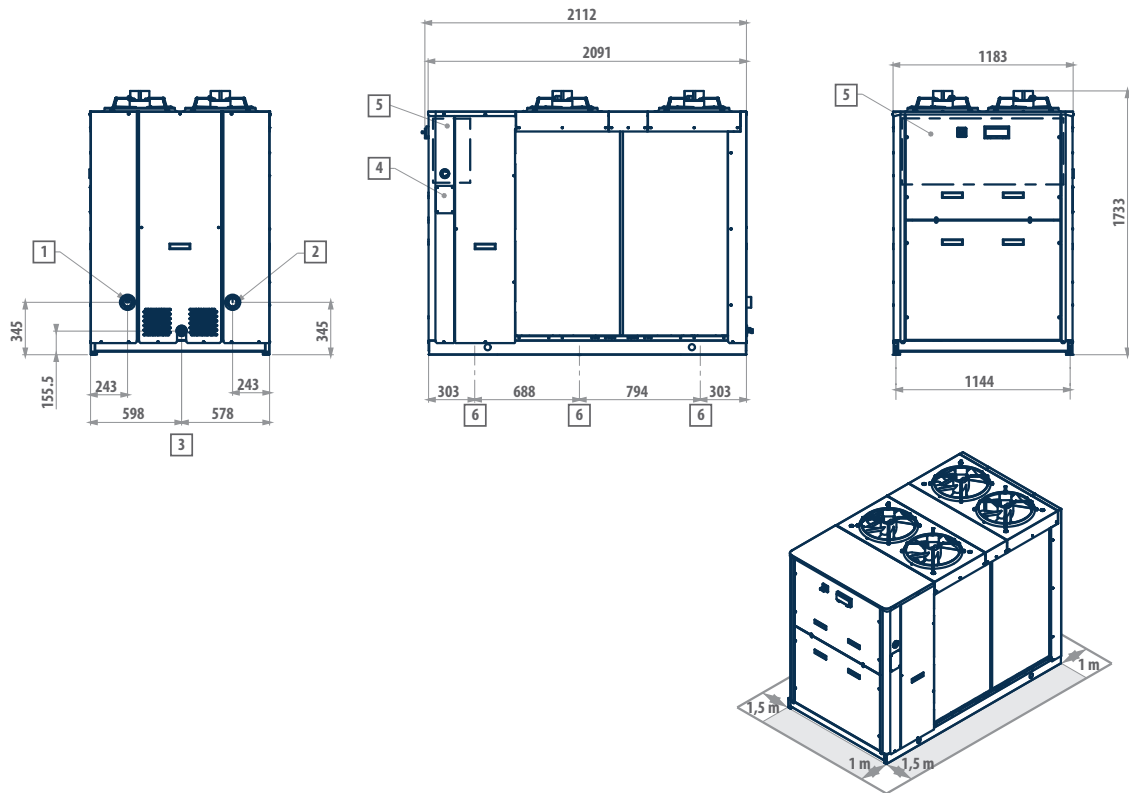

LEGEND

1	Water inlet 2" female
2	Water outlet 2" female
3	Water drainage 1/2" female
4	Power supply
5	Electric control board
6	Fastening points for vibration dampers

High-efficiency full inverter compact outdoor packaged units

MLI 5 - 30 kW

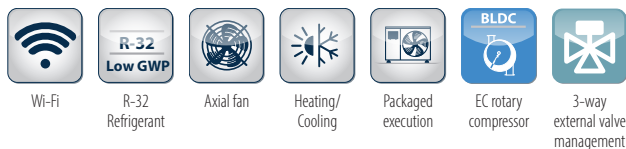
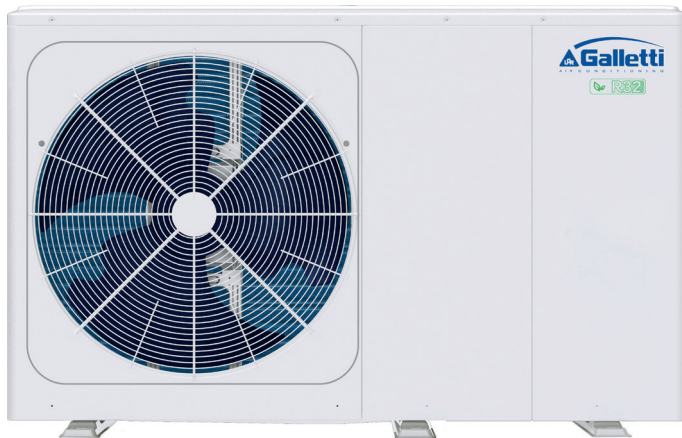

PLUS

- » Twin-rotary compressor driven by an electric EC motor
- » EC hydraulic pump
- » EC axial fan
- » Advanced system management and adjustment strategies
- » Access to tax deductions

High efficiency full inverter heat pumps

MLI is a range of heat pumps consisting of 9 unit sizes and 10 models, equipped with a state-of-the-art inverter compressor capable of efficiently meeting the cooling or thermal power requirements of residential or light commercial buildings.

All models, that access to tax deductions prouded for by actual law, takes full advantage of some of the most innovative HVAC technologies: in fact, all the units are full-inverter and the extended use of electrical motors with permanent magnets driven by inverters with direct current, even for the accessory components – such as fans and water circulators – drastically reduces electrical power consumption and minimizes it under every operating condition, ensuring an energy efficiency level that puts them solidly in class A++ or A+++.

Thanks to the advanced management strategies that have been implemented, the control electronics integrate the functioning of the units' key components, thereby optimizing interaction between the main parts: compressor, fan, and water circulator.

INERTIAL TANK MODULE OPTION

For all sizes, an optional module with an inertial tank is available for installation under the base. The kit includes the storage tank with a capacity of 50 liters when combined with units from 6 to 16 kW, or 140 liters when combined with units from 18 to 30 kW, and the components for hydraulic and mechanical connection. The tank can be used as an in-line storage by closing 2 of the 4 available hydraulic connections with the supplied plugs.

MAIN COMPONENTS



Control unit

The user terminal of the MLI series heat pumps is not a simple remote control, but a sophisticated controller that is capable of extending the basic functions implemented in the unit's electronics. It allows you not only to manage with absolute ease the basic daily functions the machine is intended to provide (on and off, setting the operating mode, instant activation of predefined comfort settings), but also to access advanced programming levels. Customized time slots according to real usage needs and the ability to implement climatic curves on the basis of which to modulate the operation of the unit in order to maximize the overall efficiency of the heating and air-conditioning system, in addition to the ability to manage external equipment such as dehumidifiers, additional hydraulic circulators for primary/secondary loop systems, 3-way valves for the production of domestic hot water and boilers or external backup devices, are just some of the advantages offered to users by this powerful interface. The clear and ergonomic display of the main parameters and the ability to provide in-depth diagnoses of operation are a valuable aid for the maintenance and service operations, it is also possible to remotely control the main functions via smartphone, through the dedicated app.

Heat exchanger

Brazed-welded plate condenser in AISI 316 corrosion resistant austenitic stainless steel, specifically developed to maximise heat exchange coefficients between water and refrigerant.



Fan

The sound levels are especially low thanks to the use of a specially designed fan with airfoil blades that is able to ensure a high air flow rate with limited noise emission.

Compressor

Hermetic twin-rotary compressor driven by a permanent magnet BLDC motor and equipped with a double acoustic insulation is fixed to the base by means of vibration-damping supports.

EXTENDED OPERATING RANGE FOR EACH APPLICATION

MLI series heat pumps were designed to ensure maximum flexibility in every application. Thanks to their extremely wide operating range ensuring the operation even in particularly cold climates and allowing them to produce water up to a maximum of 65 °C and to the advanced adjustment logics provided by the electronic control, they are able to ensure not only winter heating and summer air conditioning, but also the production of thermal energy to be used for domestic hot water production. The high efficiency values that characterize them make it possible, in many cases, to cover the share of renewable energy required by the most recent regulations on limiting energy consumption and to benefit from the tax credits offered by the legislation of many countries that are dedicated to promoting equipment that meets the highest standards.

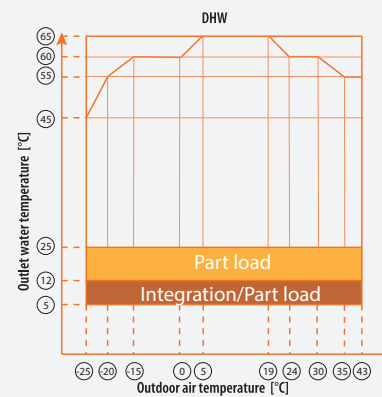
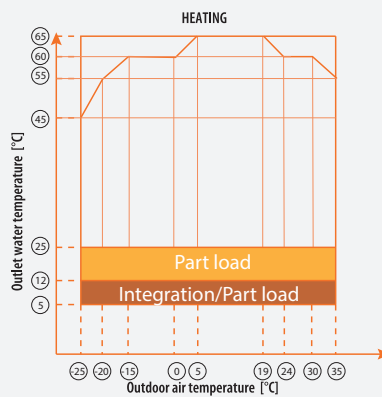
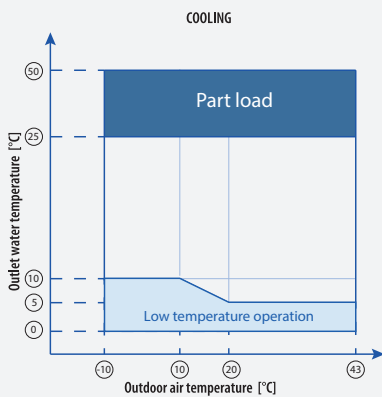

The cooling operating range refers to the dual-fan versions from MLI 018 to MLI 030. For the cooling operating range of the other versions, please refer to the technical manual.

PERFORMANCE AND FUNCTIONALITY ALWAYS ON TOP

The control unit is able to activate an alternative heat generator (boiler or heating element) and employ its operation according to various user-configurable logics in unfavorable weather conditions and particularly high thermal loads, in order to integrate the missing heat capacity or to completely replace heat generation. This feature can also be used during the defrost phases, in order to balance the energy extracted from the heat transfer fluid to melt the ice present on the outside of the heat exchanger, or in the case of machine stoppage due to malfunction or maintenance.

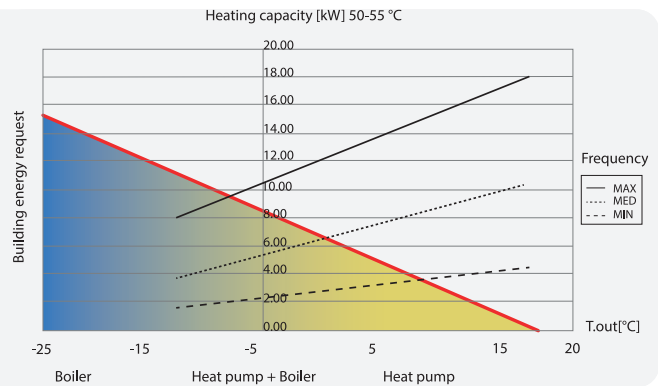

All the models of the MLI range feature extremely compact size and low weight, which allow them to be installed even in environments with high population density and particularly small installation spaces. This is contributed to also by the multi-speed inverter circulator and the expansion tank integrated in the internal hydronic module, thus making superfluous the use of a dedicated technical compartment and in this manner simplifying and speeding up the installation operations. The units' structural metalwork was designed to facilitate maintenance operations and allow easy access to the main internal parts even in the case of limited clearance.

Air Chiller and PDC with low GWP chiller MLI

RATED TECHNICAL DATA

MLI			006M	008M	010M	012M	016	016M
Power supply		V-ph-Hz	230-1-50	230-1-50	230-1-50	230-1-50	400-3N-50	230-1-50
Cooling capacity	(1)(E)	kW	7,00	7,45	8,20	11,5	14,0	14,0
Total power input	(1)(E)	kW	2,33	2,22	2,52	4,18	5,60	5,60
EER	(1)(E)		3,00	3,35	3,25	2,75	2,50	2,50
SEER	(2)(E)		5,34	5,83	5,98	4,89	4,67	4,69
η_{sc}	(2)(E)		209	229	234	194	183	184
Water flow	(1)	l/h	1204	1281	1410	1978	2408	2408
Available pressure head - LP pumps	(1)(E)	kPa	83	82	80	64	49	49
Heating capacity	(3)(E)	kW	6,30	8,10	10,0	12,3	16,0	16,0
Total power input	(3)(E)	kW	1,70	2,10	2,67	3,32	4,57	4,57
COP	(3)(E)		3,70	3,85	3,75	3,70	3,50	3,50
SCOP	(2)(E)		4,95	5,21	5,19	4,81	4,62	4,62
η_{sh}	(2)(E)		195	205	204	189	181	181
Heating energy efficiency class	(4)					A+++		
SCOP	(2)(E)		3,52	3,36	3,49	3,45	3,41	3,41
η_{sh}	(2)(E)		137	131	136	135	133	133
Heating energy efficiency class	(5)					A++		
Water flow	(3)	l/h	1084	1393	1720	2116	2752	2752
Available pressure head - LP pumps	(3)(E)	kPa	85	80	70	64	49	49
Cooling capacity	(6)(E)	kW	6,50	8,30	9,90	12,0	14,2	14,2
Total power input	(6)(E)	kW	1,35	1,64	2,18	3,04	3,93	3,93
EER	(6)(E)		4,80	5,05	4,55	3,95	3,61	3,61
Heating capacity	(7)(E)	kW	6,35	8,40	10,0	12,1	15,9	15,9
Total power input	(7)(E)	kW	1,28	1,63	2,02	2,44	3,53	3,53
COP	(7)(E)		4,95	5,15	4,95	4,95	4,50	4,50
Maximum current absorption		A	18,0	19,0	19,0	30,0	14,0	30,0
Compressors / circuits						1/1		
Expansion vessel volume		dm ³	8	8	8	8	8	8
Sound power level	(8)(E)	dB(A)	58	59	60	65	68	68
Operating weight - unit with pump		kg	126	153	153	175	193	175

(1) Outdoor air temperature 35°C, water temperature 12°C / 7°C (EN14511:2022)

(2) η efficiency values for heating and cooling are respectively calculated by the following formulas: $[\eta = SCOP / 2,5 - F(1) - F(2)]$ e $[\eta = SEER / 2,5 - F(1) - F(2)]$. For further information, please refer to the technical document "ErP 2009/125/EC DIRECTIVE" in the catalogue introducing pages, or to the EN14825:2022 regulation.

(3) Outdoor air temperature dry bulb 7°C / wet bulb 6°C, water temperature 40°C / 45°C (EN14511:2022)

(4) Seasonal energy efficiency class for LOW TEMPERATURE room heating under AVERAGE climatic conditions [EUROPEAN REGULATION No 811/2013. The energy efficiency class of this product is included in the range A+++ → D]

(5) Seasonal energy efficiency class for MEDIUM TEMPERATURE room heating under AVERAGE climatic conditions [EUROPEAN REGULATION No 811/2013. The energy efficiency class of this product is included in the range A+++ → D]

(6) Outdoor air temperature 35°C, water temperature 23°C / 18°C (EN14511:2022)

(7) Outdoor air temperature dry bulb 7°C / wet bulb 6°C, water temperature 30°C / 35°C (EN14511:2022)

(8) Sound power level measured according to ISO 9614

(E) EUROVENT certified data

RATED TECHNICAL DATA

MLI			018	022	026	030
Power supply		V-ph-Hz	400-3N-50			
Cooling capacity	(1)(E)	kW	17,0	21,0	26,0	29,5
Total power input	(1)(E)	kW	5,57	7,12	9,63	11,6
EER	(1)(E)		3,05	2,95	2,70	2,55
SEER	(2)(E)		4,49	4,66	4,70	4,70
η_{sc}	(2)(E)		177	183	185	185
Water flow	(1)	l/h	2924	3612	4472	5074
Available pressure head - LP pumps	(1)(E)	kPa	102	95	78	61
Heating capacity	(3)(E)	kW	18,0	22,0	26,0	30,0
Total power input	(3)(E)	kW	5,14	6,47	8,39	10,3
COP	(3)(E)		3,50	3,40	3,10	2,90
SCOP	(2)(E)		4,60	4,53	4,50	4,19
η_{sh}	(2)(E)		181	178	177	165
Heating energy efficiency class	(4)		A+++	A+++	A+++	A++
SCOP	(2)(E)		3,21	3,22	3,14	3,14
η_{sh}	(2)(E)		125	126	123	123
Heating energy efficiency class	(5)		A++	A++	A+	A+
Water flow	(3)	l/h	3096	3784	4472	5159
Available pressure head - LP pumps	(3)(E)	kPa	100	91	77	58
Cooling capacity	(6)(E)	kW	18,5	23,0	27,0	31,0
Total power input	(6)(E)	kW	3,89	5,00	6,28	7,75
EER	(6)(E)		4,75	4,60	4,30	4,00
Heating capacity	(7)(E)	kW	18,0	22,0	26,0	30,1
Total power input	(7)(E)	kW	3,83	5,00	6,37	7,70
COP	(7)(E)		4,70	4,40	4,08	3,91
Maximum current absorption		A	18,0	21,0	24,0	28,0
Compressors / circuits			1/1			
Expansion vessel volume		dm ³	8	8	8	8
Sound power level	(8)(E)	dB(A)	71	73	75	77
Operating weight - unit with pump		kg	206	206	206	206

(1) Outdoor air temperature 35°C, water temperature 12°C / 7°C (EN14511:2022)

(2) η efficiency values for heating and cooling are respectively calculated by the following formulas: [$\eta = SCOP / 2,5 - F(1) - F(2)$] e [$\eta = SEER / 2,5 - F(1) - F(2)$]. For further information, please refer to the technical document "ErP 2009/125/EC DIRECTIVE" in the catalogue introducing pages, or to the EN14825:2022 regulation.

(3) Outdoor air temperature dry bulb 7°C / wet bulb 6°C, water temperature 40°C / 45°C (EN14511:2022)

(4) Seasonal energy efficiency class for LOW TEMPERATURE room heating under AVERAGE climatic conditions [EUROPEAN REGULATION No 811/2013. The energy efficiency class of this product is included in the range A+++ → D]

(5) Seasonal energy efficiency class for MEDIUM TEMPERATURE room heating under AVERAGE climatic conditions [EUROPEAN REGULATION No 811/2013. The energy efficiency class of this product is included in the range A+++ → D]

(6) Outdoor air temperature 35°C, water temperature 23°C / 18°C (EN14511:2022)

(7) Outdoor air temperature dry bulb 7°C / wet bulb 6°C, water temperature 30°C / 35°C (EN14511:2022)

(8) Sound power level measured according to ISO 9614

(E) EUROVENT certified data

Air Chiller and PDC with low GWP chiller MLI

DIMENSIONAL DRAWINGS

MLI 006

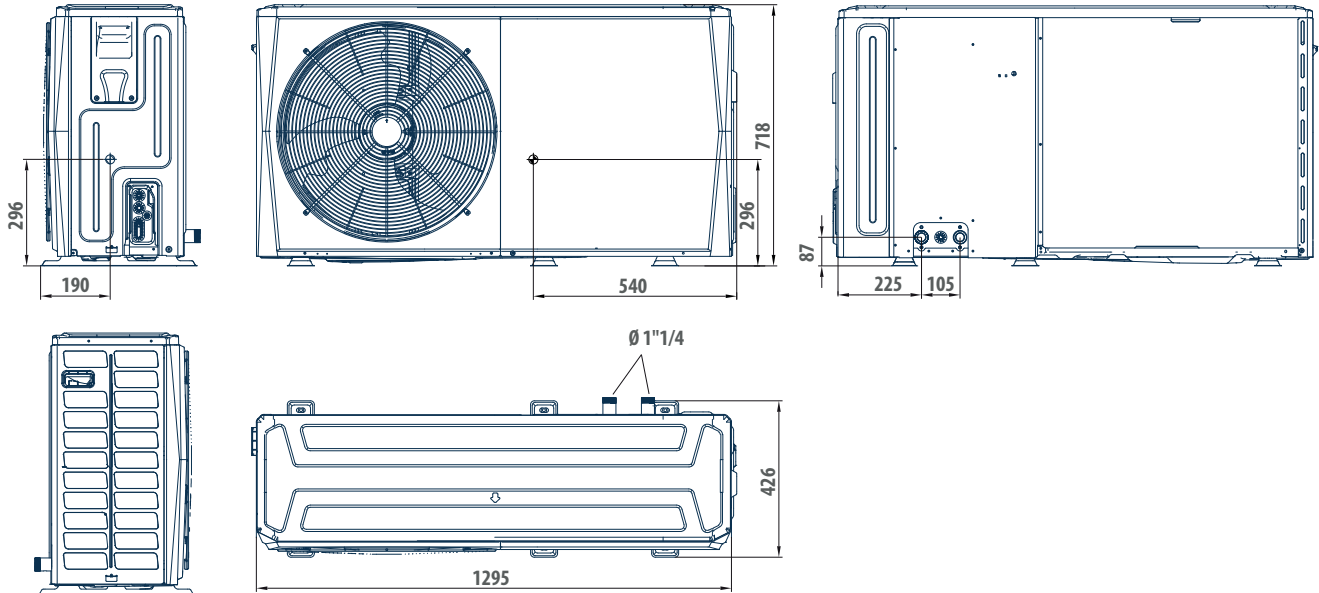

MLI 008-010-012-016

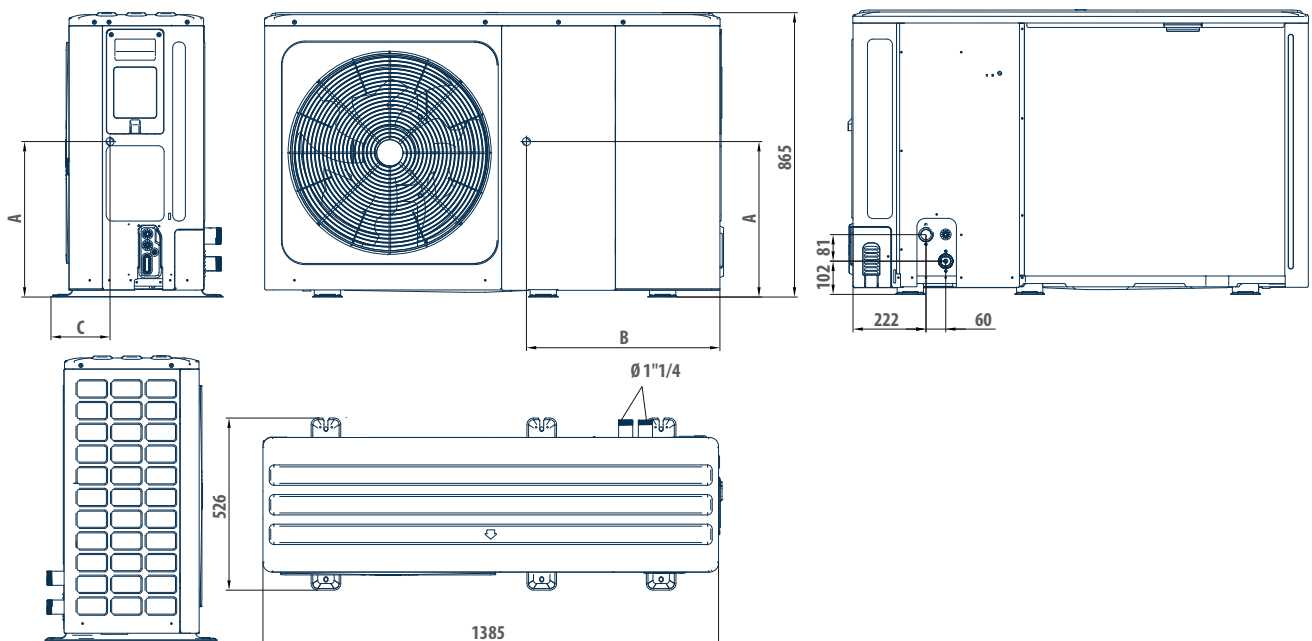

MLI	A mm	B mm	C mm
008M - 010M	330	580	280
012M - 016M	290	605	245
016	200	605	245

DIMENSIONAL DRAWINGS

MLI 018-022-026-030

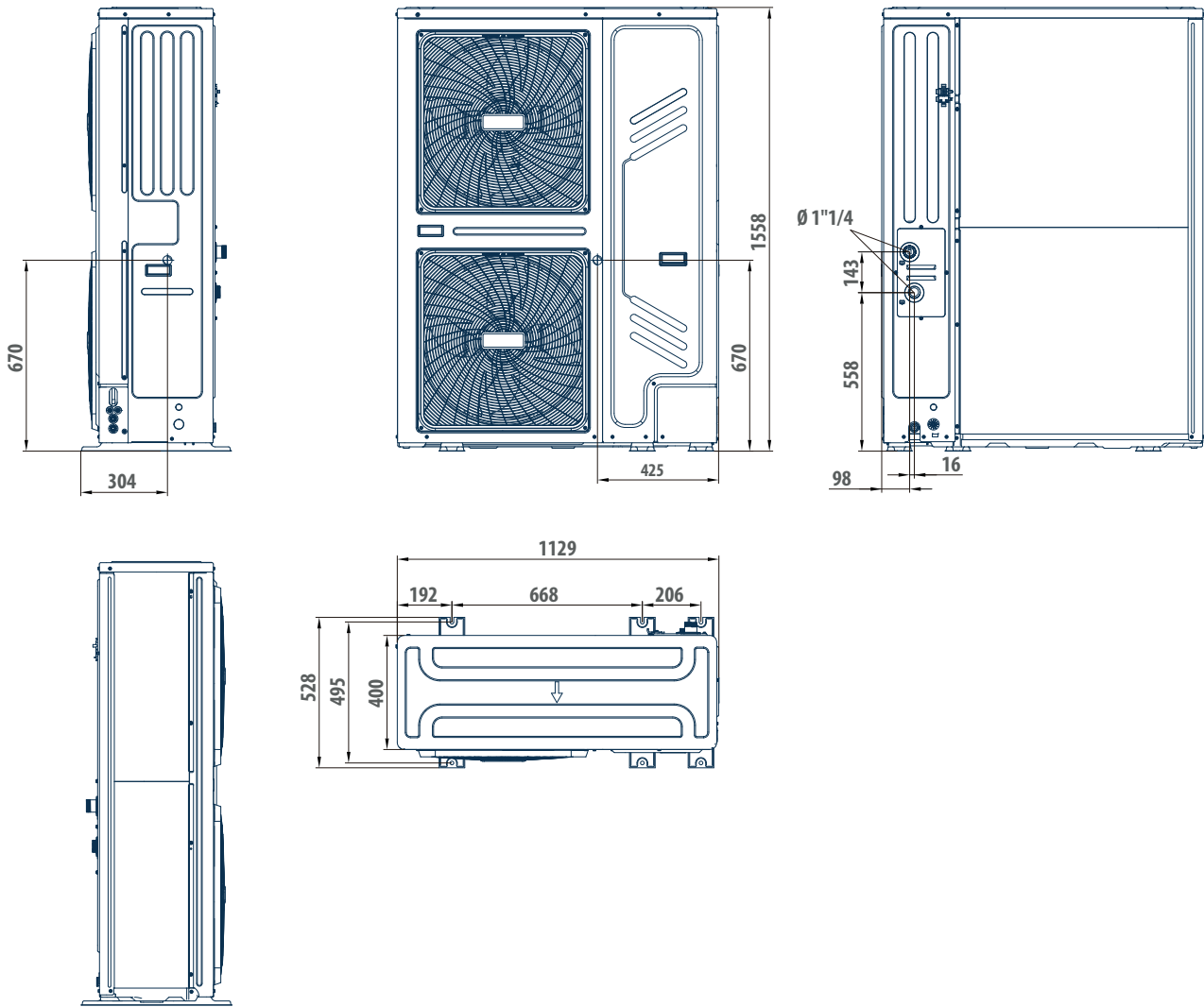

Split units with EC compressor

DLI 06 - 16 kW



High efficiency full inverter heat pumps

DLI is a range of heat pumps consisting of 5 unit sizes and 7 models, equipped with a state-of-the-art inverter compressor capable of efficiently meeting the cooling or thermal power requirements of residential or light commercial buildings.

All models, that access to tax deductions prouded for by actual law, takes full advantage of some of the most innovative HVAC technologies: in fact, all the units are full-inverter and the extended use of electrical motors with permanent magnets driven by inverters with direct current, even for the accessory components – such as fans and water circulators – drastically reduces electrical power consumption and minimizes it under every operating condition, ensuring an energy efficiency level that puts them solidly in class A++ or A+++. Thanks to the advanced management strategies that have been implemented, the control electronics integrate the functioning of the units' key components, thereby optimizing interaction between the main parts: compressor, fan, and water circulator.

The DLI system always consists of: an outdoor unit (OLI identification code) which is combined with an indoor unit (ILI identification code).

Double option for indoor unit

It is possible to choose between two different options: ILI*M wall-mounted indoor unit with reduced dimensions and connections arranged in the lower part to simplify the installation phase, and ILI*S all-in-one floor-standing indoor unit with 240 l tank, resistance electric power of 3 kW and built-in three-way valve for the direct production of domestic hot water.

PLUS

- » Twin-rotary compressor driven by an electric EC motor
- » EC hydraulic pump
- » EC axial fan
- » Advanced system management and adjustment strategies
- » Access to tax deductions

MAIN COMPONENTS



Control unit

The user terminal of the DLI series heat pumps is not a simple remote control, but a sophisticated controller that is capable of extending the basic functions implemented in the unit's electronics. It allows you not only to manage with absolute ease the basic daily functions the machine is intended to provide (on and off, setting the operating mode, instant activation of predefined comfort settings), but also to access advanced programming levels. Customized time slots according to real usage needs and the ability to implement climatic curves on the basis of which to modulate the operation of the unit in order to maximize the overall efficiency of the heating and air-conditioning system, in addition to the ability to manage external equipment such as dehumidifiers, additional hydraulic circulators for primary/secondary loop systems, 3-way valves for the production of domestic hot water and boilers or external backup devices, are just some of the advantages offered to users by this powerful interface. The clear and ergonomic display of the main parameters and the ability to provide in-depth diagnoses of operation are a valuable aid for the maintenance and service operations, it is also possible to remotely control the main functions via smartphone, through the dedicated app.

COMBINATIONS

OLI	006M	
ILI	010S	006M
OLI	008M	
ILI	010S	010M
OLI	010M	
ILI	010S	010M
OLI	012 / 012M	
ILI	016S	016M
OLI	016 / 016M	
ILI	016S	016M

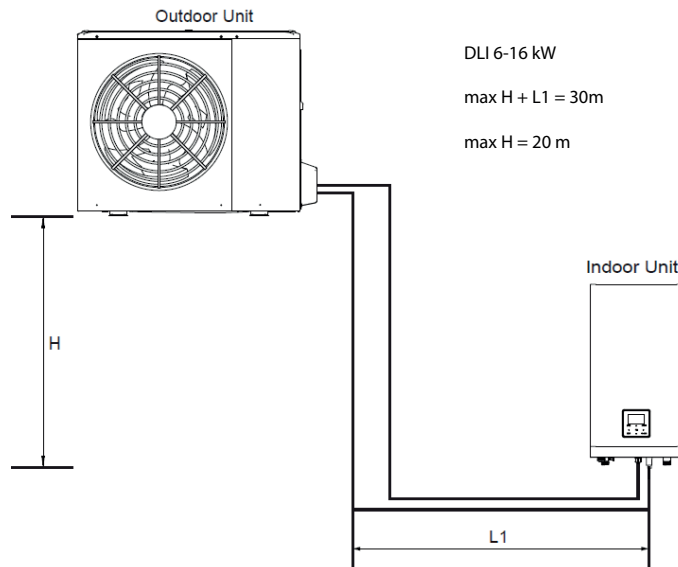

DLI 6-16 kW
 max H + L1 = 30m
 max H = 20 m

The maximum total length of the pipes for the connection between the outdoor unit and the indoor unit is 30 meters. The maximum difference in height allowed between the two units is instead 20 metres.

EXTENDED OPERATING RANGE FOR EACH APPLICATION

DLI series heat pumps were designed to ensure maximum flexibility in every application. Thanks to their extremely wide operating range ensuring the operation even in particularly cold climates and allowing them to produce water up to a maximum of 65 °C and to the advanced adjustment logics provided by the electronic control, they are able to ensure not only winter heating and summer air conditioning, but also the production of thermal energy to be used for domestic hot water production. The high efficiency values that characterize them make it possible, in many cases, to cover the share of renewable energy required by the most recent regulations on limiting energy consumption and to benefit from the tax credits offered by the legislation of many countries that are dedicated to promoting equipment that meets the highest standards.

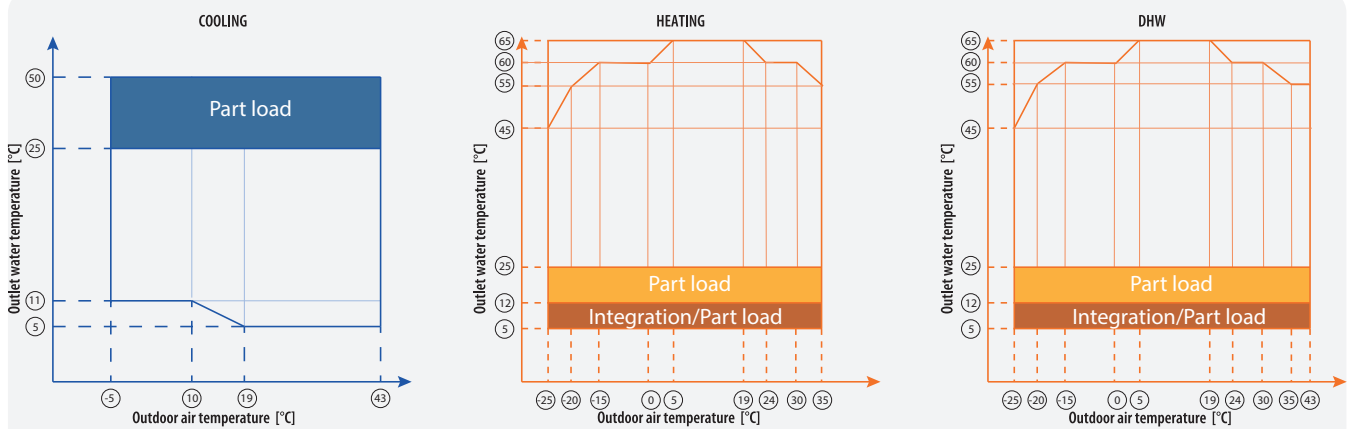

PERFORMANCE AND FUNCTIONALITY ALWAYS ON TOP

The control unit is able to activate an alternative heat generator (boiler or heating element) and employ its operation according to various user-configurable logics in unfavorable weather conditions and particularly high thermal loads, in order to integrate the missing heat capacity or to completely replace heat generation. This feature can also be used during the defrost phases, in order to balance the energy extracted from the heat transfer fluid to melt the ice present on the outside of the heat exchanger, or in the case of machine stoppage due to malfunction or maintenance.

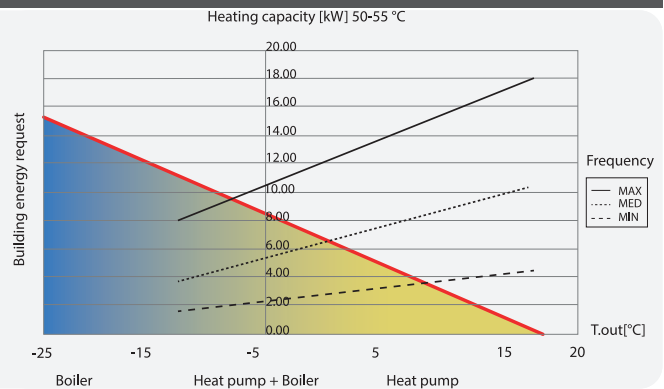

All the models of the DLI range feature extremely compact size and low weight, which allow them to be installed even in environments with high population density and particularly small installation spaces. The units' structural metalwork was designed to facilitate maintenance operations and allow easy access to the main internal parts even in the case of limited clearance.

Air Chiller and PDC with low GWP chiller - DLI

Air Chiller and PDC with low GWP chiller DLI

RATED TECHNICAL DATA OUTDOOR UNIT OLI

DLI			006M	008M	010M	012
Power supply		V-ph-Hz	230-1-50	230-1-50	230-1-50	400-3N-50
Cooling capacity	(1)(E)	kW	7,00	7,40	8,20	11,6
Total power input	(1)(E)	kW	2,33	2,19	2,48	4,22
EER	(1)(E)		3,00	3,38	3,31	2,75
SEER	(2)(E)		5,34	5,83	5,98	4,87
η_{sc}	(2)(E)		209	229	234	195
Water flow	(1)	l/h	1204	1273	1410	1995
Available pressure head - LP pumps	(1)(E)	kPa	83	82	80	64
Heating capacity	(3)(E)	kW	6,35	8,20	10,0	12,3
Total power input	(3)(E)	kW	1,69	2,08	2,63	3,24
COP	(3)(E)		3,76	3,94	3,80	3,80
SCOP	(4)(E)		4,95	5,21	5,19	4,81
η_{sh}	(4)(E)		195	206	205	189
Heating energy efficiency class	(5)		A+++			
SCOP	(6)(E)		3,52	3,36	3,49	3,45
η_{sh}	(6)(E)		138	132	137	135
Heating energy efficiency class	(7)		A++			
Water flow	(3)	l/h	1092	1410	1720	2116
Available pressure head - LP pumps	(3)(E)	kPa	85	80	70	65
Cooling capacity	(8)(E)	kW	6,55	8,40	10,0	12,0
Total power input	(8)(E)	kW	1,34	1,66	2,08	3,00
EER	(8)(E)		4,89	5,06	4,81	4,00
Heating capacity	(9)(E)	kW	6,20	8,30	10,0	12,1
Total power input	(9)(E)	kW	1,24	1,60	2,00	2,44
COP	(9)(E)		5,00	5,19	5,00	4,96
Maximum current absorption		A	18	19	19	14
Compressors / circuits			1/1			
Expansion vessel volume		dm ³	8	8	8	8
Sound power level	(10)(E)	dB(A)	58	59	60	68
Refrigerant charge	(11)	kg	1,50	1,65	1,65	1,84
Weight		kg	63,5	89	89	112

(1) Outdoor air temperature 35°C, water temperature 12°C / 7°C (EN14511:2022)

(2) η efficiency values for heating and cooling are respectively calculated by the following formulas: $[\eta = SCOP / 2,5 - F(1) - F(2)]$ e $[\eta = SEER / 2,5 - F(1) - F(2)]$. For further information, please refer to the technical document "ErP 2009/125/EC DIRECTIVE" in the catalogue introducing pages, or to the EN14825:2022 regulation.

(3) Outdoor air temperature dry bulb 7°C / wet bulb 6°C, water temperature 40°C / 45°C (EN14511:2022)

(4) η efficiency values for heating and cooling are respectively calculated by the following formulas: $[\eta = SCOP / 2,5 - F(1) - F(2)]$ e $[\eta = SEER / 2,5 - F(1) - F(2)]$. For further information, please refer to the technical document "ErP 2009/125/EC DIRECTIVE" in the catalogue introducing pages, or to the EN14825:2022 regulation. Low temperature conditions.

(5) Seasonal energy efficiency class for LOW TEMPERATURE room heating under AVERAGE climatic conditions [EUROPEAN REGULATION No 811/2013. The energy efficiency class of this product is included in the range A+++ → D]

(6) η efficiency values for heating and cooling are respectively calculated by the following formulas: $[\eta = SCOP / 2,5 - F(1) - F(2)]$ e $[\eta = SEER / 2,5 - F(1) - F(2)]$. For further information, please refer to the technical document "ErP 2009/125/EC DIRECTIVE" in the catalogue introducing pages, or to the EN14825:2022 regulation. Medium temperature conditions.

(7) Seasonal energy efficiency class for MEDIUM TEMPERATURE room heating under AVERAGE climatic conditions [EUROPEAN REGULATION No 811/2013. The energy efficiency class of this product is included in the range A+++ → D]

(8) Outdoor air temperature 35°C, water temperature 23°C / 18°C (EN14511:2022)

(9) Outdoor air temperature dry bulb 7°C / wet bulb 6°C, water temperature 30°C / 35°C (EN14511:2022)

(10) Sound power level measured according to ISO 9614

(11) Kg gas value is estimated. For the exact value refer to the plate data on the unit.

(E) EUROVENT certified data

RATED TECHNICAL DATA OUTDOOR UNIT OLI

DLI			012M	016	016M
Power supply		V-ph-Hz	230-1-50	400-3N-50	230-1-50
Cooling capacity	(1)(E)	kW	11,6	14,0	14,0
Total power input	(1)(E)	kW	4,22	5,71	5,71
EER	(1)(E)		2,75	2,45	2,45
SEER	(2)(E)		4,89	4,67	4,69
η_{sc}	(2)(E)		194	184	183
Water flow	(1)	l/h	1995	2408	2408
Available pressure head - LP pumps	(1)(E)	kPa	64	49	49
Heating capacity	(3)(E)	kW	12,3	16,0	16,0
Total power input	(3)(E)	kW	3,24	4,44	4,44
COP	(3)(E)		3,80	3,60	3,60
SCOP	(4)(E)		4,81	4,62	4,62
η_{sh}	(4)(E)		189	182	182
Heating energy efficiency class	(5)			A+++	
SCOP	(6)(E)		3,45	3,41	3,41
η_{sh}	(6)(E)		135	133	133
Heating energy efficiency class	(7)			A++	
Water flow	(3)	l/h	2116	2752	2752
Available pressure head - LP pumps	(3)(E)	kPa	64	49	49
Cooling capacity	(8)(E)	kW	12,0	14,9	14,9
Total power input	(8)(E)	kW	3,00	4,38	4,38
EER	(8)(E)		4,00	3,40	3,40
Heating capacity	(9)(E)	kW	12,1	16,0	16,0
Total power input	(9)(E)	kW	2,44	3,56	3,56
COP	(9)(E)		4,96	4,49	4,49
Maximum current absorption		A	30	14	30
Compressors / circuits				1/1	
Expansion vessel volume		dm ³	8	8	8
Sound power level	(10)(E)	dB(A)	64	68	64
Refrigerant charge	(11)	kg	1,84	1,84	1,84
Weight		kg	97	112	97

(1) Outdoor air temperature 35°C, water temperature 12°C / 7°C (EN14511:2022)

(2) η efficiency values for heating and cooling are respectively calculated by the following formulas: $[\eta = SCOP / 2,5 - F(1) - F(2)]$ e $[\eta = SEER / 2,5 - F(1) - F(2)]$. For further information, please refer to the technical document "ErP 2009/125/EC DIRECTIVE" in the catalogue introducing pages, or to the EN14825:2022 regulation.

(3) Outdoor air temperature dry bulb 7°C / wet bulb 6°C, water temperature 40°C / 45°C (EN14511:2022)

(4) η efficiency values for heating and cooling are respectively calculated by the following formulas: $[\eta = SCOP / 2,5 - F(1) - F(2)]$ e $[\eta = SEER / 2,5 - F(1) - F(2)]$. For further information, please refer to the technical document "ErP 2009/125/EC DIRECTIVE" in the catalogue introducing pages, or to the EN14825:2022 regulation. Low temperature conditions.

(5) Seasonal energy efficiency class for LOW TEMPERATURE room heating under AVERAGE climatic conditions [EUROPEAN REGULATION No 811/2013. The energy efficiency class of this product is included in the range A+++ → D]

(6) η efficiency values for heating and cooling are respectively calculated by the following formulas: $[\eta = SCOP / 2,5 - F(1) - F(2)]$ e $[\eta = SEER / 2,5 - F(1) - F(2)]$. For further information, please refer to the technical document "ErP 2009/125/EC DIRECTIVE" in the catalogue introducing pages, or to the EN14825:2022 regulation. Medium temperature conditions.

(7) Seasonal energy efficiency class for MEDIUM TEMPERATURE room heating under AVERAGE climatic conditions [EUROPEAN REGULATION No 811/2013. The energy efficiency class of this product is included in the range A+++ → D]

(8) Outdoor air temperature 35°C, water temperature 23°C / 18°C (EN14511:2022)

(9) Outdoor air temperature dry bulb 7°C / wet bulb 6°C, water temperature 30°C / 35°C (EN14511:2022)

(10) Sound power level measured according to ISO 9614

(11) Kg gas value is estimated. For the exact value refer to the plate data on the unit.

(E) EUROVENT certified data

Air Chiller and PDC with low GWP chiller DLI

DIMENSIONAL DRAWINGS

DLI 006

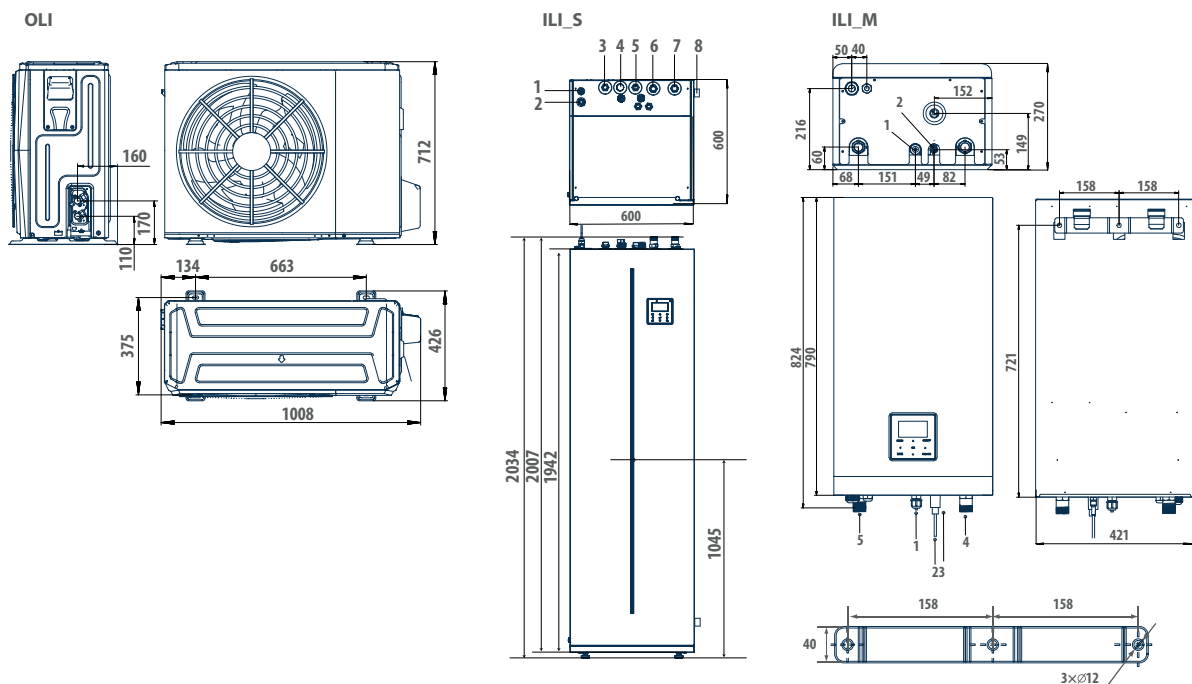

LEGENDA ILI M

- | | |
|---|---|
| 1 | Connection gas refrigerant 5/8" - 18 UNF |
| 2 | Connection liquid refrigerant 1/4" - 28 UNF |
| 3 | Condensate discharge Ø 25 mm |
| 4 | Water inlet R1" |
| 5 | Water outlet R1" |

LEGENDA ILI S

- | | |
|---|---|
| 1 | Connection gas refrigerant 5/8" - 18 UNF |
| 2 | Connection liquid refrigerant 3/8" - 24 UNF |
| 3 | Domestic hot water outlet R3/4" |
| 4 | Domestic hot water recirculation inlet (connection with dice) |
| 5 | Domestic hot water inlet R3/4" |
| 6 | Hot / cold system water inlet R1" |
| 7 | Hot / cold system water outlet R1" |
| 8 | Condensate discharge Ø 25 mm |

	OLI		006M
	ILI	010S	006M
OLI - Weight	kg		63,5
ILI - Weight	kg	170	43
OLI - Sound pressure level Lw	db(A)		58
ILI - Sound power level	db(A)	38	38

DIMENSIONAL DRAWINGS

DLI 008-016

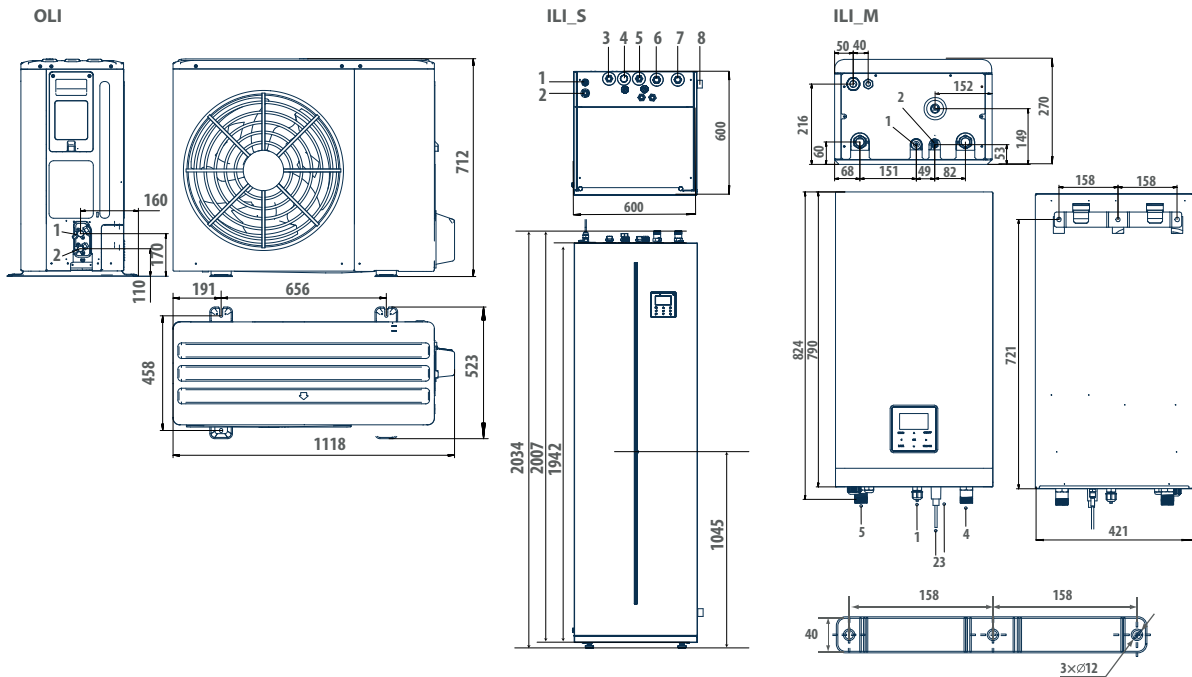

LEGENDA ILI M

1	Connection gas refrigerant 5/8" - 18 UNF
2	Connection liquid refrigerant 3/8" - 24 UNF
3	Condensate discharge Ø 25 mm
4	Water inlet R1"
5	Water outlet R1"

LEGENDA ILI S

1	Connection gas refrigerant 5/8" - 18 UNF
2	Connection liquid refrigerant 3/8" - 24 UNF
3	Domestic hot water outlet R3/4"
4	Domestic hot water recirculation inlet (connection with dice)
5	Domestic hot water inlet R3/4"
6	Hot / cold system water inlet R1"
7	Hot / cold system water outlet R1"
8	Condensate discharge Ø 25 mm

OLI	008M	
ILI	010S	010M
OLI	010M	
ILI	010S	010M
OLI	012 / 012M	
ILI	016S	016M
OLI	016 / 016M	
ILI	016S	016M

	OLI	008M		010M		012M		012		016M		016	
	ILI	010S	010M	010S	010M	016S	016M	016S	016M	016S	016M	016S	016M
OLI - Weight	kg	89		89		97		112		97		112	
ILI - Weight	kg	170	43	170	43	172	45	172	45	172	45	172	45
OLI - Sound pressure level Lw	db(A)	59		60		64		68		64		68	
ILI - Sound power level	db(A)	40	42	40	42	42	43	42	43	44	43	44	43

High-efficiency full inverter compact outdoor packaged units



MLP 06 - 30 kW

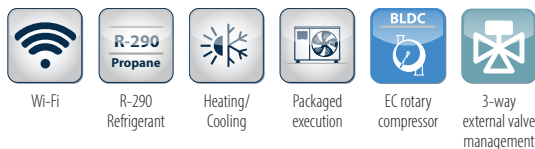

PLUS

- » Twin-rotary compressor driven by an electric EC motor
- » EC hydraulic pump
- » EC axial fan
- » Advanced system management and adjustment strategies
- » Access to tax deductions
- » Very Low GWP natural refrigerant
- » Production of hot water up to 75°C

High efficiency full inverter heat pumps

MLP is a range of heat pumps consisting of 7 unit sizes and 9 models, equipped with a latest generation inverter compressor capable of satisfying the requests for cooling, heating and DHW production power in buildings in the most efficient way residential or light commercial. Thanks to the use of R290, MLP heat pumps guarantee high performance with wide working ranges. The high seasonal efficiencies and the very low GWP make it the ideal product for achieving thermo-hygrometric well-being while fully respecting the environment.

All models, that access to tax deductions prouded for by actual law, takes full advantage of some of the most innovative HVAC technologies: in fact, all the units are full-inverter and the extended use of electrical motors with permanent magnets driven by inverters with direct current, even for the accessory components – such as fans and water circulators – drastically reduces electrical power consumption and minimizes it under every operating condition, ensuring an energy efficiency level. The hermetically sealed electrical panel also guarantees greater reliability and safety. Thanks to the advanced management strategies that have been implemented, the control electronics integrate the functioning of the units' key components, thereby optimizing interaction between the main parts: compressor, fan, and water circulator.

R290 (propane) is a natural refrigerant. Its very low GWP value, equal to 3, makes it the optimal solution to help reduce the environmental impact of greenhouse gases and therefore global warming. Furthermore, due to its technical characteristics, it allows the working range of heat pumps to be expanded, allowing their use even in extreme and very harsh conditions, guaranteeing the production of high temperature water. We manage to guarantee an outlet water temperature of 50°C even with external temperatures of -25°C, reaching a maximum of 75°C starting from -10°C. Due to its flammability (class A3), particular attention must be paid to the characteristics of the installation site. The regulatory legislation EN 378 part 3 specifies the requirements to be respected for the safe management of the installation site.

MAIN COMPONENTS



New controller with color screen, touch key design and intuitive interface that improves customer experience. The heat pump user terminal MLP is a sophisticated controller capable of extending the basic functions of the electronics on board the machine. In addition to managing the main functions, it also allows access to advanced programming levels.

Customized time slots and the possibility of implementing climate curves allow to modulate the operation of the machine and maximize the overall efficiency of the heating and air conditioning system. It allows the management of external equipment such as dehumidifiers, additional hydraulic circulators, three-way valves for the production of domestic hot water and boilers or other external backup devices. Easy to install thanks to a non-polarized wiring connection.

EXTENDED OPERATING RANGE FOR EACH APPLICATION

MLP series heat pumps were designed to ensure maximum flexibility in every application. Thanks to their extremely wide operating range ensuring the operation even in particularly cold climates and allowing them to produce water up to a maximum of 75°C and to the advanced adjustment logics provided by the electronic control, they are able to ensure not only winter heating and summer air conditioning, but also the production of thermal energy to be used for domestic hot water production. Thanks to the use of propane, MLP is able to guarantee hot water at 55°C with an external temperature of -25°C, up to a maximum of 75°C with a minimum external temperature of -10°C

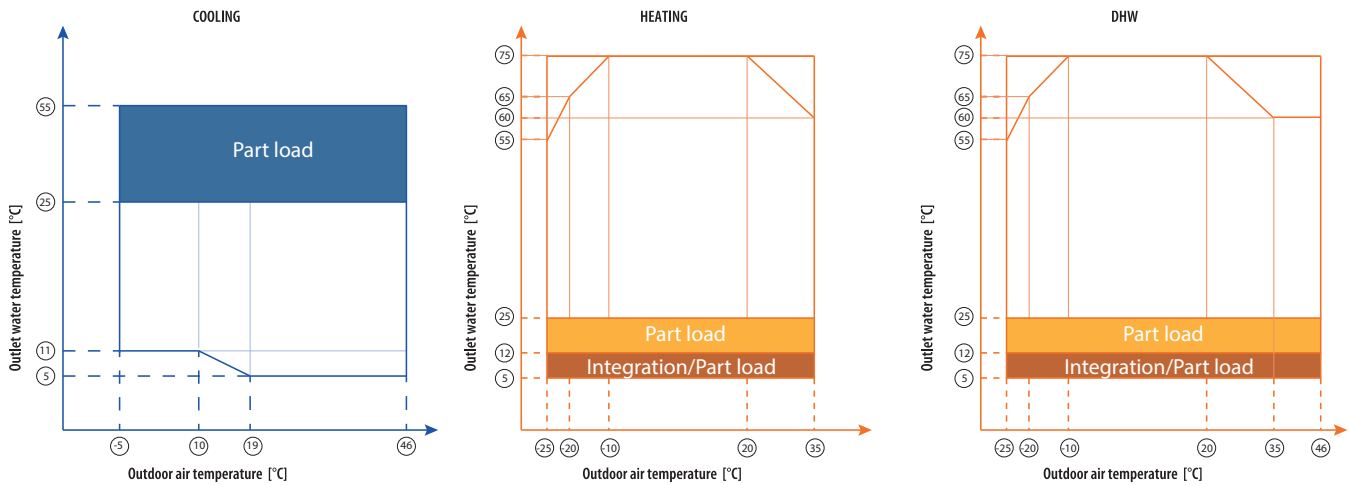

INSTALLATION EXAMPLE

With MLP it is possible to connect up to 6 machines in cascade, and manage up to two different zones. At the same time it is possible to manage an external three-way valve for the management of domestic hot water production.

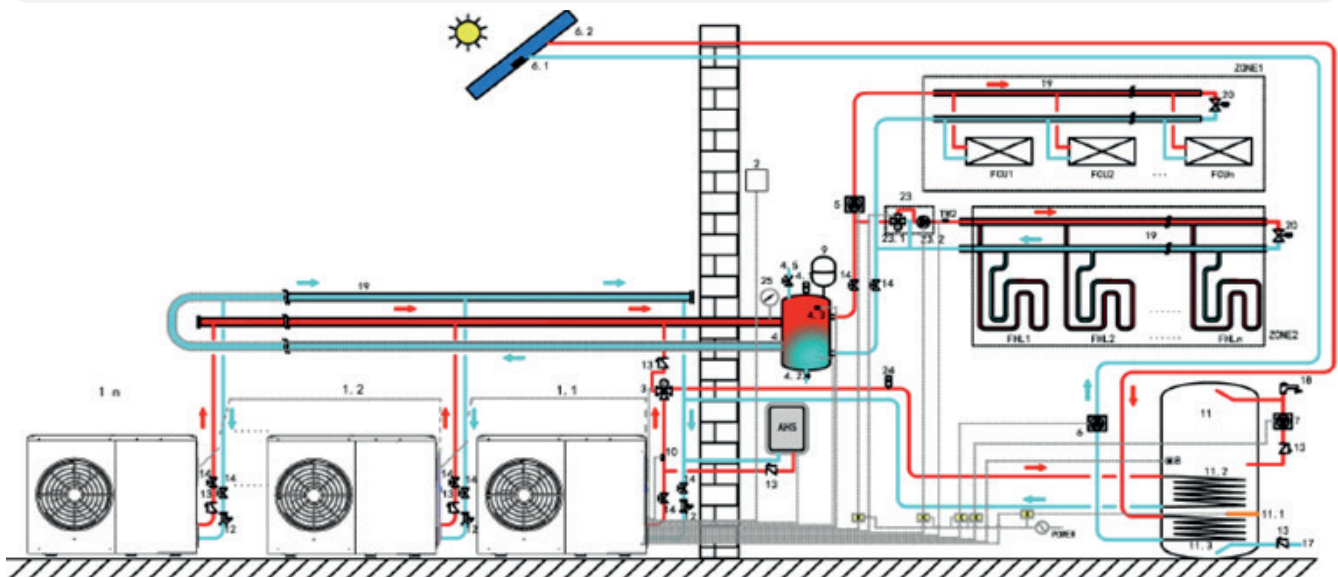

Air heat pumps with natural refrigerant MLP

RATED TECHNICAL DATA

MLP			006HM	008HM	010HM
Power supply		V-ph-Hz		230-1-50	
Cooling capacity	(1)(E)	kW	6,80	7,50	8,90
Total power input	(1)(E)	kW	2,19	2,17	2,74
EER	(1)(E)		3,10	3,45	3,25
SEER	(2)(E)		5,32	5,86	5,55
η_{sc}	(2)(E)		210	231	219
Water flow	(1)	l/h	1170	1290	1531
Available pressure head - LP pumps	(1)(E)	kPa	84	82	77
Heating capacity	(3)(E)	kW	6,40	8,20	10,0
Total power input	(3)(E)	kW	1,68	2,13	2,74
COP	(3)(E)		3,80	3,85	3,65
SCOP	(4)(E)		4,89	5,19	5,07
η_{sh}	(4)(E)		193	204	200
Heating energy efficiency class	(5)			A+++	
SCOP	(6)(E)		3,82	3,82	3,82
η_{sh}	(6)(E)		150	150	150
Heating energy efficiency class	(7)			A++	
Water flow	(3)	l/h	1101	1410	1720
Available pressure head - LP pumps	(3)(E)	kPa	85	80	70
Cooling capacity	(8)(E)	kW	6,50	8,30	10,0
Total power input	(8)(E)	kW	1,27	1,61	2,11
EER	(8)(E)		5,10	5,15	4,75
Heating capacity	(9)(E)	kW	6,20	8,40	10,0
Total power input	(9)(E)	kW	1,27	1,68	2,13
COP	(9)(E)		4,90	5,00	4,69
Maximum current absorption		A	15,0	19,0	19,0
Expansion vessel volume		dm ³	8	8	8
Sound power level	(10)(E)	dB(A)	58	60	61
Operating weight - unit with pump		kg	90	117	117

(1) Outdoor air temperature 35°C, water temperature 12°C / 7°C (EN14511:2022)

(2) η efficiency values for heating and cooling are respectively calculated by the following formulas: $[\eta = SCOP / 2,5 - F(1) - F(2)]$ e $[\eta = SEER / 2,5 - F(1) - F(2)]$. For further information, please refer to the technical document "ErP 2009/125/EC DIRECTIVE" in the catalogue introducing pages, or to the EN14825:2022 regulation.

(3) Outdoor air temperature dry bulb 7°C / wet bulb 6°C, water temperature 40°C / 45°C (EN14511:2022)

(4) η efficiency values for heating and cooling are respectively calculated by the following formulas: $[\eta = SCOP / 2,5 - F(1) - F(2)]$ e $[\eta = SEER / 2,5 - F(1) - F(2)]$. For further information, please refer to the technical document "ErP 2009/125/EC DIRECTIVE" in the catalogue introducing pages, or to the EN14825:2022 regulation. Low temperature conditions.

(5) Seasonal energy efficiency class for LOW TEMPERATURE room heating under AVERAGE climatic conditions [EUROPEAN REGULATION No 811/2013]

(6) η efficiency values for heating and cooling are respectively calculated by the following formulas: $[\eta = SCOP / 2,5 - F(1) - F(2)]$ e $[\eta = SEER / 2,5 - F(1) - F(2)]$. For further information, please refer to the technical document "ErP 2009/125/EC DIRECTIVE" in the catalogue introducing pages, or to the EN14825:2022 regulation. Medium temperature conditions.

(7) Seasonal energy efficiency class for MEDIUM TEMPERATURE room heating under AVERAGE climatic conditions [EUROPEAN REGULATION No 811/2013]

(8) Outdoor air temperature 35°C, water temperature 23°C / 18°C (EN14511:2022)

(9) Outdoor air temperature dry bulb 7°C / wet bulb 6°C, water temperature 30°C / 35°C (EN14511:2022)

(10) Sound power level measured according to ISO 9614

(E) EUROVENT certified data

RATED TECHNICAL DATA

MLP			012H0	012HM	016H0
Power supply		V-ph-Hz	400-3N-50	230-1-50	400-3N-50
Cooling capacity	(1)(E)	kW	11,5	11,5	14,0
Total power input	(1)(E)	kW	3,77	3,77	5,09
EER	(1)(E)		3,05	3,05	2,75
SEER	(2)(E)		5,19	5,19	5,12
η_{sc}	(2)(E)		204	204	202
Water flow	(1)	l/h	1978	1978	2408
Available pressure head - LP pumps	(1)(E)	kPa	64	64	49
Heating capacity	(3)(E)	kW	12,0	12,0	15,0
Total power input	(3)(E)	kW	3,24	3,24	4,48
COP	(3)(E)		3,70	3,70	3,35
SCOP	(4)(E)		4,67	4,67	4,59
η_{sh}	(4)(E)		184	184	181
Heating energy efficiency class	(5)			A+++	
SCOP	(6)(E)		3,62	3,62	3,57
η_{sh}	(6)(E)		142	142	140
Heating energy efficiency class	(7)			A++	
Water flow	(3)	l/h	2064	2064	2580
Available pressure head - LP pumps	(3)(E)	kPa	61	61	44
Cooling capacity	(8)(E)	kW	12,0	12,0	16,0
Total power input	(8)(E)	kW	2,67	2,67	4,10
EER	(8)(E)		4,50	4,50	3,90
Heating capacity	(9)(E)	kW	12,0	12,0	15,0
Total power input	(9)(E)	kW	2,50	2,50	3,41
COP	(9)(E)		4,80	4,80	4,40
Maximum current absorption		A	11,0	31,0	11,0
Expansion vessel volume		dm ³	8	8	8
Sound power level	(10)(E)	dB(A)	65	65	69
Operating weight - unit with pump		kg	137	135	137

(1) Outdoor air temperature 35°C, water temperature 12°C / 7°C (EN14511:2022)

(2) η efficiency values for heating and cooling are respectively calculated by the following formulas: [$\eta = SCOP / 2,5 - F(1) - F(2)$] e [$\eta = SEER / 2,5 - F(1) - F(2)$]. For further information, please refer to the technical document "ErP 2009/125/EC DIRECTIVE" in the catalogue introducing pages, or to the EN14825:2022 regulation.

(3) Outdoor air temperature dry bulb 7°C / wet bulb 6°C, water temperature 40°C / 45°C (EN14511:2022)

(4) η efficiency values for heating and cooling are respectively calculated by the following formulas: [$\eta = SCOP / 2,5 - F(1) - F(2)$] e [$\eta = SEER / 2,5 - F(1) - F(2)$]. For further information, please refer to the technical document "ErP 2009/125/EC DIRECTIVE" in the catalogue introducing pages, or to the EN14825:2022 regulation. Low temperature conditions.

(5) Seasonal energy efficiency class for LOW TEMPERATURE room heating under AVERAGE climatic conditions [EUROPEAN REGULATION No 811/2013]

(6) η efficiency values for heating and cooling are respectively calculated by the following formulas: [$\eta = SCOP / 2,5 - F(1) - F(2)$] e [$\eta = SEER / 2,5 - F(1) - F(2)$]. For further information, please refer to the technical document "ErP 2009/125/EC DIRECTIVE" in the catalogue introducing pages, or to the EN14825:2022 regulation. Medium temperature conditions.

(7) Seasonal energy efficiency class for MEDIUM TEMPERATURE room heating under AVERAGE climatic conditions [EUROPEAN REGULATION No 811/2013]

(8) Outdoor air temperature 35°C, water temperature 23°C / 18°C (EN14511:2022)

(9) Outdoor air temperature dry bulb 7°C / wet bulb 6°C, water temperature 30°C / 35°C (EN14511:2022)

(10) Sound power level measured according to ISO 9614

(E) EUROVENT certified data

Air heat pumps with natural refrigerant MLP

RATED TECHNICAL DATA

MLP			016HM	026H0	030H0
Power supply		V-ph-Hz	230-1-50	400-3N-50	400-3N-50
Cooling capacity	(1)(E)	kW	14,0	26,0	30,0
Total power input	(1)(E)	kW	5,09	8,40	10,7
EER	(1)(E)		2,75	3,10	2,80
SEER	(2)(E)		5,12	5,21	4,99
η_{sc}	(2)(E)		202	205	197
Water flow	(1)	l/h	2408	4472	5160
Available pressure head - LP pumps	(1)(E)	kPa	49	71	54
Heating capacity	(3)(E)	kW	15,0	26,0	30,0
Total power input	(3)(E)	kW	4,48	6,82	8,26
COP	(3)(E)		3,35	3,81	3,63
SCOP	(4)(E)		4,59	4,95	4,92
η_{sh}	(4)(E)		181	195	194
Heating energy efficiency class	(5)			A+++	
SCOP	(6)(E)		3,57	3,84	3,79
η_{sh}	(6)(E)		140	151	149
Heating energy efficiency class	(7)		A++	A+++	A++
Water flow	(3)	l/h	2580	4472	5160
Available pressure head - LP pumps	(3)(E)	kPa	44	71	54
Cooling capacity	(8)(E)	kW	16,0	26,0	30,0
Total power input	(8)(E)	kW	4,10	5,60	6,80
EER	(8)(E)		3,90	4,64	4,41
Heating capacity	(9)(E)	kW	15,0	26,0	30,0
Total power input	(9)(E)	kW	3,41	5,45	6,67
COP	(9)(E)		4,40	4,77	4,50
Maximum current absorption		A	31,0	35,0	35,0
Expansion vessel volume		dm ³	8	5	5
Sound power level	(10)(E)	dB(A)	69	69	74
Operating weight - unit with pump		kg	135	260	260

(1) Outdoor air temperature 35°C, water temperature 12°C / 7°C (EN14511:2022)

(2) η efficiency values for heating and cooling are respectively calculated by the following formulas: $[\eta = SCOP / 2,5 - F(1) - F(2)]$ e $[\eta = SEER / 2,5 - F(1) - F(2)]$. For further information, please refer to the technical document "ErP 2009/125/EC DIRECTIVE" in the catalogue introducing pages, or to the EN14825:2022 regulation.

(3) Outdoor air temperature dry bulb 7°C / wet bulb 6°C, water temperature 40°C / 45°C (EN14511:2022)

(4) η efficiency values for heating and cooling are respectively calculated by the following formulas: $[\eta = SCOP / 2,5 - F(1) - F(2)]$ e $[\eta = SEER / 2,5 - F(1) - F(2)]$. For further information, please refer to the technical document "ErP 2009/125/EC DIRECTIVE" in the catalogue introducing pages, or to the EN14825:2022 regulation. Low temperature conditions.

(5) Seasonal energy efficiency class for LOW TEMPERATURE room heating under AVERAGE climatic conditions [EUROPEAN REGULATION No 811/2013]

(6) η efficiency values for heating and cooling are respectively calculated by the following formulas: $[\eta = SCOP / 2,5 - F(1) - F(2)]$ e $[\eta = SEER / 2,5 - F(1) - F(2)]$. For further information, please refer to the technical document "ErP 2009/125/EC DIRECTIVE" in the catalogue introducing pages, or to the EN14825:2022 regulation. Medium temperature conditions.

(7) Seasonal energy efficiency class for MEDIUM TEMPERATURE room heating under AVERAGE climatic conditions [EUROPEAN REGULATION No 811/2013]

(8) Outdoor air temperature 35°C, water temperature 23°C / 18°C (EN14511:2022)

(9) Outdoor air temperature dry bulb 7°C / wet bulb 6°C, water temperature 30°C / 35°C (EN14511:2022)

(10) Sound power level measured according to ISO 9614

(E) EUROVENT certified data

DIMENSIONAL DRAWINGS

MLP 006

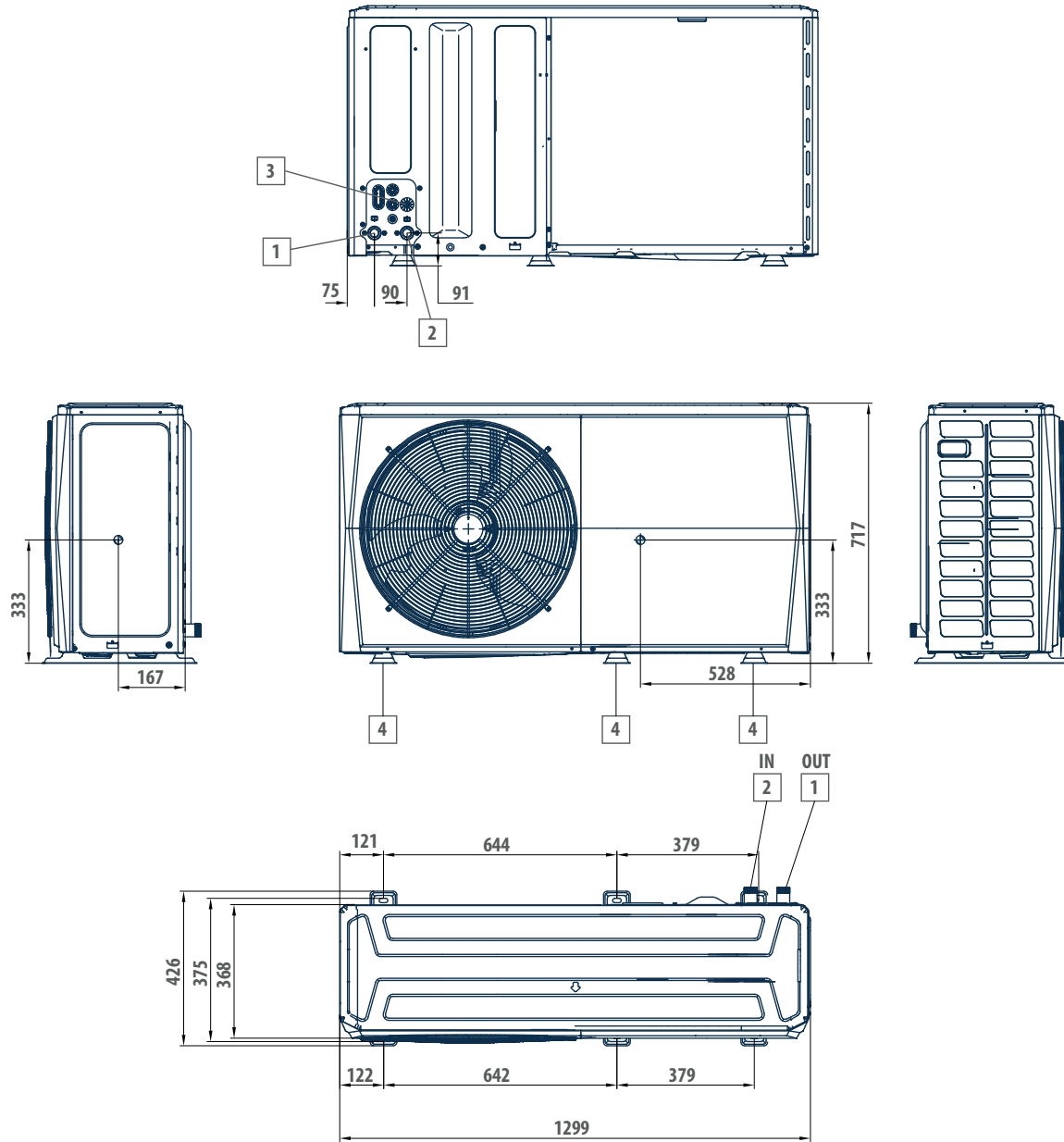

LEGEND

- | | |
|---|-----------------------------|
| 1 | Water outlet user 1" |
| 2 | Water inlet on user side 1" |
| 3 | Outlet safety valve 16 mm |
| 4 | Vibration dampers |

Air heat pumps with natural refrigerant MLP

DIMENSIONAL DRAWINGS

MLP 008-016

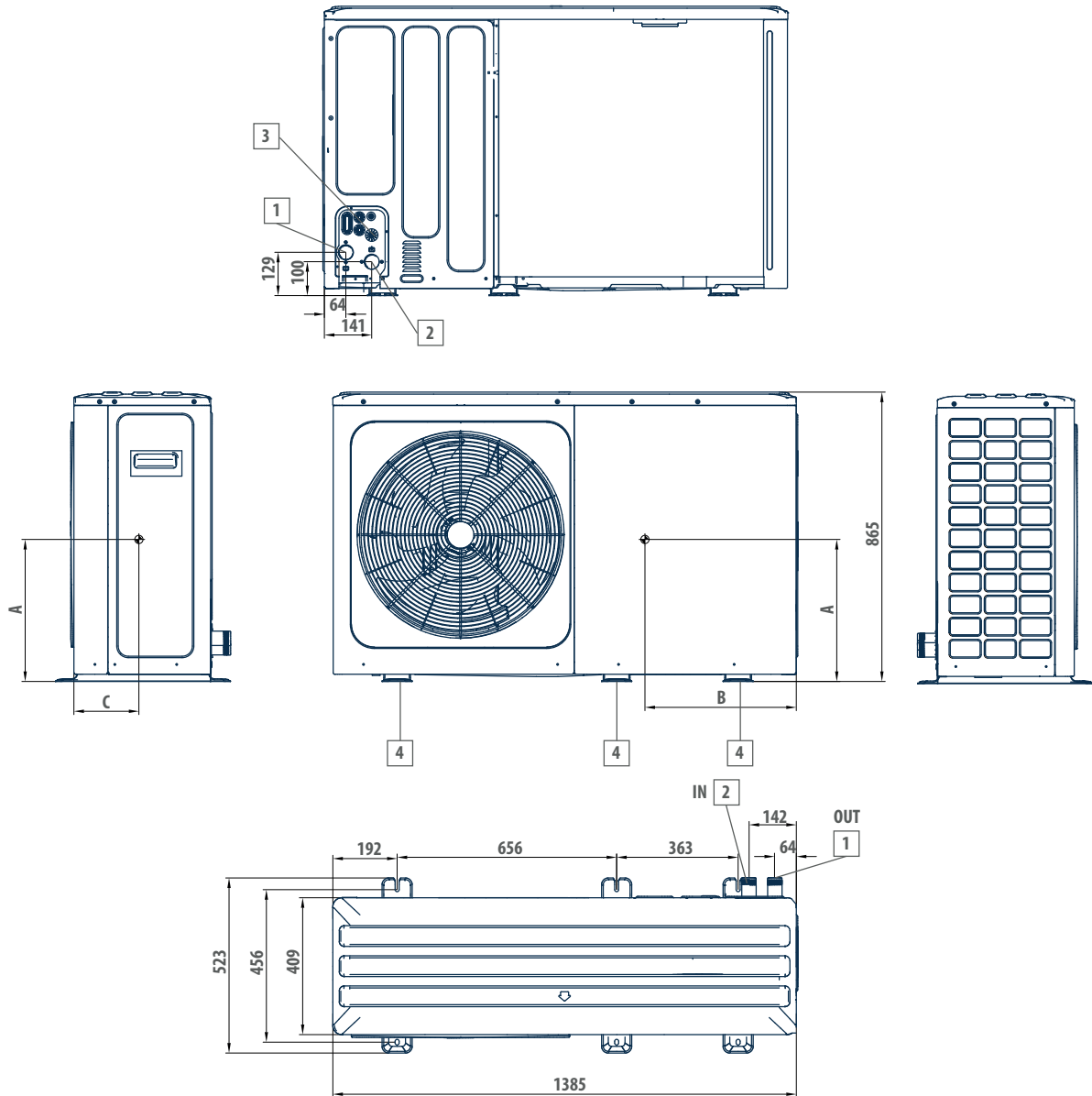

LEGEND

- 1 Water outlet user 1 1/4"
- 2 Water inlet on user side 1 1/4"
- 3 Outlet safety valve 16 mm
- 4 Vibration dampers

Mod.	A mm	B mm	C mm
MLP008HM	360	550	234
MLP010HM	360	550	234
MLP012HM	415	715	200
MLP012H0	415	715	200
MLP016HM	415	715	200
MLP016H0	415	715	200

DIMENSIONAL DRAWINGS

MLP 026-030

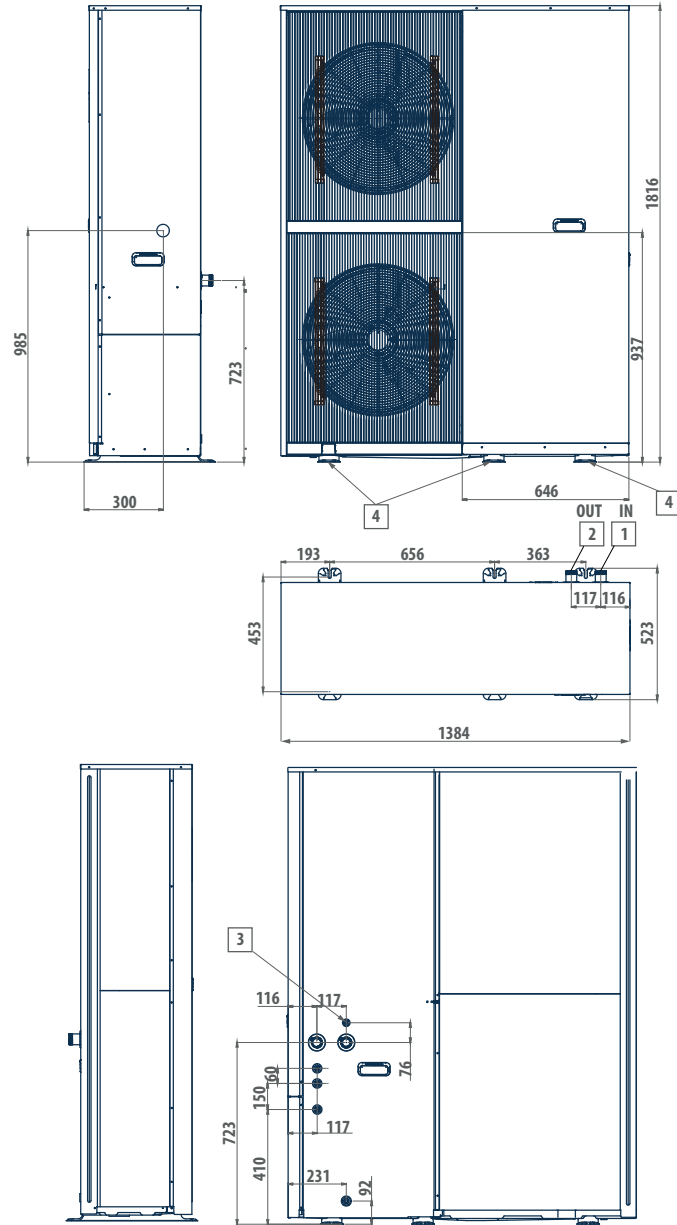

LEGEND

1	Water outlet user 1 1/4"
2	Water inlet on user side 1 1/4"
3	Outlet safety valve 16 mm
4	Vibration dampers

PLP Chillers and Inverter HP with natural refrigerant

Outdoor packaged unit with R290

PLP 37 - 63 kW



Heat pumps with inverter compressor and low GWP refrigerant

The reduction of polluting emissions, whether directly related to the use of greenhouse gases or more indirectly related to emissions from the production of electricity used during the lifetime of a heat pump, is the first and most important pillar on which Galletti has based its Advanced Design approach.

This has led to the creation of PLP, a new range of natural refrigerant air/water units with inverter compressors. Its extremely wide operating range and high performance under all operating conditions make it the perfect answer to the need to phase out the use of fossil fuels for heating and cooling buildings.

Thanks to the high temperature of the water produced (up to 80°C), we can replace a fossil fuel generator while maintaining the full performance of the existing emissions system.

By taking advantage of the continuous modulation of compressor capacity, we produce exactly what is needed to keep people comfortable, no more and no less, without waste, working to maximise the efficiency of the whole system.

We look to the future of our environment as well as the needs of the people who use our products.

We work every day to make indoor comfort more sustainable.

PLUS

- R290 refrigerant (GWP=3)
- Inverter driven variable speed scroll compressor
- Production of hot water up to 80°C
- Full load operation down to -20°C air (60°C water)
- Very high seasonal efficiency values SCOP up to 4,50 and SEER up to 5,24)
- Power output and COP monitoring (option)
- Availability of silenced setups

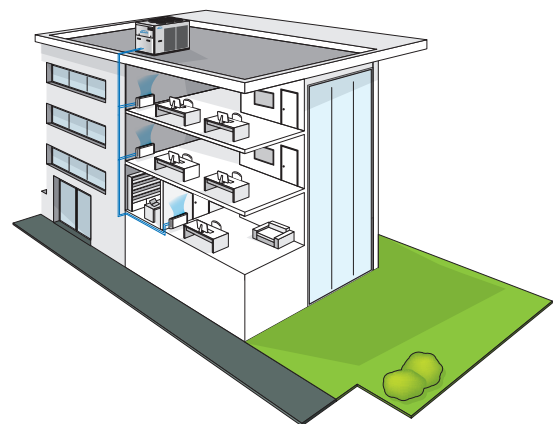

PLP heat pumps and water chillers are designed for heating or cooling the water to be used in air-conditioning systems for residential, commercial or industrial use.

The use of the natural refrigerant R290 (propane) ensures compliance with the more stringent limits imposed by the F-GAS regulation regarding gases with a potential contribution to global warming (greenhouse gases).



CONFIGURATOR

The models are completely configurable by selecting the version and the options. To the right is shown an example of configuration.

Version	Field	1	2	3	4	5	6	7	8	9	10	11	12	13	14	15
PLP057HS2A		A	1	S	0	E	E	0	0	0	I	G	0	1	0	1

To verify the compatibility of the options, use the selection software or the price list.

AVAILABLE VERSIONS

Only cooling versions

- PLP.CS2A Power supply 400V-3N-50Hz + circuit breaker
- PLP.CS5A Power supply 400V-3N-50Hz + circuit breaker + transformer

Reversible heat pump versions

- PLP.HS2A Power supply 400V-3-50Hz + circuit breaker
- PLP.HS5A Power supply 400V-3N-50Hz + circuit breaker + transformer

CONFIGURATION OPTIONS

- | | |
|---|--|
| <p>1 Expansion valve</p> <ul style="list-style-type: none"> A Electronic valve <p>2 Water pump and accessories</p> <ul style="list-style-type: none"> 0 Absent 1 Single standard pump 2 Standard dual OR pump 3 Single HP pump 4 Dual HP OR pump 5 Standard single pump with Viton seal 6 Standard dual OR pump with Viton seal 7 Single HP pump with Viton seal 8 Dual HP OR pump with Viton seal A Single inverter standard pump B Standard dual inverter OR pump C Inverter Single HP pump D Dual inverter HP OR pump E Standard single inverter pump with Viton seal F Standard dual inverter OR pump with Viton seal G Single inverter HP pump with Viton seal H Dual inverter HP OR pump with Viton seal <p>3 Water buffer tank</p> <ul style="list-style-type: none"> 0 Absent S Selected <p>4 De-superheater</p> <ul style="list-style-type: none"> 0 Absent D Included with pump free contact <p>5 Condensation/Evaporation Control</p> <ul style="list-style-type: none"> C Phase-cut (up to size 57) E With EC Fans (available for all models, standard only on 62) <p>6 Antifreezing kit</p> <ul style="list-style-type: none"> E Plate exchangers only P Plate exchanger and pump S For plate exchanger, pump and tank T For plate exchanger and tank <p>7 Acoustic insulation and attenuation</p> <ul style="list-style-type: none"> 0 Absent | <ul style="list-style-type: none"> 2 Compressor soundproof insulation 5 Compressor soundproof insulation + low-noise fans <p>8 Refrigeration circuit options</p> <ul style="list-style-type: none"> 0 Absent <p>9 Remote control</p> <ul style="list-style-type: none"> 0 Absent 2 RS485 connection port (Modbus protocol or Carel) B BACNET IP / pCOWeb serial board G BACNET IP / pCOWeb serial board + supervision software S Simplified additional remote control panel X Additional remote control for advanced control (up to 50m) <p>10 Special coils / Protective treatments</p> <ul style="list-style-type: none"> C Cataphoresis (only for HP versions) E Microchannel in Long Life Alloy (standard for chiller) I Hydrophilic (standard for HP, only for HP versions) M Microchannel con e-coating (solo versione C) P Pre-painted fins with epoxy painting (only HP versions) R Rame-rame (solo versione H) <p>11 Base vibration dampers</p> <ul style="list-style-type: none"> 0 Absent G Made of rubber M With spring <p>12 Outdoor coil trace heater</p> <ul style="list-style-type: none"> 0 Absent 1 Present (only HP versions) <p>13 Control panel</p> <ul style="list-style-type: none"> 1 Advanced <p>14 Water flow control</p> <ul style="list-style-type: none"> 1 Water differential pressure switch 3 Hot-wire electronic flow switch <p>15 DHW accessory only (if option 3 = 0)</p> <ul style="list-style-type: none"> 0 Absent 1 3-way DHW valve + DHW tank probe 2 DHW mode enabling with dry contact 3 DHW 3-way valve + DHW mode enabling with dry contact |
|---|--|

ACCESSORIES

B	Outdoor finned coil heat exchanger protection grille	N	Integration system enabling contact (boiler / electric heater) plant
C	Smart Grid Certification (excludes accessory E)	O	Night-time low-noise (only if opt 7 is different from 5)
D	ON/OFF status of the compressors (mandatory only if opt.4 = D)	Q	Temperature probe for pump shutdown on the primary circuit
E	Remote control for power step limits (excludes accessories C)	R	Enabling 2nd set-point
F	Configurable digital alarm board	T	Mains power analyzer for monitoring of power consumption
G	Air separator for the water system (supplied loose)	U	Unit lifting pipes
H	Dirt separator for the water system (supplied loose)	V	Set-point modification with 4-20mA signal
I	Refrigerant sensors (standard)	Z	Flow meter for calculating power output
L	Double insulation water side (as standard for tank)	1	Integration system enabling contact (electric heater) DHW (only if opt 15 different from 0)
M	0-10V signal for external user pump control (only if opt 2=0)	2	Outdoor finned coil heat exchanger protection filters

PLP Chillers and Inverter HP with natural refrigerant

Natural refrigerant (R290)

R290 (propane) is a natural refrigerant with a GWP (Global Warming Potential) of only 3. This makes it a strong contender to be one of the leading refrigerants for air conditioning solutions. It has a much lower contribution to the greenhouse effect than synthetic refrigerants and physical properties that make it ideal for the design requirements associated with the ever-increasing use of heat pumps.

Inverter scroll compressors

The inverter scroll compressor used is part of the fourth and latest generation of scroll compressors offering a variable speed solution. In addition to the advantages offered by the technology (precise cooling and humidity management, low starting current, precise and seasonal energy efficiency), these compressors are equipped with specific features that add value to the PLP range. These include intermediate discharge valves, which increase efficiency at low compression ratios and further improve partial-load efficiency, and permanent magnet brushless motors.

EXTENDED OPERATING RANGE FOR EACH APPLICATION

Extremely extended operating limits

It is now clear that heat pumps will play a fundamental role in achieving the objectives of the European Green Deal, first and foremost the phasing out of fossil fuels. One of the basic requirements for the heat pump to be considered as a valid alternative to boilers, even in the most hostile climates, is undoubtedly the extension of the operating limits that have characterised the traditional heat pumps used until now.

Thanks to the use of scroll inverter technology, combined with the use of propane as a refrigerant and the innovative solutions developed by Galletti's Advanced Design Unit during the design and prototyping phase, PLP guarantees the possibility of producing hot water at very high temperatures (up to 80°C) and operating at full load at extremely low outdoor temperatures (down to -20°C).

In this way (given the temperatures of the water produced, which cannot be achieved with traditional heat pumps), we can imagine replacing a combustion generator with an R290 heat pump, even if the insulation work on the casing is postponed to a later stage. This makes it possible to significantly increase the proportion of renewable energy used for heating without compromising indoor comfort. Advanced Design's solutions look to the future of our environment and the needs of the people who use our products.

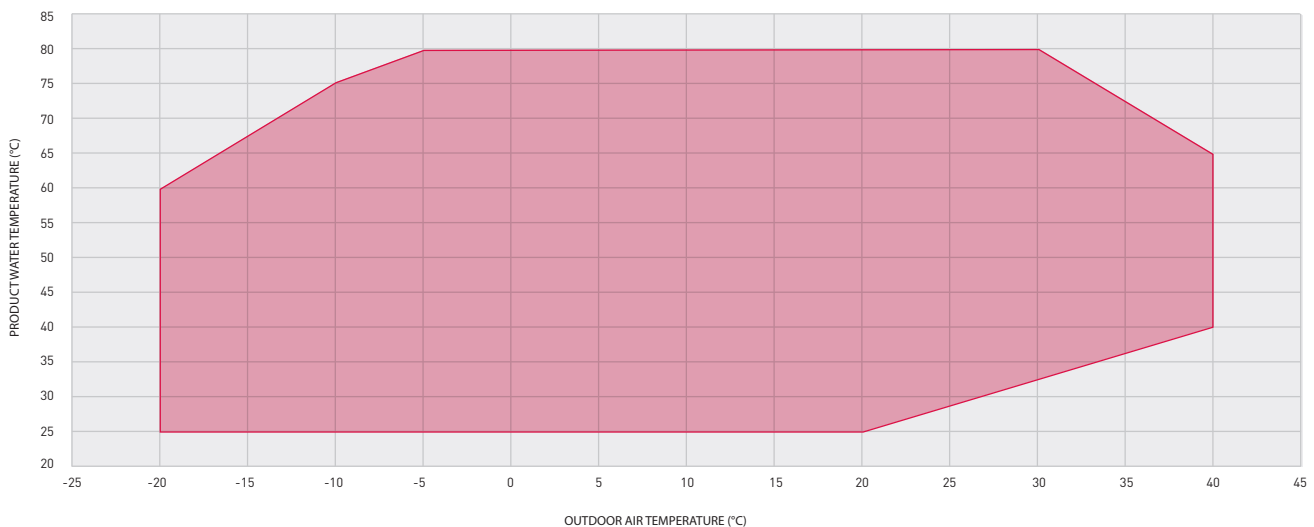

PLP C WATER CHILLERS RATED TECHNICAL DATA

PLP			037	045	052	057	062
Power supply		V-ph-Hz	400-3N-50				
Cooling capacity	(1)(E)	kW	36,0	41,4	46,7	51,2	57,1
Total power input	(1)(E)	kW	12,0	14,0	16,4	18,1	19,2
EER	(1)(E)		3,01	2,97	2,84	2,83	2,97
SEER	(2)(E)		5,00	4,88	5,02	5,02	5,24
Water flow	(1)	l/h	6201	7140	8038	8814	9843
Water pressure drop	(1)(E)	kPa	37	50	37	44	45
Available pressure head - LP pumps	(1)	kPa	125	89	120	113	111
Available pressure head - HP pumps	(1)	kPa	213	173	205	199	196
Compressors / circuits			1/1				
Maximum current absorption		A	42,0	48,0	56,0	59,0	62,0
Start up current		A	43	50	57	61	63
Buffer tank volume		dm ³	125	125	125	125	125
Sound power level	(3)(E)	dB(A)	82	83	83	83	84
Sound power level, low-noise version	(3)	dB(A)	79	80	80	80	81
Weight without options		kg	449	449	456	456	538
Maximum transport weight		kg	567	567	586	586	686

(1) Outdoor air temperature 35°C, water temperature 12°C / 7°C (EN14511:2022)

(2) η efficiency values for heating and cooling are respectively calculated by the following formulas: $[\eta = SCOP / 2,5 - F(1) - F(2)]$ e $[\eta = SEER / 2,5 - F(1) - F(2)]$. For further information, please refer to the technical document "ErP 2009/125/EC DIRECTIVE" in the catalogue introducing pages, or to the EN14825:2022 regulation.

(3) Sound power level measured according to ISO 9614

(E) EUROVENT certified data

PLP Chillers and Inverter HP with natural refrigerant

HEAT PUMPS RATED TECHNICAL DATA PLP H

PLP			037	045	052	057	062
Power supply		V-ph-Hz	400-3-50				
Cooling capacity	(1)(E)	kW	30,0	35,7	41,6	45,5	50,3
Total power input	(1)(E)	kW	12,0	14,4	16,8	18,2	19,3
EER	(1)(E)		2,49	2,48	2,48	2,50	2,60
SEER	(2)(E)		4,32	4,24	4,15	4,12	4,45
Water flow	(1)	l/h	5165	6143	7155	7832	8653
Water pressure drop	(1)(E)	kPa	28	39	30	34	36
Available pressure head - LP pumps	(1)	kPa	145	114	131	126	123
Available pressure head - HP pumps	(1)	kPa	234	200	217	211	209
Heating capacity	(3)(E)	kW	37,2	45,7	52,5	57,1	63,0
Total power input	(3)(E)	kW	11,0	13,8	15,8	17,3	18,8
COP	(3)(E)		3,37	3,31	3,32	3,31	3,35
SCOP	(4)(E)		4,50	4,20	4,35	4,25	4,49
Heating energy efficiency class	(5)(E)		A+++	A++	A++	A++	A++
Water flow	(3)	l/h	6442	7906	9087	9887	10903
Water pressure drop	(3)(E)	kPa	44	62	48	56	60
Available pressure head - LP pumps	(3)	kPa	114	70	108	101	93
Available pressure head - HP pumps	(3)	kPa	200	154	193	185	178
Maximum current absorption		A	42,0	48,0	56,0	59,0	62,0
Compressors / circuits			1/1				
Buffer tank volume		dm ³	125	125	125	125	125
Sound power level	(6)(E)	dB(A)	82	83	83	83	84
Sound power level, low-noise version	(6)	dB(A)	79	80	80	80	81
Weight without options		kg	495	495	500	500	535
Maximum transport weight		kg	625	625	635	635	695

(1) Outdoor air temperature 35°C, water temperature 12°C / 7°C (EN14511:2022)

(2) η efficiency values for heating and cooling are respectively calculated by the following formulas: $[\eta = SCOP / 2,5 - F(1) - F(2)]$ e $[\eta = SEER / 2,5 - F(1) - F(2)]$. For further information, please refer to the technical document "ErP 2009/125/EC DIRECTIVE" in the catalogue introducing pages, or to the EN14825:2022 regulation.

(3) Outdoor air temperature dry bulb 7°C / wet bulb 6°C, water temperature 40°C / 45°C (EN14511:2022)

(4) η efficiency values for heating and cooling are respectively calculated by the following formulas: $[\eta = SCOP / 2,5 - F(1) - F(2)]$ e $[\eta = SEER / 2,5 - F(1) - F(2)]$. For further information, please refer to the technical document "ErP 2009/125/EC DIRECTIVE" in the catalogue introducing pages, or to the EN14825:2022 regulation. Low temperature conditions.

(5) Seasonal energy efficiency class for LOW TEMPERATURE room heating under AVERAGE climatic conditions [EUROPEAN REGULATION No 811/2013. The energy efficiency class of this product is included in the range A+++ → D]

(6) Sound power level measured according to ISO 9614

(E) EUROVENT certified data

DIMENSIONAL DRAWINGS

PLP 037 - 057

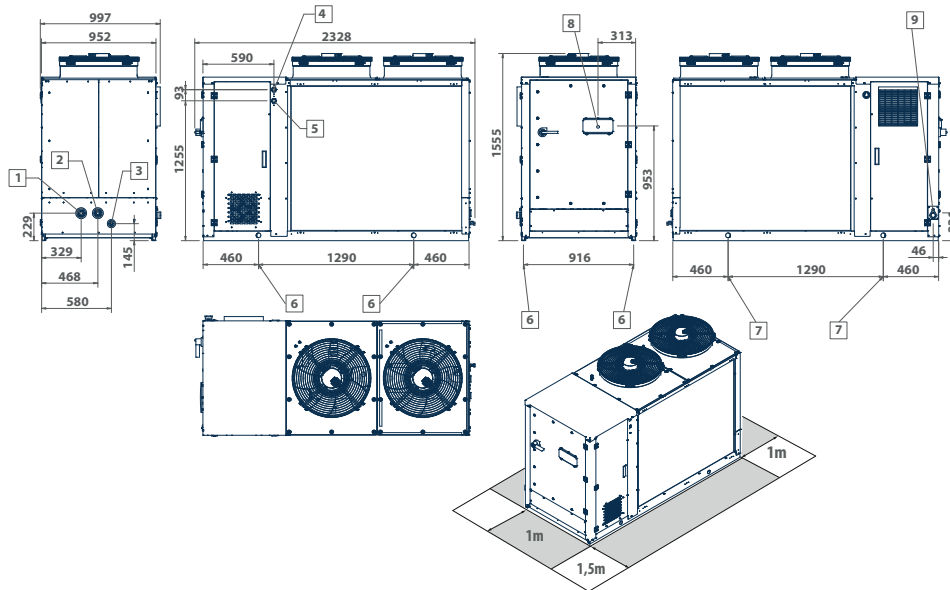

LEGEND

1	Water inlet 1" 1/4 F (037-045) and 1" 1/2 F (052-057)	6	Vibration dumpers
2	Water outlet 1" 1/4 F (037-045) and 1" 1/2 F (052-057)	7	Lifting points
3	Water drainage 1/2" F	8	User interface
4	Desuperheater water inlet 1" F	9	Power supply input
5	De-superheater water outlet 1" F		

PLP 062

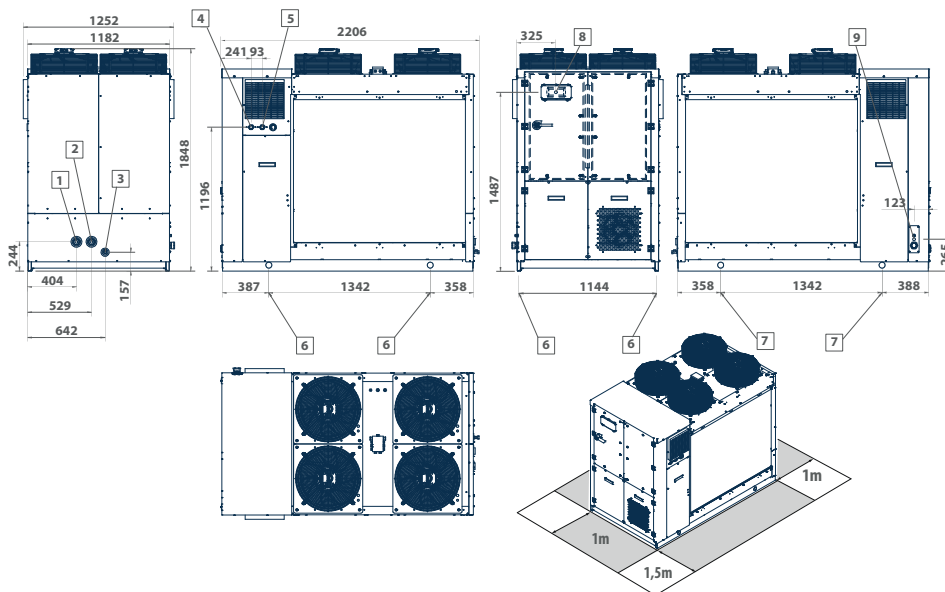

LEGEND

1	Water inlet 1" 1/2 F	6	Vibration dumpers
2	Water outlet 1" 1/2 F	7	Lifting points
3	Water drainage 1/2" F	8	User interface
4	Desuperheater water inlet 1" F	9	Power supply input
5	De-superheater water outlet 1" F		

PLI Inverter Chillers and HP with Low GWP refrigerant



High-efficiency full inverter compact outdoor packaged units

PLI 35 - 55 kW

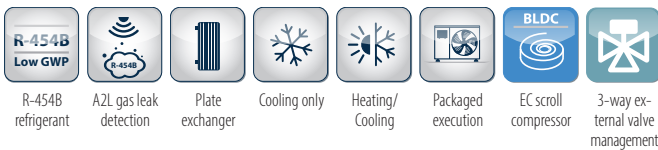

PLUS

- » Refrigerant with GWP of less than 500
- » Inverter driven variable speed scroll compressor
- » Reduced refrigerant charge thanks to the use of micro-channel (C versions) or mini-channel (H versions) coils
- » Production of water from -10°C to 60°C
- » High seasonal efficiency values (ErP 2021 compliant)
- » Electronic expansion valve as standard
- » High configurability and wide availability of accessories
- » Availability of standard acoustic execution or in silenced configuration

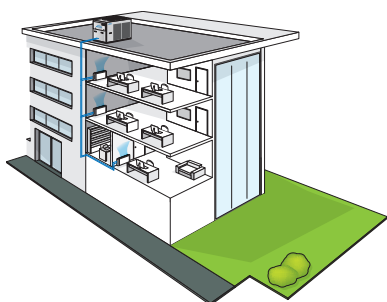

Heat pumps with inverter compressor and low GWP refrigerant

PLI is Galletti's new range of air-cooled packaged chillers and heat pumps for outdoor installation featuring with inverter-driven modulating scroll compressor and R454B refrigerant. R454B is a next generation A2L refrigerant with a GWP of only 467, one of the lowest on the market. This GWP value ensures that the PLI range complies with the gradual reduction of greenhouse gas emissions required by the F-GAS regulation, down to the stricter limits foreseen for 2030.

Not only that, the use of finned coils with reduced diameters for the passage of the refrigerant (micro-channels for only cooling versions and mini-channels for reversible heat pumps) allows a reduction of the refrigerant charge by more than 50% compared to similar products with same capacity but with standard technology.

The range consists of 4 models with cooling capacities from 35 to 50 kW, available as cooling only and reversible heat pump mode. The inverter controller allows to adjust the capacity and the input of the compressor to the actual thermal load and makes it possible to considerably reduce electrical intakes at the compressor start-up (reduction of starting currents) and during the operation under partial loads.

The use of top quality components at the cutting edge of technology in the cooling, hydraulic, and electrical systems makes PLI chillers state of the art in terms of efficiency, reliability, and operating limits. In fact, the ability to produce water from -10°C to 60°C, and full load operation with external air from -15°C to 48°C.

The range allows high configurability from an acoustic and hydraulic point of view, having ample accessories designed to meet installation needs characterized by reduced overall dimensions: without increasing the size it is possible to provide on board the storage tank and up to a maximum of two hydraulic pumps.

Advanced control, which is always provided across the entire range, allows continuous monitoring of operating parameters, advanced regulation logics, and connectivity.

PLI heat pumps and water chillers are designed for heating or cooling the water to be used in air-conditioning systems for residential, commercial, or industrial use.

The use of low-GWP refrigerant ensures compliance with the limits established by the F-GAS regulation regarding gases that potentially contribute to global warming (greenhouse gases).

CONFIGURATOR

The models are completely configurable by selecting the version and the options. To the right is shown an example of configuration.

Version	Field	1	2	3	4	5	6	7	8	9	10	11	12	13
PLI050H50A		A	1	S	0	E	0	0	2	0	0	G	0	1

To verify the compatibility of the options, use the selection software or the price list.

AVAILABLE VERSIONS

Only cooling versions

PLI..CS0A	Power supply 400V-3N-50Hz
PLI..CS2A	Power supply 400V-3N-50Hz + circuit breaker
PLI..CS4A	Power supply 400V-3-50Hz + transformer
PLI..CS5A	Power supply 400V-3N-50Hz + circuit breaker + transformer

Reversible heat pump versions

PLI..HS0A	Power supply 400V-3-50Hz
PLI..HS2A	Power supply 400V-3-50Hz + circuit breaker
PLI..HS4A	Power supply 400V-3-50Hz + transformer
PLI..HS5A	Power supply 400V-3N-50Hz + circuit breaker + transformer

CONFIGURATION OPTIONS

1 Expansion valve		0 Absent
A Electronic		3 Compressor compartment acoustic insulation and sound blanket
2 Water pump and accessories		8 Refrigerant pipework accessories
0 Absent		0 Absent
1 Single standard pump		9 Remote control / Serial communication
2 Double standard pump OR		0 Absent
3 Single HP pump		2 RS485 connection port (Modbus protocol or Carel)
4 HP OR double pump		B BACNET IP / pCOWeb serial board
A Single standard pump Inverter		G BACNET IP / pCOWeb serial board + supervision software
B Double standard pump Inverter OR		S Remote simplified control panel
C Inverter Single HP pump		X Remote control panel for advanced controller
D HP OR inverter double pump		10 Special coils / Protective treatments
3 Water buffer tank		0 Copper-aluminium (standard heat pump only)
0 Absent		C Cataphoresis treatment on fins and coil carpentry
S Selected		E Microchannel in Long Life Alloy (standard for chiller)
4 Partial heat recovery		I Hydrophilic (heat pump only)
0 Absent		M Microchannel with e-coating (chiller only)
D Included with pump free contact		P Pre-painted fins with polyester paint (only heat pump)
5 Air flow modulation		R Copper-copper (heat pump only)
A with EC Fans high pressure head		11 Base vibration dampers
C Phase-cut		0 Absent
E with EC Fans		G Made of rubber
6 Antifreezing kit		M With spring
0 Absent		12 Outdoor coil trace heater
E Plate exchangers only		0 Absent
P Plate exchanger + pump + expansion vessel		1 Present (heat pump only)
S Plate exchanger + pump + expansion vessel and tank		13 Onboard controller
7 Acoustic insulation and attenuation		1 Advanced

ACCESSORIES

A	3 way valve for DHW production (water tank not allowed)	N	Compressor tandem/trio isolation valves
B	Outdoor finned coil heat exchanger protection grille	P	DHW request from digital input
D	ON/OFF status of the compressors	Q	Temperature probe for pump shutdown on the primary circuit
E	Remote control for step capacity limit (advanced controller required)	R	Enabling 2nd set-point / external alarm signaling via digital input
F	Configurable digital alarm board (advanced controller required)	T	Energy metering kit
I	Refrigerant sensors	U	Unit lifting pipes
L	Water pipes additional insulation	V	Set-point modification with 4-20mA signal
M	0-10 V signal for external user pump control (on-board pump excluded)	Z	Outdoor finned coil heat exchanger protection filters

MAIN COMPONENTS



Inverter scroll compressors

The Danfoss VZH inverter scroll compressor is part of the third and latest generation of scroll compressors offering variable speed technology. In addition to the advantages offered by the technology (precise cooling and humidity management, low starting current, energy efficiency, etc.), VZH scroll inverters have specific features that offer added value to the PLI range. These include Intermediate Relief Valves (IDV) which increase efficiency at low pressure ratios, further increasing efficiency at part load, and permanent magnet brushless motors. Not only that, the operational maps have been expanded to meet the needs of maximum efficiency for multiple applications in the HVAC world.

Fan

The sound levels are especially low thanks to the use of a specially designed fan with airfoil blades that is able to ensure a high air flow rate with limited noise emission.

PLI Inverter Chillers and HP with Low GWP refrigerant

Very low GWP refrigerant

Use of R454B refrigerant with low environmental impact. R454B is a next-generation A2L refrigerant with a GWP of only 467, one of the lowest on the market. This GWP value ensures that the PLI range complies with the gradual reduction of quotas of greenhouse refrigerants in the European market required by the F-GAS regulation, down to the stricter limits foreseen for 2030

Heat exchanger

Brazed-welded plate condenser in AISI 316 corrosion resistant austenitic stainless steel, specifically developed to maximise heat exchange coefficients between water and refrigerant.



EXTENDED OPERATING RANGE FOR EACH APPLICATION

PLI series heat pumps were designed to ensure maximum flexibility in every application. Thanks to their extremely wide operating range ensuring the operation even in particularly cold climates and allowing them to produce water up to a maximum of 60 °C and to the advanced adjustment logics provided by the electronic control, they are able to ensure not only winter heating and summer air conditioning, but also the production of thermal energy to be used for domestic hot water production. The high efficiency values that characterize them make it possible, in many cases, to cover the share of renewable energy required by the most recent regulations on limiting energy consumption and to benefit from the tax credits offered by the legislation of many countries that are dedicated to promoting equipment that meets the highest standards.

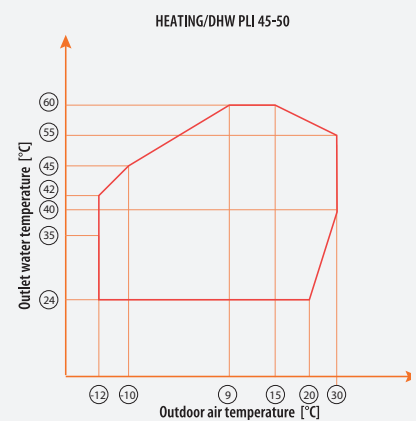
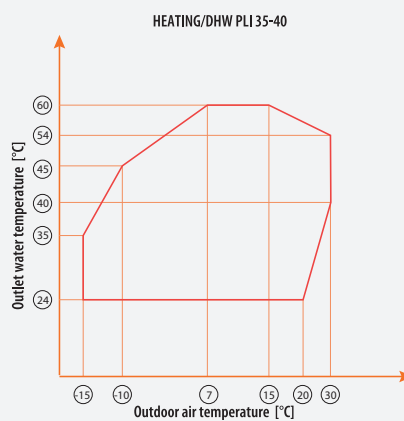
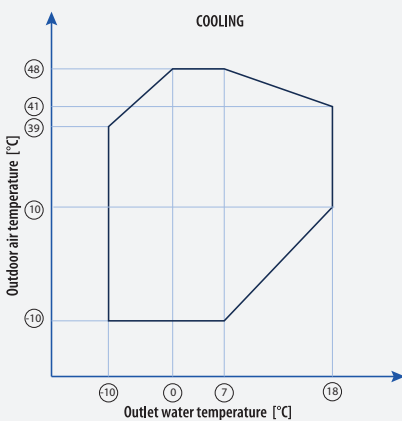

PERFORMANCE AND FUNCTIONALITY ALWAYS ON TOP

The control unit is able to activate an alternative heat generator (boiler or heating element) and employ its operation according to various user-configurable logics in unfavorable weather conditions and particularly high thermal loads, in order to integrate the missing heat capacity or to completely replace heat generation. This feature can also be used during the defrost phases, in order to balance the energy extracted from the heat transfer fluid to melt the ice present on the outside of the heat exchanger, or in the case of machine stoppage due to malfunction or maintenance.

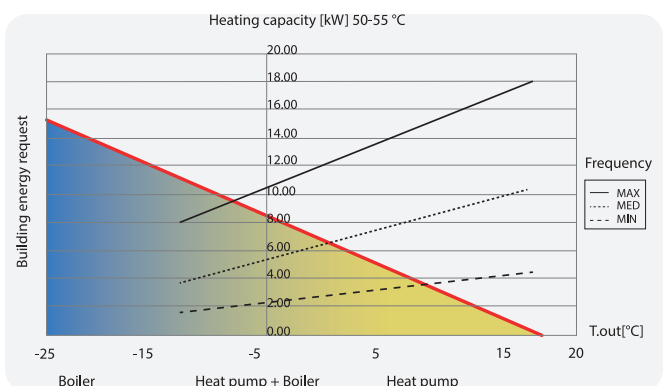

PLI C WATER CHILLERS RATED TECHNICAL DATA

PLI			035	040	045	050
Power supply		V-ph-Hz	400-3N-50			
Cooling capacity	(1)(E)	kW	36,6	43,1	48,4	53,4
Total power input	(1)(E)	kW	12,3	14,3	15,6	17,8
EER	(1)(E)		2,98	3,01	3,11	3,00
SEER	(2)(E)		5,04	5,17	5,28	5,21
Water flow	(1)	l/h	6308	7427	8334	9190
Water pressure drop	(1)(E)	kPa	28	35	43	39
Available pressure head - LP pumps	(1)	kPa	124	102	78	63
Available pressure head - HP pumps	(1)	kPa	211	187	161	144
Compressors / circuits			1/1			
Maximum current absorption		A	44,0	46,0	49,0	50,0
Start up current		A	60	60	60	60
Buffer tank volume		dm ³	125	125	125	125
Sound power level	(3)(E)	dB(A)	82	84	84	85
Sound power level, low-noise version	(3)	dB(A)	79	81	81	82
Weight without options		kg	405	409	433	434
Maximum transport weight		kg	462	467	486	488

(1) Outdoor air temperature 35°C, water temperature 12°C / 7°C (EN14511:2022)

(2) η efficiency values for heating and cooling are respectively calculated by the following formulas: $[\eta = SCOP / 2,5 - F(1) - F(2)]$ e $[\eta = SEER / 2,5 - F(1) - F(2)]$. For further information, please refer to the technical document "ErP 2009/125/EC DIRECTIVE" in the catalogue introducing pages, or to the EN14825:2022 regulation.

(3) Sound power level measured according to ISO 9614

(E) EUROVENT certified data

PLI H HEAT PUMPS RATED TECHNICAL DATA

PLI			035	040	045	050
Power supply		V-ph-Hz	400-3N-50			
Cooling capacity	(1)(E)	kW	33,6	39,7	44,9	49,1
Total power input	(1)(E)	kW	13,0	15,3	16,3	18,8
EER	(1)(E)		2,58	2,59	2,75	2,61
SEER	(2)(E)		4,12	4,40	4,57	4,56
Water flow	(1)	l/h	5784	6829	7737	8451
Water pressure drop	(1)(E)	kPa	24	30	52,9	33
Available pressure head - LP pumps	(1)	kPa	127	112	65	65
Available pressure head - HP pumps	(1)	kPa	213	198	148	147
Heating capacity	(3)(E)	kW	34,7	43,3	45,9	52,3
Total power input	(3)(E)	kW	11,7	13,9	14,4	16,6
COP	(3)(E)		2,95	3,12	3,19	3,15
SCOP	(4)(E)		3,40	3,82	3,99	4,07
Heating energy efficiency class	(5)(E)		A+	A++	A++	A++
Water flow	(3)	l/h	6013	7511	7959	9071
Water pressure drop	(3)(E)	kPa	30	34	50,7	36
Available pressure head - LP pumps	(3)	kPa	108	92	51	44
Available pressure head - HP pumps	(3)	kPa	192	175	131	124
Maximum current absorption		A	44,0	46,0	49,0	50,0
Start up current		A	60	60	60	60
Compressors / circuits			1/1			
Buffer tank volume		dm ³	125	125	125	125
Sound power level	(6)(E)	dB(A)	82	84	84	85
Sound power level, low-noise version	(6)	dB(A)	79	81	81	82
Weight without options		kg	407	413	438	438
Maximum transport weight		kg	465	470	490	492

(1) Outdoor air temperature 35°C, water temperature 12°C / 7°C (EN14511:2022)

(2) η efficiency values for heating and cooling are respectively calculated by the following formulas: $[\eta = SCOP / 2,5 - F(1) - F(2)]$ e $[\eta = SEER / 2,5 - F(1) - F(2)]$. For further information, please refer to the technical document "ErP 2009/125/EC DIRECTIVE" in the catalogue introducing pages, or to the EN14825:2022 regulation.

(3) Outdoor air temperature dry bulb 7°C / wet bulb 6°C, water temperature 40°C / 45°C (EN14511:2022)

(4) η efficiency values for heating and cooling are respectively calculated by the following formulas: $[\eta = SCOP / 2,5 - F(1) - F(2)]$ e $[\eta = SEER / 2,5 - F(1) - F(2)]$. For further information, please refer to the technical document "ErP 2009/125/EC DIRECTIVE" in the catalogue introducing pages, or to the EN14825:2022 regulation. Low temperature conditions.

(5) Seasonal energy efficiency class for LOW TEMPERATURE room heating under AVERAGE climatic conditions [EUROPEAN REGULATION No 811/2013. The energy efficiency class of this product is included in the range A+++ → D]

(6) Sound power level measured according to ISO 9614

(E) EUROVENT certified data

PLI Inverter Chillers and HP with Low GWP refrigerant

DIMENSIONAL DRAWINGS

PLI035

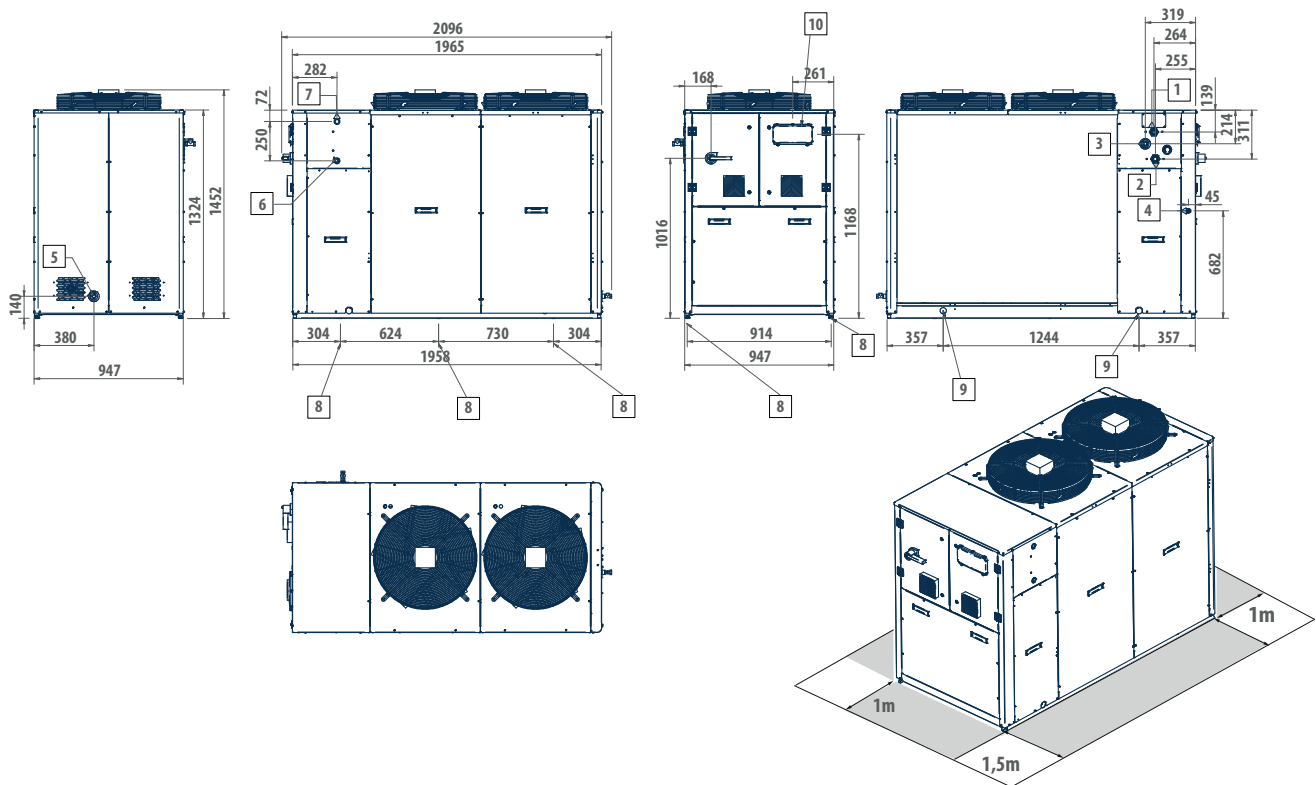

LEGEND

1	Water inlet 1 1/4 " F
2	Water outlet 1 1/4 " F
3	Water supply 1/2 " M (optional tap)
4	Power supply
5	Water drainage tank 1/2 " F
6	Heat exchanger inlet 1 " M
7	Heat exchanger outlet 1 " M
8	Vibration dumpers
9	Lifting points
10	User interface

DIMENSIONAL DRAWINGS

PLI 040 - 045 - 050

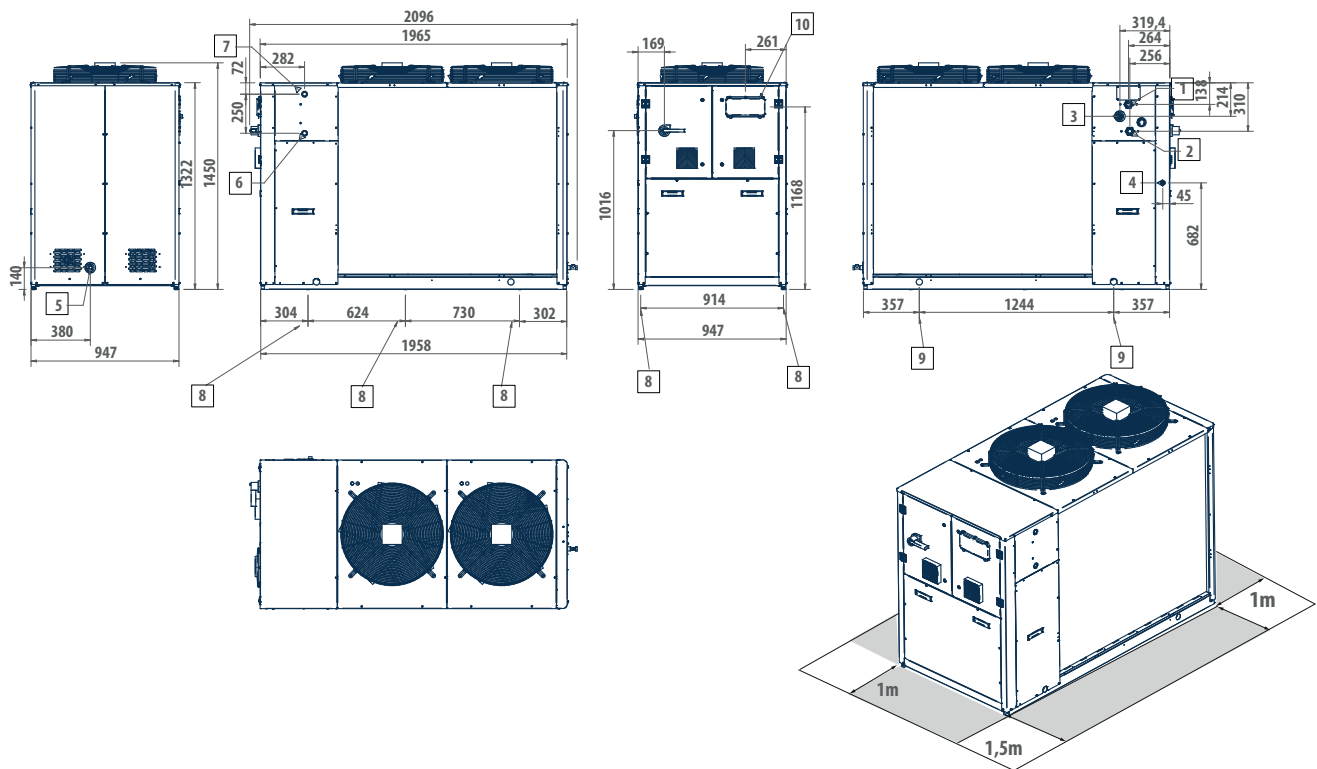

LEGEND

1	Water inlet 1 1/4" F
2	Water outlet 1 1/4" F
3	Water supply 1/2" M (optional tap)
4	Power supply
5	Water drainage tank 1/2" F
6	Heat exchanger inlet 1" M
7	Heat exchanger outlet 1" M
8	Vibration dumpers
9	Lifting points
10	User interface

Outdoor packaged unit

PLE 50 - 160 kW

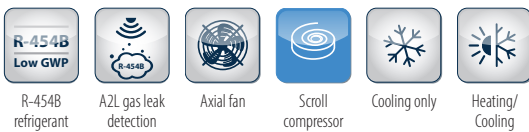

PLUS

- » Refrigerant R454B (GWP=467)
- » High seasonal efficiency values (ErP 2021 compliant)
- » Electronic expansion valve as standard
- » High configurability and wide availability of accessories
- » Availability of standard acoustic execution or in silenced configuration
- » Production of water from -10°C to 55°C
- » Operation limit extension in heating mode due to low T air option
- » Extremely compact dimensions (up to 38 kW/m²)

Air-water unit with high seasonal efficiency and low-GWP refrigerant

PLE is Galletti's new range of air-cooled packaged chillers and heat pumps for outdoor installation featuring R454B refrigerant. R454B is a next generation A2L refrigerant with a GWP of only 467, one of the lowest on the market. This GWP value ensures that the PLE range complies with the gradual reduction of greenhouse gas emissions required by the F-GAS regulation, down to the stricter limits foreseen for 2030.

The range consists of 10 models with cooling capacities from 50 to 160 kW, available as cooling only and reversible heat pump mode.

The range's main strength is its high seasonal efficiency, which is designed to permanently reduce annual energy consumption as well as meet the minimum efficiency requirements established by ErP 2021.

In order to increase the efficiency at partial loads, PLE models are provided with tandem or trio solutions (2 compressors on a single circuit) and equipped with electronic expansion valve as standard.

The use of top quality components at the cutting edge of technology in the cooling, hydraulic, and electrical systems makes PLE chillers state of the art in terms of efficiency, reliability, and operating limits. In fact, the ability to produce water from -10°C to 55°C, and full load operation with external air from -12°C to 46°C.

The range allows high configurability from an acoustic point of view, having a wide range of accessories designed to reduce noise emissions. The advanced control, always present in the whole range, allows a continuous monitoring of the operating parameters, advanced adjustment logics, and connectivity.

PLE heat pumps and water chillers are designed for heating or cooling the water to be used in air-conditioning systems for residential, commercial, or industrial use.

The use of low-GWP refrigerant ensures compliance with the limits established by the F-GAS regulation regarding gases that potentially contribute to global warming (greenhouse gases).

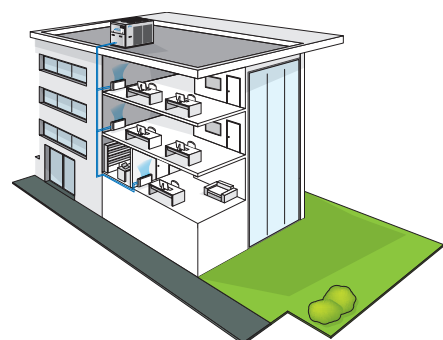

MAIN COMPONENTS

Very low GWP refrigerant

Use of R454B refrigerant with low environmental impact. R454B is a next-generation A2L refrigerant with a GWP of only 467, one of the lowest on the market. This GWP value ensures that the PLE range complies with the gradual reduction of quotas of greenhouse refrigerants in the European market required by the F-GAS regulation, down to the stricter limits foreseen for 2030

Scroll compressors

The scroll-type compressors designed to work with R454B, which can be sound insulated, include internal thermal protection of the windings and are installed on special anti-vibration supports. The scroll-type compressors are equipped with an IDV valve. The IDV intermediate delivery valve technology allows the compressor to avoid losses caused by overcompression and, consequently, the additional work the motor has to perform in partial-load operation, thus saving energy and improving seasonal and partial-load efficiency from 3% to 10%.

Microchannel

The entire Chiller range has microchannel coils as a standard feature. The large heat exchange surface, the absence of a copper-aluminum interface, and the perfect flow of air make it possible to achieve the same performance while reducing the refrigerant charge by up to 40%, with obvious benefits from an ecological point of view. Microchannel coils Galletti always feature surface treatment as a standard feature in order to provide maximum safety, even in harsh environments.

Electronic valve

It is standard on the entire range and offers greater responsiveness during transients. The electronics also manage the synergistic operation of the compressors and the valve, thereby making it possible to vary overheating and maximize efficiency at partial loads.



CONFIGURATOR

The models are completely configurable by selecting the version and the options. To the right is shown an example of configuration.

Version	Field	1	2	3	4	5	6	7	8	9	10	11	12	13
PLE162HS0B		A	1	S	0	E	0	0	2	0	0	G	0	1

To verify the compatibility of the options, use the selection software or the price list.

AVAILABLE VERSIONS

Only cooling versions

- PLE..CS0B Power supply 400V-3N-50Hz
- PLE..CS2B Power supply 400V-3N-50Hz + circuit breaker
- PLE..CS4B Power supply 400V-3-50Hz
- PLE..CS5B Power supply 400V-3-50Hz + circuit breaker

Reversible heat pump versions

- PLE..HS0B Power supply 400V-3N-50Hz
- PLE..HS2B Power supply 400V-3N-50Hz + circuit breaker
- PLE..HS4B Power supply 400V-3-50Hz
- PLE..HS5B Power supply 400V-3-50Hz + circuit breaker

CONFIGURATION OPTIONS

- | | |
|--|--|
| <p>1 Expansion valve</p> <ul style="list-style-type: none"> A Electronic <p>2 Water pump and accessories</p> <ul style="list-style-type: none"> 0 Absent 1 LP pump + expansion vessel 2 LP run and standby double pump + expansion vessel 3 HP pump + expansion vessel 4 HP run and standby double pump + expansion vessel A LP inverter pump + expansion vessel B LP run and standby double inverter pump + expansion vessel C HP inverter pump + expansion vessel D HP run and standby double inverter pump + expansion vessel <p>3 Water buffer tank</p> <ul style="list-style-type: none"> 0 Absent S Selected <p>4 Partial heat recovery</p> <ul style="list-style-type: none"> 0 Absent D Desuperheater with water pump free contact <p>5 Air flow modulation</p> <ul style="list-style-type: none"> A Condensation control with high-head EC electronically controlled fans C Condensation control by phase-cut fans E Condensing control with electronic EC fans <p>6 Antifreezing kit</p> <ul style="list-style-type: none"> 0 Absent E Evaporator P Evaporator and water pump S Evaporator, water pump and water buffer tank <p>7 Acoustic insulation and attenuation</p> <ul style="list-style-type: none"> 0 Absent | <ul style="list-style-type: none"> 3 Compressor soundproof insulations and compressor compartment acoustic insulation <p>8 Refrigerant pipework accessories</p> <ul style="list-style-type: none"> 0 Absent 2 Operation limit extension low T air (Liquid separator in compressor intake + liquid injection) <p>9 Remote control / Serial communication</p> <ul style="list-style-type: none"> 0 Absent 2 RS485 serial board (Carel / Modbus protocol) B BACNET IP / PCOWEB serial board (advanced controller required) G BACNET IP / PCOWEB + SUPERVISOR SOFTWARE (GWeb) S Remote simplified user panel X Remote user panel for advanced controller <p>10 Special coils / Protective treatments</p> <ul style="list-style-type: none"> 0 Copper-aluminum (standard heat pump only) C Cataphoresis treatment on fins and coil carpentry E Microchannel in Long Life Alloy (standard for chiller) I Hydrophilic M Microchannels coil with e-coating treatment P Pre-painted fins with polyester paint R Copper-copper <p>11 Anti vibration shock mounts</p> <ul style="list-style-type: none"> 0 Absent G Rubber anti vibration shock mounts M Spring anti vibration shock mounts <p>12 Outdoor coil trace heater</p> <ul style="list-style-type: none"> 0 Absent 1 Selected <p>13 Onboard controller</p> <ul style="list-style-type: none"> 1 Advanced |
|--|--|

ACCESSORIES

A	Outdoor finned coil heat exchanger protection filters	M	0-10 V signal for external user pump control (on-board pump excluded)
B	Outdoor finned coil heat exchanger protection grille	N	Compressor tandem/trio isolation valves
C	Pair of couplings Victaulic	O	Night-time low-noise
D	ON/OFF status of the compressors	Q	Temperature probe for pump shutdown on the primary circuit
E	Remote control for step capacity limit (advanced controller required)	R	Enabling 2nd set-point / external alarm signaling via digital input
F	Configurable digital alarm board (advanced controller required)	S	Hot-wire electronic flow switch
G	Soft starter	T	Mains power analyzer for monitoring and reducing power consumption
H	Power factor capacitors	U	Unit lifting pipes
I	Refrigerant sensors	V	Set-point modification with 4-20mA signal
L	Water pipes additional insulation		

PLE Chillers and HP with Low GWP refrigerant

WATER CHILLERS RATED TECHNICAL DATA PLE C

PLE			052	062	072	082	092
Power supply		V-ph-Hz	400 / 3+N / 50				
Cooling capacity	(1)(E)	kW	53,0	59,0	66,0	72,0	88,0
Total power input	(1)(E)	kW	17,4	20,1	23,0	26,3	30,2
EER	(1)(E)		3,03	2,92	2,87	2,73	2,91
SEER	(2)(E)		4,42	4,23	4,15	4,12	4,45
Water flow	(1)	l/h	9069	10116	11365	12318	15112
Water pressure drop	(1)(E)	kPa	22	27	27	31	33
Available pressure head - LP pumps	(1)	kPa	164	155	150	140	124
Available pressure head - HP pumps	(1)	kPa	213	204	198	188	183
Maximum current absorption		A	48,0	52,0	58,0	64,0	78,0
Start up current		A	163	170	184	224	254
Startup current with soft starter		A	128	133	144	174	200
Compressors / circuits			2/1				
Buffer tank volume		dm ³	125	125	125	125	190
Sound power level	(3)(E)	dB(A)	80	81	81	81	84
Sound power level, low-noise version	(3)	dB(A)	77	78	78	78	81
Weight without options		kg	462	465	469	476	590
Maximum transport weight		kg	520	523	529	536	682

PLE			102	122	132	142	152
Power supply		V-ph-Hz	400 / 3+N / 50				
Cooling capacity	(1)(E)	kW	97,0	108	122	135	145
Total power input	(1)(E)	kW	34,3	39,9	42,2	49,0	56,1
EER	(1)(E)		2,82	2,72	2,89	2,74	2,59
SEER	(2)(E)		4,25	4,26	4,25	4,18	4,11
Water flow	(1)	l/h	16625	18648	20981	23169	25009
Water pressure drop	(1)(E)	kPa	39	35	43	44	50
Available pressure head - LP pumps	(1)	kPa	115	115	156	148	135
Available pressure head - HP pumps	(1)	kPa	173	174	177	170	157
Maximum current absorption		A	85,0	94,0	105	116	127
Start up current		A	304	304	308	376	376
Startup current with soft starter		A	239	239	243	296	296
Compressors / circuits			2/1				
Buffer tank volume		dm ³	190	190	295	295	295
Sound power level	(3)(E)	dB(A)	84	85	88	88	89
Sound power level, low-noise version	(3)	dB(A)	81	82	85	85	87
Weight without options		kg	591	642	750	808	858
Maximum transport weight		kg	683	733	906	962	1012

(1) Outdoor air temperature 35°C, water temperature 12°C / 7°C (EN14511:2022)

(2) η efficiency values for heating and cooling are respectively calculated by the following formulas: $[\eta = SCOP / 2,5 - F(1) - F(2)]$ e $[\eta = SEER / 2,5 - F(1) - F(2)]$. For further information, please refer to the technical document "ErP 2009/125/EC DIRECTIVE" in the catalogue introducing pages, or to the EN14825:2022 regulation.

(3) Sound power level measured according to ISO 9614

HEAT PUMPS RATED TECHNICAL DATA PLE H

PLE			052	062	072	082	092
Power supply		V-ph-Hz	400 / 3+N / 50				
Cooling capacity	(1)(E)	kW	50,1	54,9	62,5	70,5	83,8
Total power input	(1)(E)	kW	18,5	21,3	24,0	27,0	30,8
EER	(1)(E)		2,71	2,58	2,60	2,61	2,72
SEER	(2)(E)		4,40	4,21	4,11	3,93	4,40
Water flow	(1)	l/h	8624	9446	10758	12140	14418
Water pressure drop	(1)(E)	kPa	21	24	25	31	28
Available pressure head - LP pumps	(1)	kPa	168	160	151	138	129
Available pressure head - HP pumps	(1)	kPa	218	210	200	186	187
Heating capacity	(3)(E)	kW	59,0	66,0	75,0	84,0	99,0
Total power input	(3)(E)	kW	18,3	20,6	23,5	26,0	30,7
COP	(3)(E)		3,21	3,20	3,20	3,24	3,23
SCOP	(2)(E)		3,61	3,66	3,77	3,90	3,61
Heating energy efficiency class	(4)(E)		A+				
Water flow	(3)	l/h	10193	11420	13026	14577	17208
Water pressure drop	(3)(E)	kPa	28	34	35	43	36
Available pressure head - LP pumps	(3)	kPa	160	150	138	118	119
Available pressure head - HP pumps	(3)	kPa	209	199	185	164	177
Maximum current absorption		A	48,0	52,0	58,0	64,0	78,0
Start up current		A	163	170	184	224	254
Startup current with soft starter		A	128	133	144	174	200
Compressors / circuits			2/1				
Buffer tank volume		dm ³	125	125	125	125	190
Sound power level	(5)(E)	dB(A)	80	81	81	81	84
Sound power level, low-noise version	(5)	dB(A)	77	78	78	78	81
Weight without options		kg	502	505	517	532	646
Maximum transport weight		kg	560	563	577	592	739

PLE			102	122	132	142	152
Power supply		V-ph-Hz	400 / 3+N / 50				
Cooling capacity	(1)(E)	kW	92,5	107	120	132	142
Total power input	(1)(E)	kW	36,1	41,0	44,8	49,7	56,3
EER	(1)(E)		2,56	2,61	2,68	2,66	2,53
SEER	(2)(E)		4,02	4,22	4,23	4,15	3,93
Water flow	(1)	l/h	15927	18419	20699	22745	24516
Water pressure drop	(1)(E)	kPa	36	34	42	38	44
Available pressure head - LP pumps	(1)	kPa	116	115	158	156	138
Available pressure head - HP pumps	(1)	kPa	175	173	179	177	160
Heating capacity	(3)(E)	kW	111	125	138	157	172
Total power input	(3)(E)	kW	34,7	39,1	43,1	48,4	53,8
COP	(3)(E)		3,20	3,20	3,21	3,24	3,20
SCOP	(2)(E)		3,61	3,84	3,73	3,79	3,73
Heating energy efficiency class	(4)(E)		A+				
Water flow	(3)	l/h	19221	21658	23996	27204	29845
Water pressure drop	(3)(E)	kPa	51	46	55	51	60
Available pressure head - LP pumps	(3)	kPa	101	96	140	136	111
Available pressure head - HP pumps	(3)	kPa	159	154	162	158	132
Maximum current absorption		A	85,0	94,0	105	116	127
Start up current		A	304	304	308	376	376
Startup current with soft starter		A	239	239	243	296	296
Compressors / circuits			2/1				
Buffer tank volume		dm ³	190	190	295	295	295
Sound power level	(5)(E)	dB(A)	84	85	88	88	89
Sound power level, low-noise version	(5)	dB(A)	81	82	85	85	87
Weight without options		kg	647	711	828	906	956
Maximum transport weight		kg	739	801	983	1059	1109

(1) Outdoor air temperature 35°C, water temperature 12°C / 7°C (EN14511:2022)

(2) η efficiency values for heating and cooling are respectively calculated by the following formulas: [$\eta = SCOP / 2,5 - F(1) - F(2)$] e [$\eta = SEER / 2,5 - F(1) - F(2)$]. For further information, please refer to the technical document "Erp 2009/125/EC DIRECTIVE" in the catalogue introducing pages, or to the EN14825:2022 regulation.

(3) Outdoor air temperature dry bulb 7°C / wet bulb 6°C, water temperature 40°C / 45°C (EN14511:2022)

(4) Seasonal energy efficiency class for LOW TEMPERATURE room heating under AVERAGE climatic conditions [EUROPEAN REGULATION No 811/2013. The energy efficiency class of this product is included in the range A+++ → D]

(5) Sound power level measured according to ISO 9614

(E) EUROVENT certified data

PLE Chillers and HP with Low GWP refrigerant

DIMENSIONAL DRAWINGS

PLE 52-82

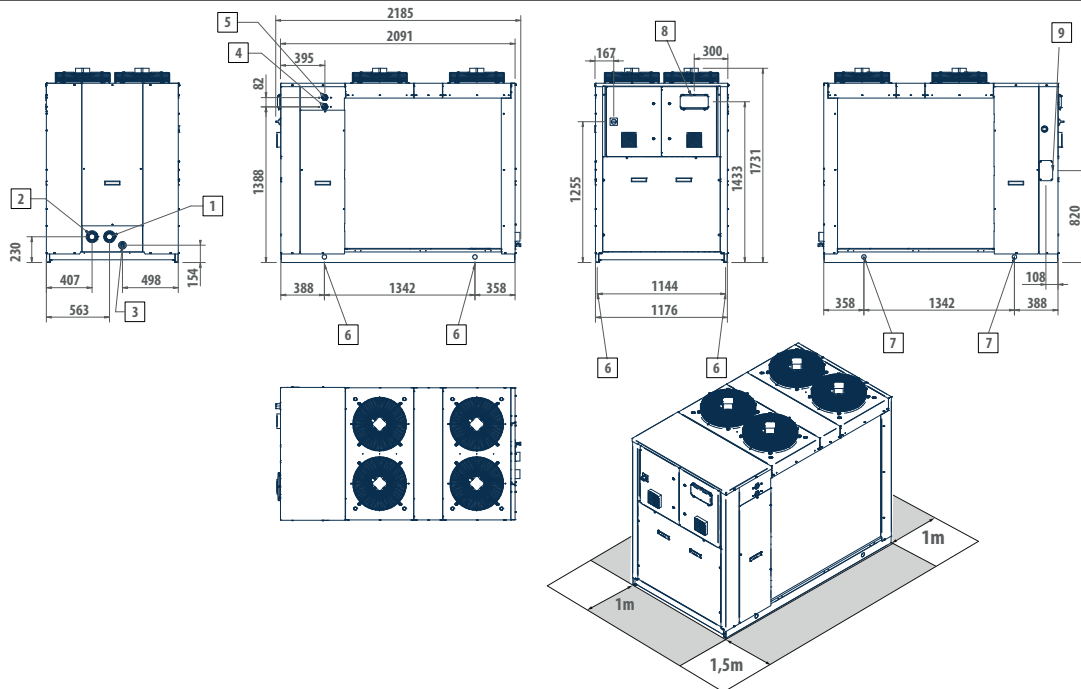

LEGEND

1	Water inlet Victaulic 2"	6	Vibration dampers
2	Water outlet Victaulic 2"	7	Lifting points
3	Water drainage 1/2" F	8	User interface
4	Heat exchanger inlet 1" 1/4 F	9	Power supply input
5	Heat exchanger outlet 1" 1/4 F		

PLE 92-122

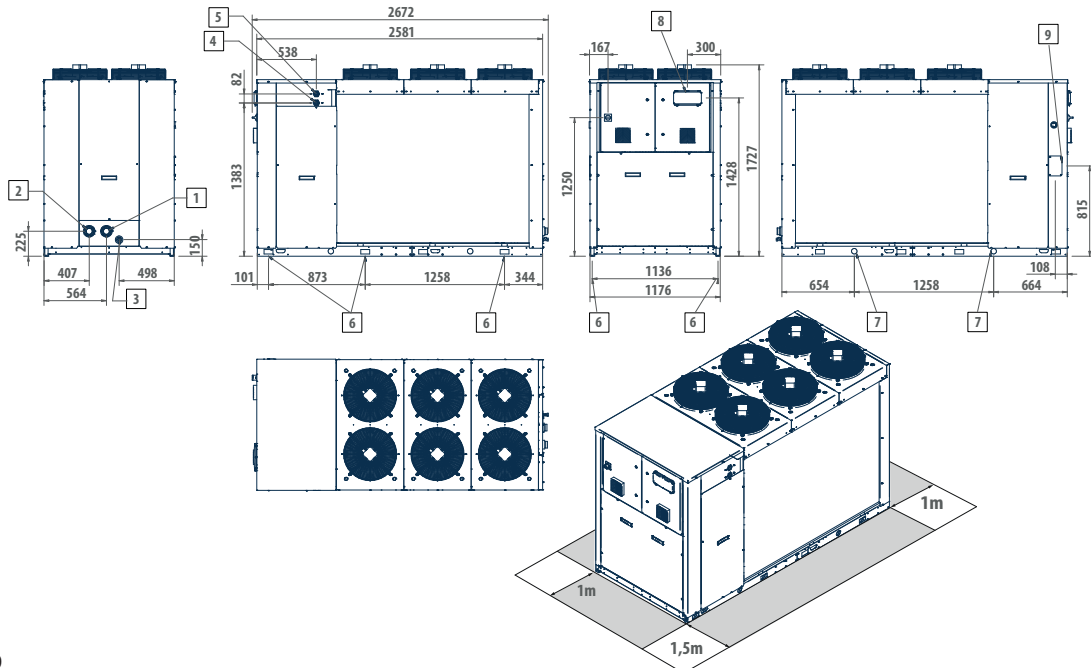

LEGEND

1	Water inlet Victaulic 2"	6	Vibration dampers
2	Water outlet Victaulic 2"	7	Lifting points
3	Water drainage 1/2" F	8	User interface
4	Heat exchanger inlet 1" 1/4 F	9	Power supply input
5	Heat exchanger outlet 1" 1/4 F		

DIMENSIONAL DRAWINGS

PLE 132-152

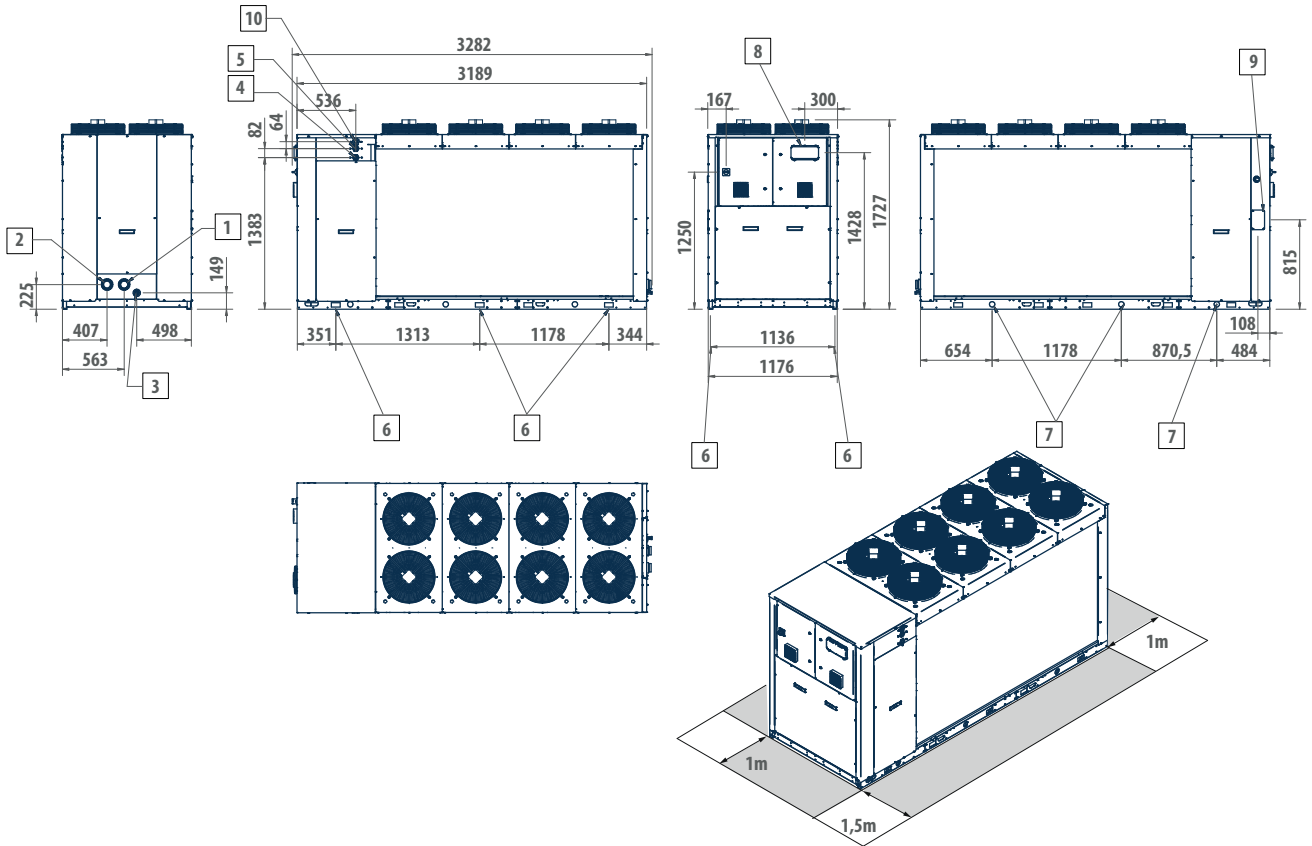

LEGEND

1	Water inlet Victaulic 2" 1/2
2	Water outlet Victaulic 2" 1/2
3	Water drainage 1/2" F
4	Heat exchanger inlet 1" 1/4 F
5	Heat exchanger outlet 1" 1/4 F
6	Vibration dumpers
7	Lifting points
8	User interface
9	Power supply input
10	Outlet safety valve 1" 1/4 NPT



Outdoor packaged unit with R290

PLN 50 - 150 kW



Scroll compressor



R-290 Refrigerant



A3 gas leak detection



3-way external valve management



Cooling only



Heating/ Cooling

Air-water units with R290 refrigerant and multi-scroll compressors

The reduction of polluting emissions, whether directly related to the use of greenhouse gases or more indirectly related to emissions from the production of electricity used during the lifetime of a heat pump, is the first and most important pillar on which Galletti has based its Advanced Design solutions.

This journey has led to the creation of PLN, a new range of air-water units with natural refrigerant and multi-scroll solutions. Their extremely wide operating range and high performance under all operating conditions make them the perfect answer to the need to gradually phase out the use of energy from fossil sources for heating and cooling buildings.

Thanks to the high temperature of the water produced (up to 75°C), we can replace a fossil fuel generator while maintaining the full performance of the existing emissions system.

By leveraging multi-scroll configurations (with up to 4 compressors), we produce exactly what is needed at any given moment to ensure people's comfort no more, no less while working to maximize the overall system efficiency.

We look to the future of our environment as well as the needs of the people who use our products.

We work every day to make indoor comfort more sustainable.

PLUS

- » R290 refrigerant (GWP=3)
- » Multi-scroll solutions
- » Low refrigerant charge (<10 kg for circuit)
- » Production of hot water up to 75°C
- » Full load operation down to -20°C air (45°C water)
- » Very high seasonal efficiency values
- » Power output and COP monitoring (option)
- » Availability of silenced setups

PLN heat pumps and water chillers are designed for heating or cooling the water to be used in air-conditioning systems for residential, commercial or industrial use.

The use of the natural refrigerant R290 (propane) ensures compliance with the more stringent limits imposed by the F-GAS regulation regarding gases with a potential contribution to global warming (greenhouse gases).

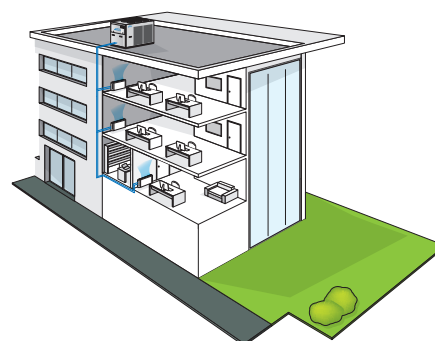

Natural refrigerant (R290)

R290 (propane) is a natural refrigerant with a GWP (Global Warming Potential) of only 3. This makes it a strong contender to be one of the leading refrigerants for air conditioning solutions. It has a much lower contribution to the greenhouse effect than synthetic refrigerants and physical properties that make it ideal for the design requirements associated with the ever-increasing use of heat pumps.

Scroll compressor

The new scroll compressor for R290 is designed for both single and parallel configurations, offering higher efficiency and extended durability. Featuring innovative elements such as intermediate discharge valves (IDV) for superior seasonal efficiency, lead-free polymer bearings for improved performance under low-lubrication conditions, and a patented motor for optimal cooling, this series sets a new benchmark in compressor technology. In addition, the internal non-return valve (INRV) minimizes the risk of leakage, while the brazed oil tube connection ensures leak-free operation.

EXTENDED OPERATING RANGE FOR EACH APPLICATION

Extremely extended operating limits

It is now clear that heat pumps will play a fundamental role in achieving the objectives of the European Green Deal, foremost among them the phase-out of fossil fuels. One of the key requirements for a heat pump to be considered a valid alternative to boilers, even in the harshest climates, is undoubtedly the extension of the operating limits that have characterized traditional heat pumps used up to now.

Thanks to the use of next-generation scroll compressor technology, combined with the use of propane as a refrigerant and the innovative solutions developed by the Advanced Design Unit of Galletti during the design and prototyping phase, PLN ensures the ability to produce hot water at very high temperatures (up to 75°C) and to operate at full load even with extremely low outdoor temperatures (down to -20°C).

In this way (given the level of temperatures achievable, which would be unthinkable with a traditional heat pump), it is possible to envision replacing a combustion generator with an R290 heat pump, even if building insulation measures are postponed. This allows for a significant increase in the share of renewable energy used for heating, without compromising indoor comfort.

Advanced Design solutions look to the future of the environment and the needs of the people who use our products

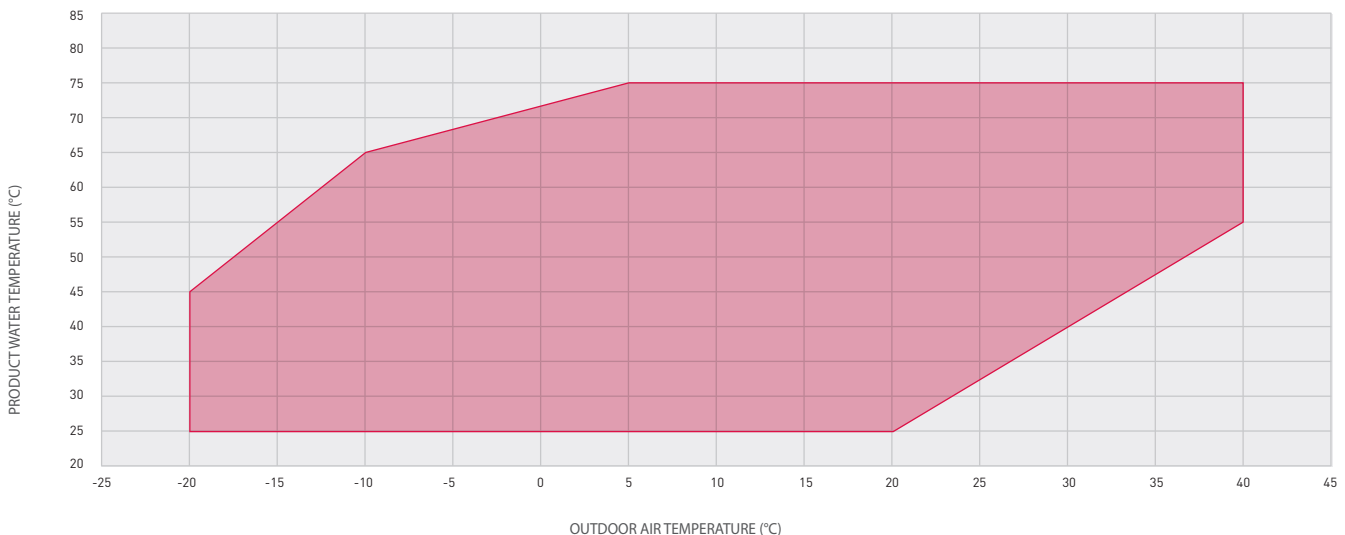

Chillers and heat pumps with natural refrigerant

CONFIGURATOR

The models are completely configurable by selecting the version and the options. To the right is shown an example of configuration.

Version	Field	1	2	3	4	5	6	7	8	9	10	11	12	13	14	15
PLN072HS2A	A	1	S	0	E	E	0	0	0	0	I	G	0	1	2	0

To verify the compatibility of the options, use the online selection software or the price list.

AVAILABLE VERSIONS

Cooling only versions

PLN..CS2A	400V-3N-50Hz power supply + circuit breakers
PLN..CS5A	400V-3-50Hz power supply + circuit breakers

Versioni pompa di calore reversibile

PLN..HS2A	400V-3N-50Hz power supply + circuit breakers
PLN..HS5A	400V-3-50Hz power supply + circuit breakers

CONFIGURATION OPTIONS

- 1 Expansion valve**
 - A Electronic valve
- 2 Water pump and accessories**
 - 0 Absent
 - 1 Single standard pump
 - 2 Double std pump - OR
 - 3 Single HP pump
 - 4 HP double pump - OR
 - A Single inverter standard pump
 - B Standard dual inverter OR pump
 - C Inverter Single HP pump
 - D Dual inverter HP OR pump
- 3 Water buffer tank**
 - 0 Absent
 - S Selected
- 4 De-superheater**
 - 0 Absent
 - D Included with pump free contact
- 5 Condensation/Evaporation Control**
 - A With EC Fans high pressure head
 - C Phase cutting (not available up to size 114)
 - E with EC Fans (supplied up to size 114)
- 6 Antifreezing kit**
 - E Only cooling versions and plate exchanger (supplied)
 - P Plate exchanger + pump
 - S Plate exchanger + pump + tank
 - T For plate exchanger and tank
- 7 Acoustic insulation and attenuation**
 - 0 Absent
 - 3 Compressor compartment acoustic insulation and sound blanket
 - 6 Compressor compartment acoustic insulation and sound blanket + Low-noise fans
- 8 Water low temperature production**
 - 0 Up to 5°C
 - 1 Up to 0°C
 - 2 Up to -5°C (only if the option 5 = E or A)
- 9 Remote control**
 - 0 Absent
 - 2 RS485 Board (Modbus protocol or Carel)
 - B BACNET IP/PCOWEB serial board
 - G BACNET IP / PCOWEB serial board + supervision software
 - S Simplified additional remote control panel
 - T Touch screen control (up to 50m)
 - X Additional remote control for advanced control (up to 50m)
- 10 Special coils / Protective treatments**
 - 0 Copper / aluminium (standard for H version)
 - C Cataphoresis (only for H versions)
 - E Microchannel in Long Life Alloy (standard for C version)
 - I Hydrophilic (only H version)

- M Microchannel with E-coating (only for C version)
- P Pre-painted fins with epoxy painting (only H version)
- R Copper-copper (heat pump only)
- 11 Base vibration dampers**
 - 0 Absent
 - G Made of rubber
 - M With spring
- 12 Outdoor coil trace heater**
 - 0 Absent
 - 1 Present (only H version)
- 13 Control panel**
 - 1 Advanced
 - 2 Advanced with touch screen display
- 14 Water flow control**
 - 2 Vane-type flow switch
 - 3 Hot-wire electronic flow switch
- 15 DHW accessory only (if option 3 = 0)**
 - 0 Absent
 - 1 DHW 3-way valve + tank probe
 - 2 DHW mode enabling with dry contact
 - 3 DHW 3-way valve (supplied) + ACS from ID contact

ACCESSORIES

B	Outdoor finned coil heat exchanger protection grille
D	ON/OFF status of the compressors (mandatory only if opt.4 = D)
E	Remote control for power step limits (accessory 2 excluded)
F	Configurable digital alarm board
G	Soft starter
H	Power factor capacitors
I	Refrigerant sensors (standard)
L	Double insulation water side (as standard for tank)
M	0-10V signal for external user pump control (only if opt 4 = 0)
N	Integration system enabling contact (boiler / electric heater) plant
O	Night-time low-noise (only if opt 7 different from 6)
Q	Temperature probe for pump shutdown on the primary circuit
R	Enabling 2nd set-point
T	Mains power analyzer for monitoring of power consumption
V	Set-point modification with 4-20mA signal
Z	Flow meter for calculating power output
1	Integration system enabling contact (electric heater) DHW (only if opt 15 different from 0)
2	Smart Grid Certification (option E excluded)
3	Deaerator for hydraulic circuit (supplied as an accessory)
4	Dirt separator (supplied as an accessory)



RATED TECHNICAL DATA OF PLN C WATER CHILLERS

PLN C			052	072	082	104	114	134	154
Power supply		V-ph-Hz	400-3N-50						
Cooling capacity	(1)(E)	kW	50,8	65,5	77,4	106	118	138	160
Total power input	(1)(E)	kW	16,5	20,1	24,3	35,6	40,6	43,3	51,7
EER	(1)(E)		3,08	3,25	3,19	2,99	2,90	3,18	3,09
SEER	(2)(E)		4,12	4,61	4,40	4,45	4,65	5,00	4,62
Water flow	(1)	l/h	8743	11262	13322	18341	20289	23702	27456
Water pressure drop	(1)(E)	kPa	25	27	35	55	65	35	44
Available pressure head - LP pumps	(1)	kPa	158	145	129	113	102	198	178
Available pressure head - HP pumps	(1)	kPa	192	180	165	172	160	322	301
Compressors / circuits			2/1	2/1	2/1	4/2	4/2	4/2	4/2
Maximum current absorption		A	67,0	77,0	84,0	129	137	152	157
Start up current		A	187	240	247	249	264	315	320
Startup current with soft starter		A	143	181	188	205	217	256	261
Buffer tank volume		dm ³	125	200	200	200	200	600	600
Sound power level	(3)(E)	dB(A)	84	85	85	85	86	87	87
Sound power level, low-noise version	(3)	dB(A)	81	82	82	82	83	84	84
Maximum transport weight		kg	1042	1270	1270	1805	1805	2587	2589

(1) Outdoor air temperature 35°C, water temperature 12°C / 7°C (EN14511:2022)

(2) η efficiency values for heating and cooling are respectively calculated by the following formulas: $[\eta = SCOP / 2,5 - F(1) - F(2)]$ e $[\eta = SEER / 2,5 - F(1) - F(2)]$. For further information, please refer to the technical document "ErP 2009/125/EC DIRECTIVE" in the catalogue introducing pages, or to the EN14825:2022 regulation.

(3) Sound power level measured according to ISO 9614

(E) EUROVENT certified data

Chillers and heat pumps with natural refrigerant

RATED TECHNICAL DATA PLN H HEAT PUMPS

PLN H			052	072	082	104	114	134	154
Power supply		V-ph-Hz	400 / 3+N / 50						
Cooling capacity	(1)(E)	kW	48,6	63,4	72,0	101	111	130	148
Total power input	(1)(E)	kW	16,9	21,2	25,2	35,3	39,2	41,6	49,9
EER	(1)(E)		2,88	2,99	2,86	2,86	2,83	3,12	2,97
SEER	(2)(E)		4,02	4,32	4,11	4,28	4,50	4,90	4,55
Water flow	(1)	l/h	8355	10912	12397	17374	19097	22336	25465
Water pressure drop	(1)(E)	kPa	25	30	37	49	57	32	38
Available pressure head - LP pumps	(1)	kPa	158	144	128	116	104	199	180
Available pressure head - HP pumps	(1)	kPa	192	179	163	175	162	322	303
Heating capacity	(3)(E)	kW	54,6	68,6	79,5	106	120	132	154
Total power input	(3)(E)	kW	16,7	20,7	23,9	32,8	36,6	40,0	47,7
COP	(3)(E)		3,28	3,32	3,32	3,24	3,29	3,30	3,22
SCOP	(4)(E)		3,80	3,70	3,82	3,90	4,00	3,80	3,95
SCOP	(5)(E)		3,05	3,03	3,12	3,30	3,34	3,14	3,25
Heating energy efficiency class	(6)(E)		A+	A+	A+	A++	A++	A+	A++
Heating energy efficiency class	(7)(E)		A+	A+	A+	A++	A++	A+	A++
Water flow	(3)	l/h	9464	11898	13782	18364	20827	22910	26629
Water pressure drop	(3)(E)	kPa	29	33	42	49	59	32	40
Available pressure head - LP pumps	(3)	kPa	149	136	114	101	86	179	151
Available pressure head - HP pumps	(3)	kPa	183	171	149	159	144	301	272
Maximum current absorption		A	67,0	77,0	84,0	129	137	152	157
Startup current		A	187	240	247	249	264	315	320
Startup current with soft starter		A	143	181	188	205	217	256	261
Compressors / circuits			2/1	2/1	2/1	4/2	4/2	4/2	4/2
Buffer tank volume		dm ³	125	200	200	200	200	600	600
Sound power level	(8)(E)	dB(A)	84	85	85	85	86	87	87
Sound power level, low-noise version	(8)	dB(A)	81	82	82	82	83	84	84
Maximum transport weight		kg	960	1196	1206	1698	1771	2534	2624

(1) Outdoor air temperature 35°C, water temperature 12°C / 7°C (EN14511:2022)

(2) η efficiency values for heating and cooling are respectively calculated by the following formulas: $[\eta = SCOP / 2,5 - F(1) - F(2)]$ e $[\eta = SEER / 2,5 - F(1) - F(2)]$. For further information, please refer to the technical document "ErP 2009/125/EC DIRECTIVE" in the catalogue introducing pages, or to the EN14825:2022 regulation.

(3) Outdoor air temperature dry bulb 7°C / wet bulb 6°C, water temperature 40°C / 45°C (EN14511:2022)

(4) η efficiency values for heating and cooling are respectively calculated by the following formulas: $[\eta = SCOP / 2,5 - F(1) - F(2)]$ e $[\eta = SEER / 2,5 - F(1) - F(2)]$. For further information, please refer to the technical document "ErP 2009/125/EC DIRECTIVE" in the catalogue introducing pages, or to the EN14825:2022 regulation. Low temperature conditions.

(5) η efficiency values for heating and cooling are respectively calculated by the following formulas: $[\eta = SCOP / 2,5 - F(1) - F(2)]$ e $[\eta = SEER / 2,5 - F(1) - F(2)]$. For further information, please refer to the technical document "ErP 2009/125/EC DIRECTIVE" in the catalogue introducing pages, or to the EN14825:2022 regulation. Medium temperature conditions.

(6) Seasonal energy efficiency class for LOW TEMPERATURE room heating under AVERAGE climatic conditions [EUROPEAN REGULATION No 811/2013]

(7) Seasonal energy efficiency class for MEDIUM TEMPERATURE room heating under AVERAGE climatic conditions [EUROPEAN REGULATION No 811/2013]

(8) Sound power level measured according to ISO 9614

(E) EUROVENT certified data

DIMENSIONAL DRAWINGS

PLN 52

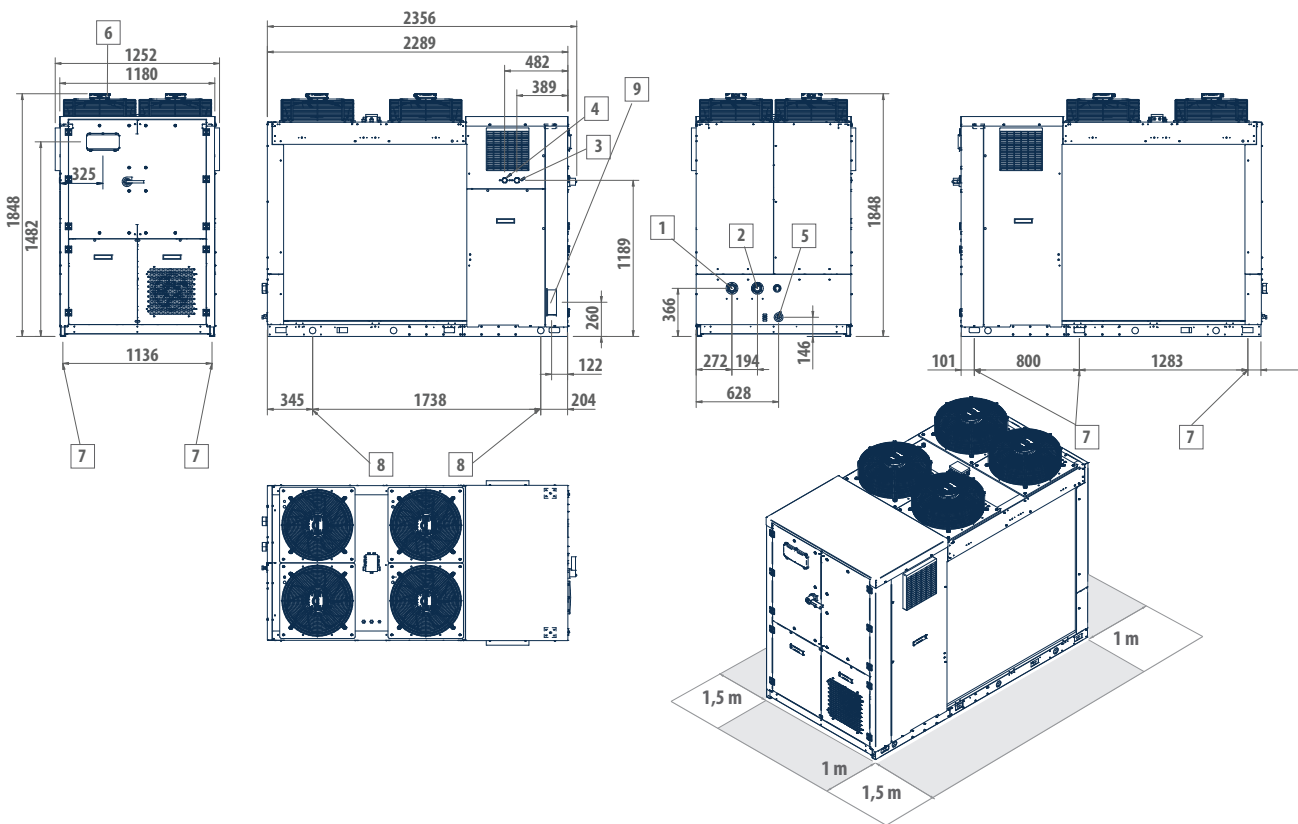

LEGEND

1	Water inlet on user side 2" F
2	Water outlet user 2" F
3	Desuperheater water inlet 1" F
4	De-superheater water outlet 1" F
5	Water drainage 1/2" F
6	User interface
7	Vibration dampers
8	Lifting points
9	Power supply input

Chillers and heat pumps with natural refrigerant

DIMENSIONAL DRAWINGS

PLN 72 - 82

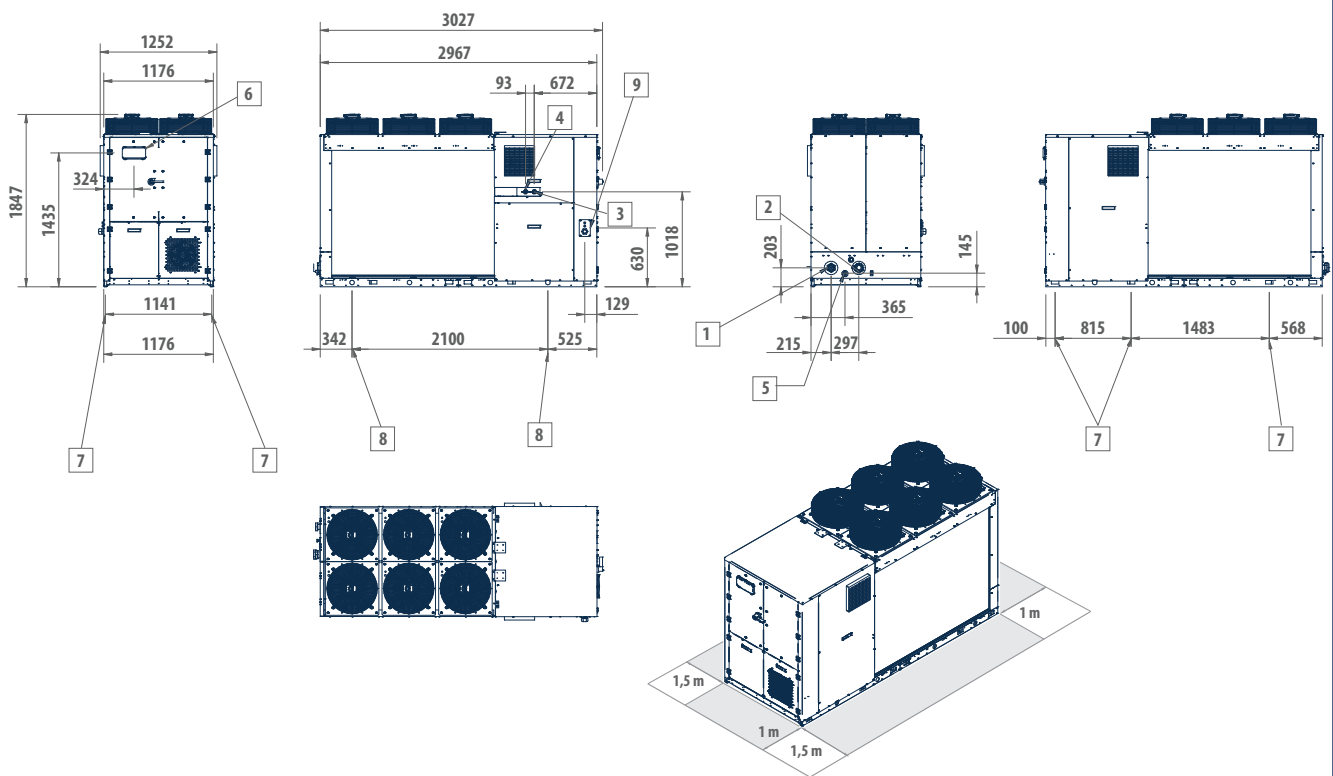

LEGEND

1	Water inlet on user side 2" 1/2 F
2	Water outlet user 2" 1/2 F
3	Desuperheater water inlet 1" F
4	De-superheater water outlet 1" F
5	Water drainage 1/2" F
6	User interface
7	Vibration dampers
8	Lifting points
9	Power supply input

DIMENSIONAL DRAWINGS

PLN 104 - 114

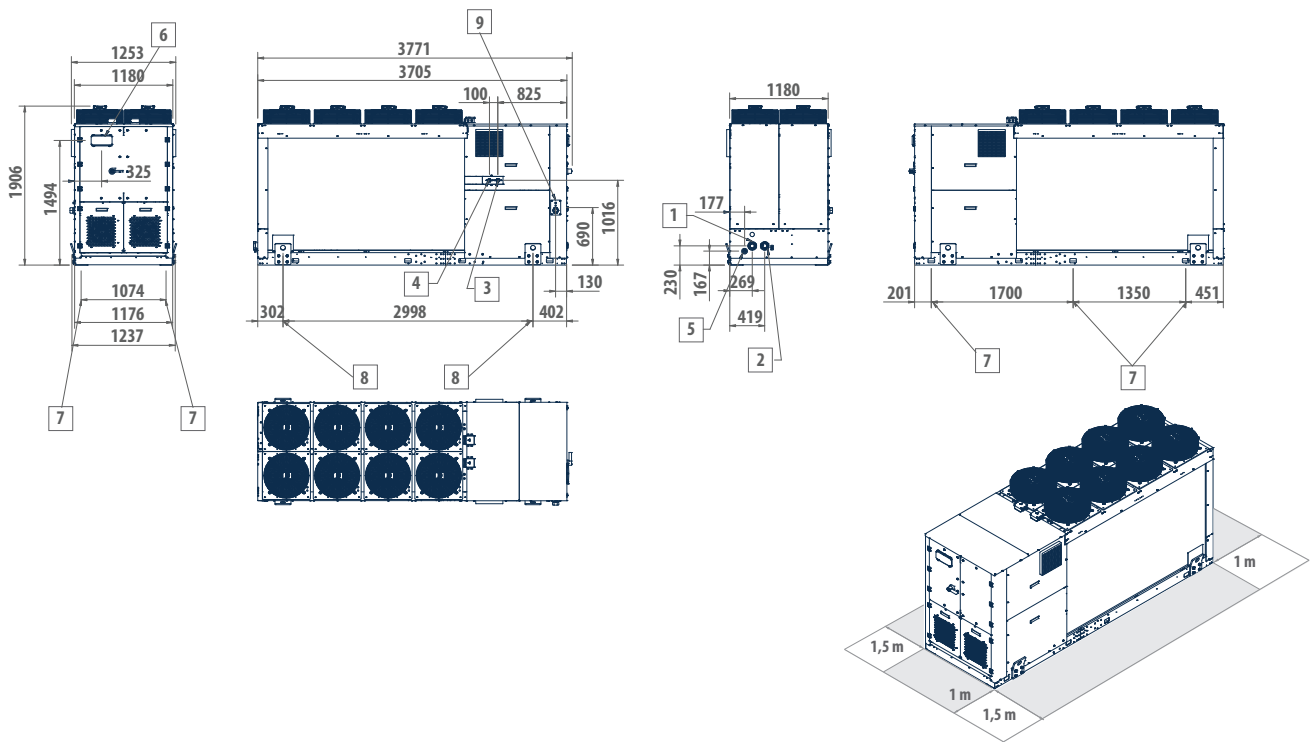

LEGEND

1	Water inlet on user side 2" 1/2 F
2	Water outlet user 2" 1/2 F
3	Desuperheater water inlet 1" F
4	De-superheater water outlet 1" F
5	Water drainage 1/2" F
6	User interface
7	Vibration dampers
8	Lifting points
9	Power supply input

Chillers and heat pumps with natural refrigerant

DIMENSIONAL DRAWINGS

PLN 134 - 154

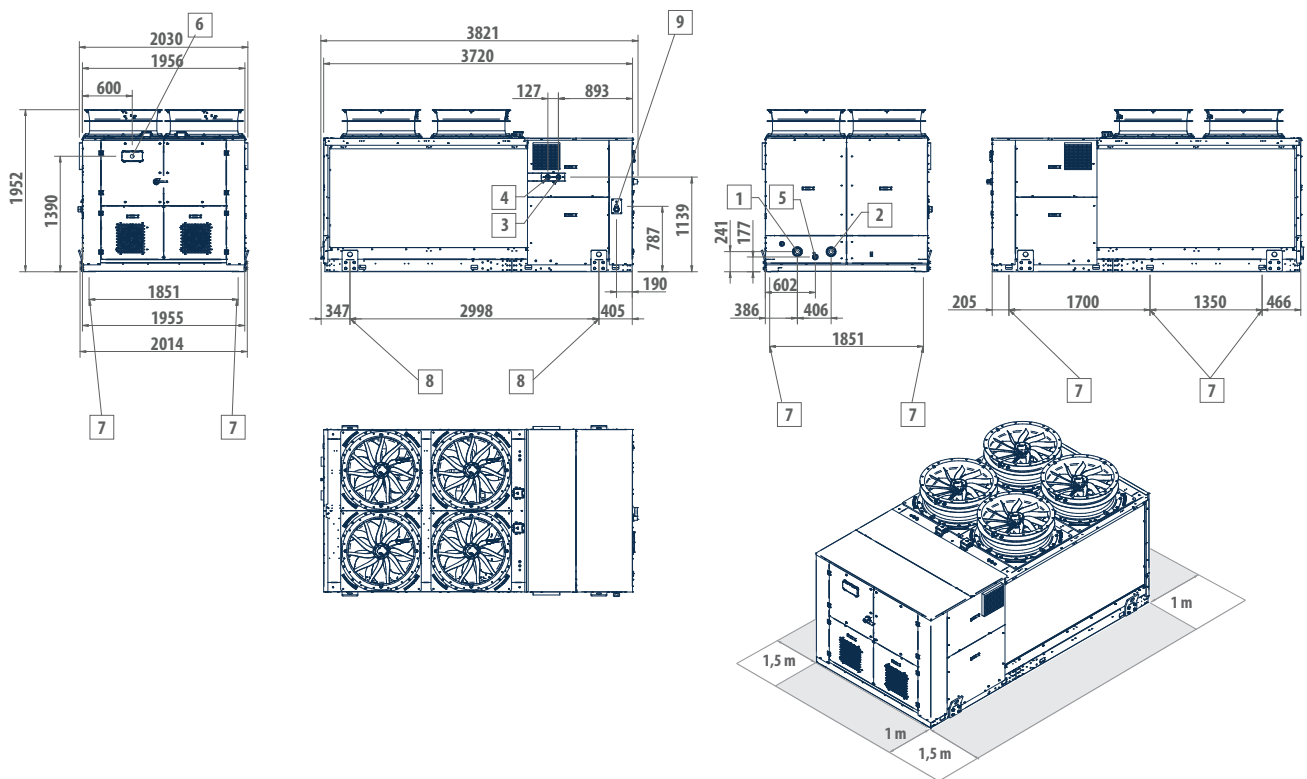

LEGEND

1	Water inlet on user side 3" VIC
2	Water outlet user 3" VIC
3	Desuperheater water inlet 1" 1/2 F
4	De-superheater water outlet 1" 1/2 F
5	Water drainage 1/2" F
6	User interface
7	Vibration dampers
8	Lifting points
9	Power supply input

Outdoor packaged unit

EvitechH 50 - 180 kW



Reliability and efficiency in every climatic condition

EvitechH is Galletti's new high efficiency multiscroll units equipped with R410A steam injection compressor. The range consists of 10 air-water models available as chiller and heat pump, with cooling capacities from 50 to 180 kW.

The main strongpoint of this series is the large operating field, both in terms of maximum hot water temperature (65°C with -11°C of external air temperature) and minimum air temperature at which the continuous operation is allowed (-20°C)

The range allows high configurability from an acoustic point of view, having a wide range of accessories designed to reduce noise emissions. The advanced control, always present in the whole range, allows a continuous monitoring of the operating parameters, advanced adjustment logics, and connectivity.

The modular structure with V configuration condensing coils is designed to optimize air-side heat exchange, to ensure structural strength with a reduced footprint, and to maintain maximum accessibility to the basic components.

In addition to high efficiency in terms of nominal conditions (Eurovent A-class), in order to increase the efficiency at partial loads, the whole range consists of tandem solutions (2 compressors on a single refrigerant circuit).

PLUS

- » Class A in heat pump operating mode
- » Production of hot water up to 65°C
- » Operation at full load with external air temperatures down to -20 °C
- » High efficiency under part load conditions
- » Possibility to configure low-noise versions
- » Counterflow solutions in every operating mode
- » -

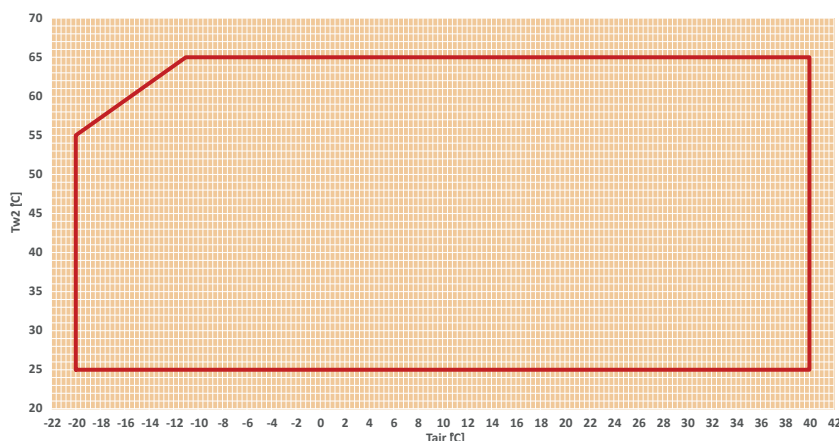

EvitechH heat pumps and are designed for heating or cooling the water to be used in air-conditioning systems for residential, commercial or industrial use. The execution with injection steam compressors (EvitechH) guarantees the production of hot water at high temperatures even in very hard outdoor conditions (up to -20°C).

For detailed informations regarding the operating limits of the unit, refer to the product technical documentation.

MAIN COMPONENTS

Structure

The range is designed modularly, replicating the optimized structure of V configuration condensing coils and fans. Its design ensures stability, sturdiness even during the most critical phases (such as transportation), and maximum accessibility to components in every unit.

Upwind

Evitech is designed with an innovative technology which allows the refrigerant to get into the battery from the same direction when the cycle is inverted, with a constant counter-current exchange with air. This advanced technology considerably reduces the risk of ice generation on the finned heat exchangers.

Scroll compressors with vapour injection

The range consists of single and dual-circuit models in order to offer maximum redundancy. The distribution of load in multiple power steps and the use of tandem solutions (2 compressors on a single circuit) ensures maximum efficiency at partial loads and therefore greatly increases seasonal efficiency. Intercooled compression with steam injection allows a better control of the end-compression temperature, keeping it within the limits imposed by the compressor envelope, even in the most unfavorable working conditions (low evaporation pressures and high compression pressures), this results in one of the largest operating field in the market.

3-way valve

This is a smart kit able to convert Evitech heat pumps in multi-function units in order to fulfill every necessity of the hydraulic air-conditioning plant. It allows domestic hot water priority production thanks to Galletti thermal accumulators of the TP or TN series. The switching of the valve is managed by the on-board microprocessor control of the unit.

CONFIGURATOR

The models are completely configurable by selecting the version and the options. To the right is shown an example of configuration.

Version	Field	1	2	3	4	5	6	7	8	9	10	11	12	13
EVI082HSOA		A	1	S	0	C	0	2	M	0	P	0	0	2

To verify the compatibility of the options, use the selection software or the price list.

AVAILABLE VERSIONS

Reversible heat pump versions

EVI..HS0A	Power supply 400V-3N-50Hz
EVI..HS4A	Power supply 400V-3-50Hz + transformer
EVI..HS2A	Power supply 400V-3N-50H + circuit breaker

CONFIGURATION OPTIONS

1 Expansion valve	8 Refrigerant pipework accessories
A Electronic	0 Absent
2 Water pump and accessories	M Refrigerant pressure gauges
0 Absent	9 Remote control / Serial communication
1 LP pump + expansion vessel	0 Absent
2 LP run and standby double pump + expansion vessel	2 RS485 serial board (Carel / Modbus protocol)
3 HP pump + expansion vessel	B BACNET IP / PCOWEB serial board (advanced controller required)
4 HP run and standby double pump + expansion vessel	F BACNET MS/TP / PCONET serial board (advanced controller required)
A LP inverter pump + expansion vessel	G BACNET IP / PCOWEB serial board + supervision software Gweb (advanced controller required)
B LP run and standby double inverter pump + expansion vessel	S Remote simplified user panel
C HP inverter pump + expansion vessel	T Touch screen remote user panel
D HP run and standby double inverter pump + expansion vessel	X Remote user panel for advanced controller
3 Water buffer tank	10 Special coils / Protective treatments
0 Absent	0 Standard
S Selected	C Cataphoresis treatment on fins and coil carpentry
4 Partial heat recovery	I Hydrophilic
0 Absent	P Pre-painted fins with polyester paint
D Desuperheater with water pump free contact	R Copper-copper
5 Air flow modulation	11 Anti vibration shock mounts
C Condensation control by phase-cut fans	0 Absent
E Condensation control performed by EC fans	G Rubber anti vibration shock mounts
6 Antifreezing kit	M Spring anti vibration shock mounts
0 Absent	12 Coil protection grill
E Plate exchanger	0 Absent
P Plate exchanger and water pump	F Outdoor finned coil heat exchanger protection filters
S Plate exchanger, water pump and inertial tank	G Selected
7 Acoustic insulation and attenuation	13 Onboard controller
0 Absent	1 Advanced
1 Compressor sound blanket and compressor compartment sound proofing	2 Advanced + touchscreen user panel + USB
2 Fans noise reduction (AXITOP)	
3 Fans noise reduction (AXITOP) + compressor sound blanket + compartment acoustic insulation	

ACCESSORIES

A	3 way valve for DHW production (water tank not allowed)	G	Soft starter
B	Low temperature	H	Power factor capacitors
C	Pair of couplings Victaulic	I	Filter regulating kit
D	ON/OFF status of the compressors	M	0-10 V signal for external user pump control (on-board pump excluded)
E	Remote control for step capacity limit (advanced controller required)	N	Compressor tandem/trio isolation valves
F	Configurable digital alarm board (advanced controller required)	O	Anti-intrusion grille

Air heat pumps with wide working range EvitecH

EVITECH HEAT PUMPS RATED TECHNICAL DATA

EvitecH			052	062	072	082	092
Power supply		V-ph-Hz	400 - 3N - 50				
Cooling capacity	(1)(E)	kW	50,5	60,8	71,3	80,2	90,4
Total power input	(1)(E)	kW	17,9	21,3	24,1	27,0	31,2
EER	(1)(E)		2,82	2,85	2,96	2,97	2,90
SEER	(2)(E)		3,75	3,81	3,72	3,74	3,81
Water flow	(1)	l/h	8682	10469	12272	13806	15552
Water pressure drop	(1)(E)	kPa	21	30	29	37	26
Available pressure head - LP pumps	(1)	kPa	167	150	147	188	183
Heating capacity	(3)(E)	kW	59,7	70,3	82,9	92,1	105
Total power input	(3)(E)	kW	18,1	21,1	25,5	27,9	31,4
COP	(3)(E)		3,30	3,33	3,26	3,31	3,33
SCOP	(2)(E)		2,85	2,92	2,85	2,90	2,98
Heating energy efficiency class	(4)		A+				
SCOP	(2)(E)		3,70	3,74	3,54	3,65	3,75
Heating energy efficiency class	(5)		A+				
Water flow	(3)	l/h	10352	12179	14365	15959	18113
Water pressure drop	(3)(E)	kPa	30	41	40	50	36
Available pressure head - LP pumps	(3)	kPa	150	128	123	156	148
Maximum current absorption		A	55,0	65,0	73,0	74,0	83,0
Start up current		A	152	179	214	215	203
Startup current with soft starter		A	111	130	153	154	144
Compressors / circuits			2/1				
Expansion vessel volume		dm ³	8	8	18	18	18
Buffer tank volume		dm ³	125	125	320	320	320
Sound power level	(6)(E)	dB(A)	82	82	83	83	83
Transport weight unit with pump and tank		kg	793	802	1081	1082	1095
Operating weight unit with pump and full tank		kg	895	904	1408	1412	1422

(1) Outdoor air temperature 35°C, water temperature 12°C / 7°C (EN14511:2022)

(2) η efficiency values for heating and cooling are respectively calculated by the following formulas: $[\eta = SCOP / 2,5 - F(1) - F(2)]$ e $[\eta = SEER / 2,5 - F(1) - F(2)]$. For further information, please refer to the technical document "ErP 2009/125/EC DIRECTIVE" in the catalogue introducing pages, or to the EN14825:2022 regulation.

(3) Outdoor air temperature dry bulb 7°C / wet bulb 6°C, water temperature 40°C / 45°C (EN14511:2022)

(4) Seasonal energy efficiency class for MEDIUM TEMPERATURE room heating under AVERAGE climatic conditions [EUROPEAN REGULATION No 811/2013. The energy efficiency class of this product is included in the range A+++ → D]

(5) Seasonal energy efficiency class for LOW TEMPERATURE room heating under AVERAGE climatic conditions [EUROPEAN REGULATION No 811/2013. The energy efficiency class of this product is included in the range A+++ → D]

(6) Sound power level measured according to ISO 9614

(E) EUROVENT certified data

EVITECH HEAT PUMPS RATED TECHNICAL DATA

Evitech			104	124	154	174	184
Power supply		V-ph-Hz	400 - 3N - 50				
Cooling capacity	(1)(E)	kW	104	124	150	172	182
Total power input	(1)(E)	kW	36,6	44,8	51,2	58,2	62,7
EER	(1)(E)		2,85	2,77	2,94	2,95	2,90
SEER	(2)(E)		3,78	3,88	4,02	4,23	4,20
Water flow	(1)	l/h	17903	21369	25873	29515	31259
Water pressure drop	(1)(E)	kPa	32	23	33	24	27
Available pressure head - LP pumps	(1)	kPa	136	137	162	165	159
Heating capacity	(3)(E)	kW	118	139	173	194	206
Total power input	(3)(E)	kW	34,6	40,8	51,7	56,6	60,4
COP	(3)(E)		3,42	3,40	3,34	3,43	3,41
SCOP	(2)(E)		2,94	2,96	3,00	3,11	3,14
Heating energy efficiency class	(4)		A+				
SCOP	(2)(E)		3,73	3,80	3,88	4,05	4,08
Heating energy efficiency class	(5)		A+	A+	A++	A++	A++
Water flow	(3)	l/h	20509	24067	29949	33643	35781
Water pressure drop	(3)(E)	kPa	42	29	44	31	35
Available pressure head - LP pumps	(3)	kPa	117	119	142	148	138
Maximum current absorption		A	92,0	112	147	156	165
Start up current		A	189	226	288	297	296
Startup current with soft starter		A	148	177	227	237	237
Compressors / circuits			4/2				
Expansion vessel volume		dm ³	18	18	24	24	24
Buffer tank volume		dm ³	320	320	450	450	450
Sound power level	(6)(E)	dB(A)	84	87	87	87	87
Transport weight unit with pump and tank		kg	1249	1265	2064	2102	2120
Operating weight unit with pump and full tank		kg	1576	1592	2491	2529	2547

(1) Outdoor air temperature 35°C, water temperature 12°C / 7°C (EN14511:2022)

(2) η efficiency values for heating and cooling are respectively calculated by the following formulas: $[\eta = SCOP / 2,5 - F(1) - F(2)]$ e $[\eta = SEER / 2,5 - F(1) - F(2)]$. For further information, please refer to the technical document "ErP 2009/125/EC DIRECTIVE" in the catalogue introducing pages, or to the EN14825:2022 regulation.

(3) Outdoor air temperature dry bulb 7°C / wet bulb 6°C, water temperature 40°C / 45°C (EN14511:2022)

(4) Seasonal energy efficiency class for MEDIUM TEMPERATURE room heating under AVERAGE climatic conditions [EUROPEAN REGULATION No 811/2013. The energy efficiency class of this product is included in the range A+++ → D]

(5) Seasonal energy efficiency class for LOW TEMPERATURE room heating under AVERAGE climatic conditions [EUROPEAN REGULATION No 811/2013. The energy efficiency class of this product is included in the range A+++ → D]

(6) Sound power level measured according to ISO 9614

(E) EUROVENT certified data

Air heat pumps with wide working range Evitech

DIMENSIONAL DRAWINGS

EVITECH 52 - 62

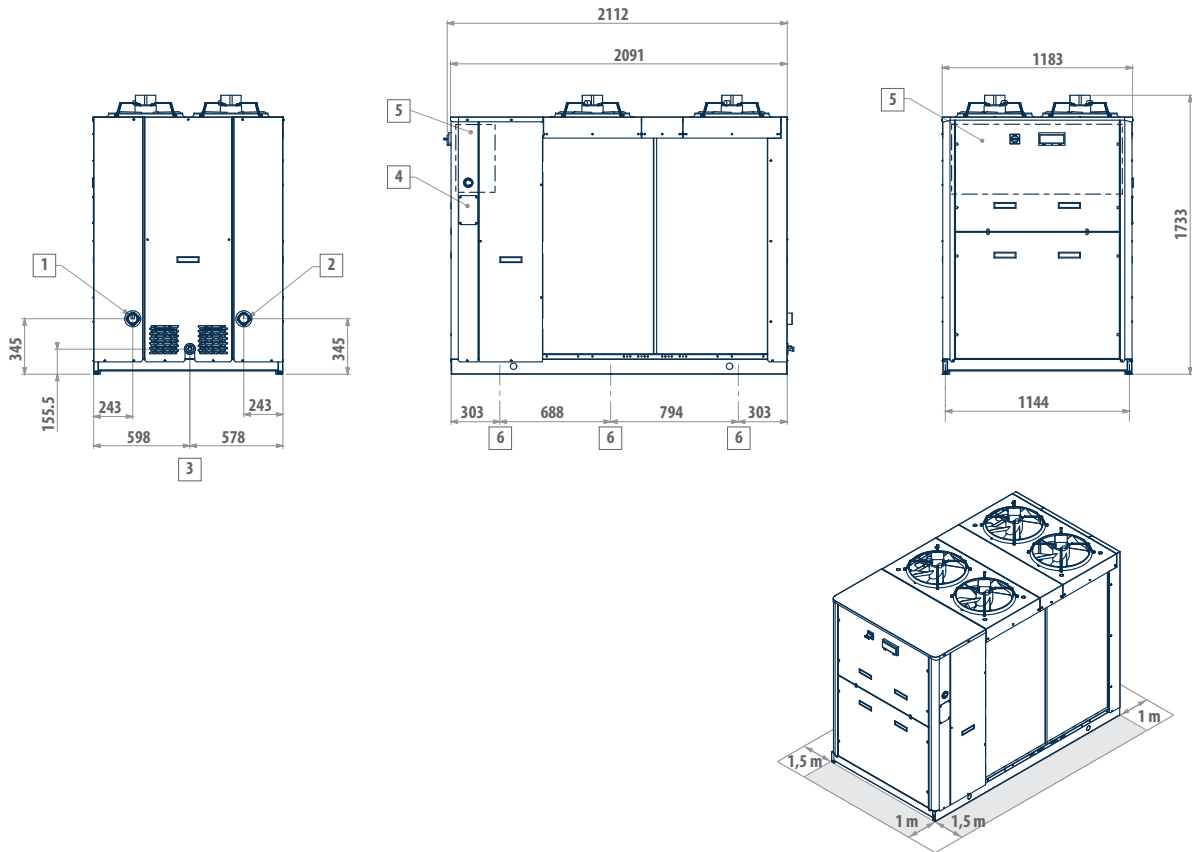

LEGEND

1	Water inlet 2" female
2	Water outlet 2" female
3	Water drainage 1/2" female
4	Power supply
5	Electric control board
6	Fastening points for vibration dampers

DIMENSIONAL DRAWINGS

EVITECH 72 - 82 - 92

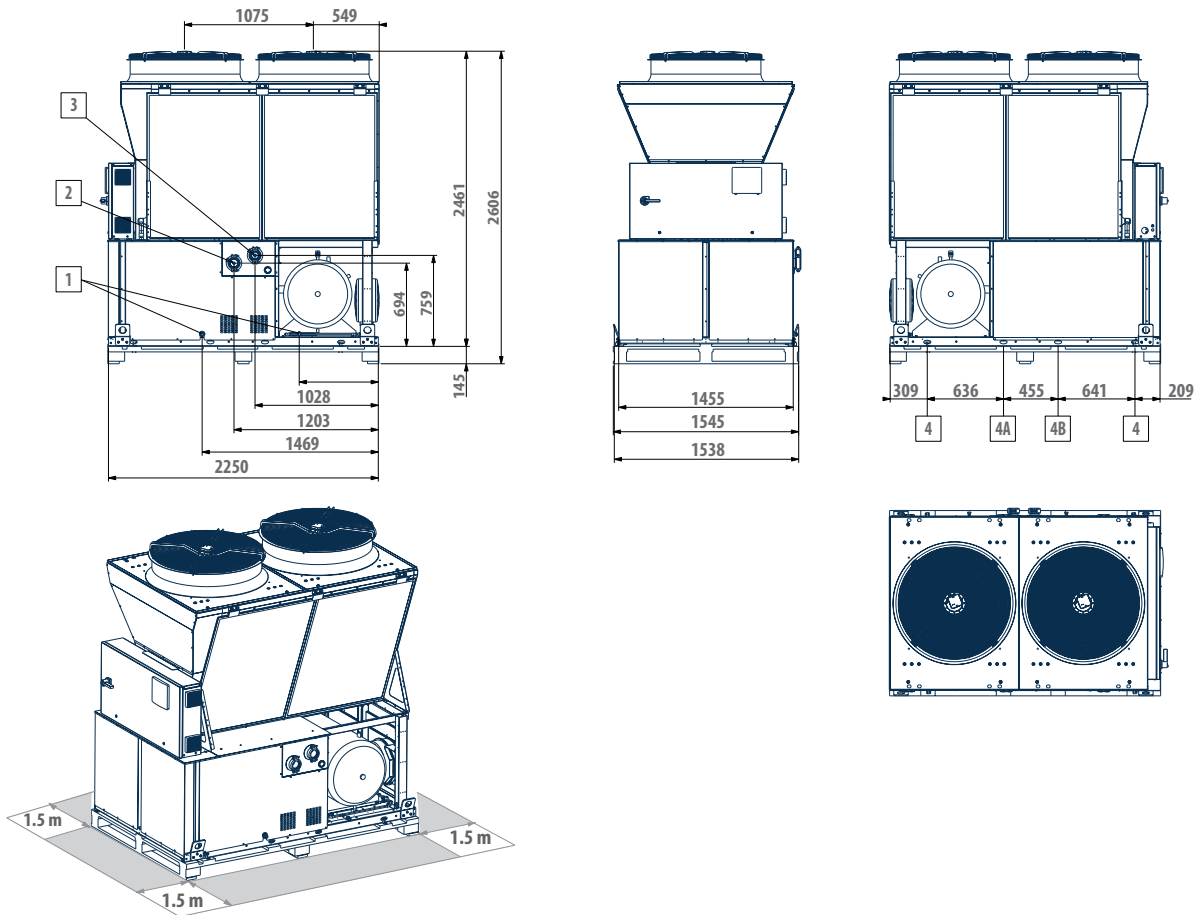

LEGEND

- | | |
|---|-------------------------------|
| 1 | Water drainage 1/2" female |
| 2 | Water inlet Victaulic 2 1/2" |
| 3 | Water outlet Victaulic 2 1/2" |
| 4 | Vibration dumpers |

Air heat pumps with wide working range Evitech

DIMENSIONAL DRAWINGS

EVITECH 104 - 124

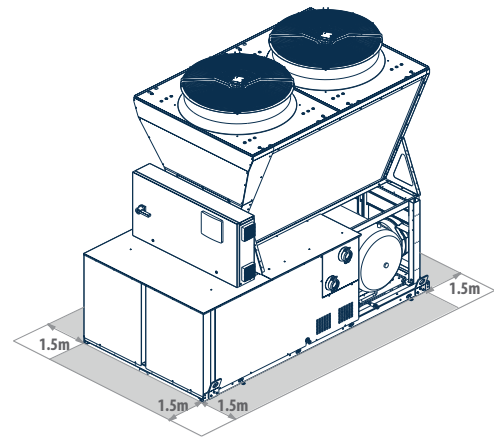
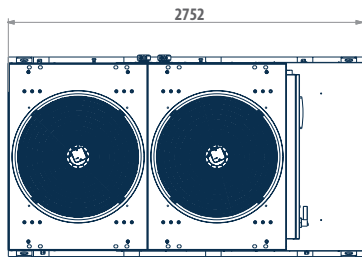
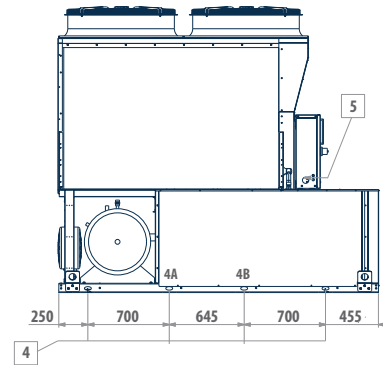
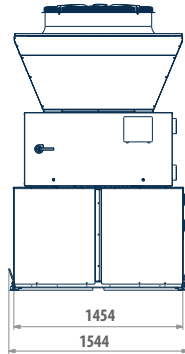
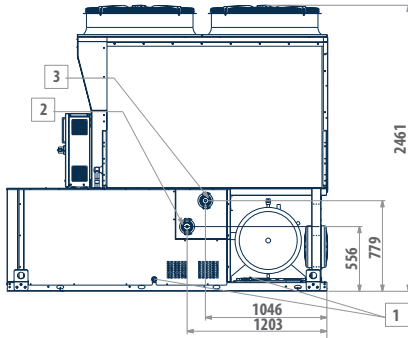

LEGEND

- | | |
|---|-------------------------------|
| 1 | Water drainage 1/2" female |
| 2 | Water inlet Victaulic 2 1/2" |
| 3 | Water outlet Victaulic 2 1/2" |
| 4 | Vibration dumpers |

DIMENSIONAL DRAWINGS

EVITECH 154 - 174 - 184

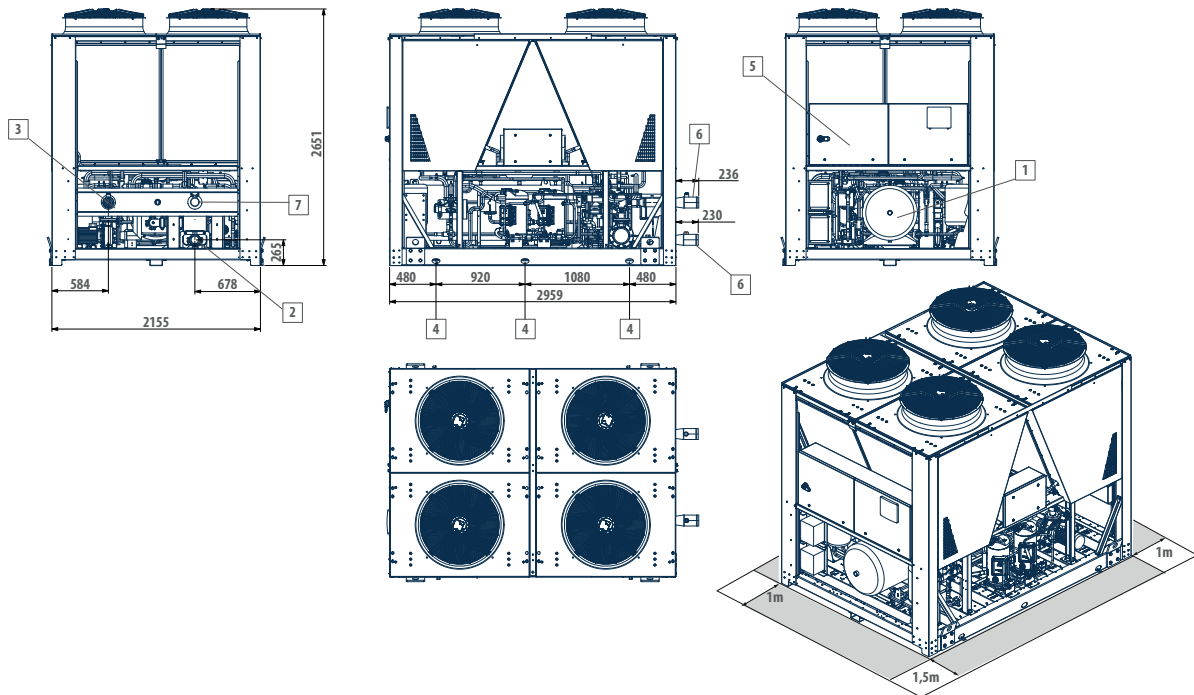

LEGEND

1	Water drainage 1/2" female
2	Water inlet Victaulic 4"
3	Water outlet Victaulic 4"
4	Vibration dumpers
5	Electric control board
6	Victaulic adapter from 4" to 3" to be mounted on-site
7	Water outlet, evaporator only

Air heat pumps with wide working range - Evitech

Outdoor packaged unit

LCX 55 - 360 kW

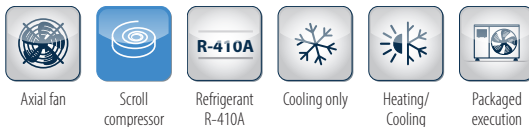

LCX: wide range of models and configurability

The main feature of the new LCX design is its extremely wide range: the 16 models that comprise it can be built as chiller, free cooling, or heat pump versions, in 2 different acoustic configurations, and cover a range of powers from 55 to 360 kW.

The possibility of setting up different cooling circuits in units of the same power means being able to personalise efficiency levels under full or part load conditions.

- 1 circuit, 2 compressors. The solution of using two compressors in a single cooling circuit increases efficiency under part load conditions, reaching ESEER/SEER and SCOP values greater than 4.
- 2 circuits / 4 compressors, 4 compressors enable the unit to output power in 4 steps and adapt perfectly to the actual thermal load of the system, while reducing starting currents.

Complete hydronic kits can be incorporated within the units without modifying their size and you have the option of choosing the water circulation pump.

All units, irrespective of type of construction, are equipped with electronic expansion valves to maximise efficiency under part load conditions.

PLUS

- » Super low noise execution available on request
- » Electronic expansion valve
- » Incorporable hydraulic kit
- » Up to 4 compressors
- » 1 or 2 cooling circuits
- » Remote connectivity with the most common protocols
- » Super low noise execution available on request

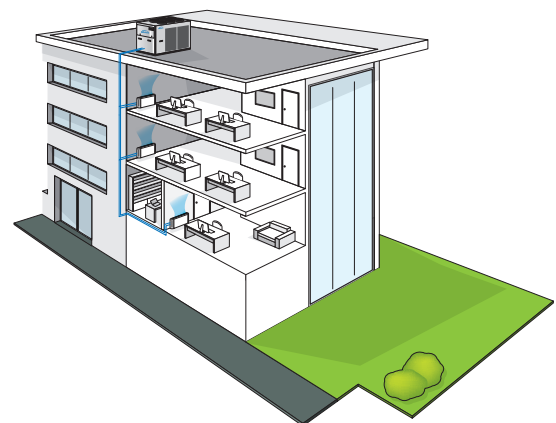

LCX heat pumps and water chillers are designed for heating or cooling the water to be used in air-conditioning systems for residential, commercial or industrial use.

MAIN COMPONENTS

Structure

Made in galvanised steel sheet with a polyester powder coating for outdoors. The compressor compartment is completely sealed and may be accessed on 3 sides thanks to easy-to-remove panels that greatly simplify maintenance and/or inspection.

Scroll compressors

Scroll compressors are now the best solution in terms of reliability and limiting the sound power emitted. The compressors are supplied complete with motor protection against overheating, overcurrents and excessive outlet gas temperatures.

Heat exchanger

Made of generously sized aluminum fins and copper piping. The special engineering allows defrost cycles to be carried out at maximum speed in the models with heat pump operation, which brings clear benefits in terms of the integrated efficiency of the whole cycle.

Electronic microprocessor control

It completely manages the unit. The electronic control system allows the setpoint to be adjusted automatically according to the outdoor temperature in order to reduce consumption and broaden the working temperature range. With the advanced microprocessor control it is possible to set up LAN networks for controlling up to 4 units in parallel.

Fan drive assembly

Axial fans with airfoil blades made of plastic-aluminum composite, connected to an electric motor with external rotor. The condensation control system continuously and automatically regulates the fan speed. Electric fans with BLDC motor are available on request.



Cooling circuit

It can be made in two different versions with the same power (Efficiency Pack), using mainly:

- R410A scroll compressors
- brazed plate heat exchangers
- finned block condenser
- electronic expansion valve



CONFIGURATOR

The models are completely configurable by selecting the version and the options. To the right is shown an example of configuration.

Version	Field	1	2	3	4	5	6	7	8	9	10	11	12	13
LCX092HL		0	B	1	S	0	0	S	1	0	0	G	0	V

To verify the compatibility of the options, use the selection software or the price list.

AVAILABLE VERSIONS

Only cooling versions

- LCX..CSGO** Standard execution
- LCX..CLGO** Low noise execution
- LCX..CQGO** Super low noise execution (on request)

Reversible heat pump versions

- LCX..HSGO** Standard execution
- LCX..HLGO** Low noise execution
- LCX..HQGO** Super low noise execution (on request)

CONFIGURATION OPTIONS

1 Power supply

- 0 400 V - 3 N - 50 Hz
- 1 400 V - 3 - 50 Hz
- 2 400 V - 3 N - 50 Hz + magnetic breakers
- 3 400 V - 3 - 50 Hz + magnetic breakers

2 Onboard controller and expansion valve

- B Advanced + electronic expansion valve

3 User side water pump (*)

- 0 Absent
- 1 LP pump + expansion vessel
- 2 HP pump + expansion vessel
- 3 Double pump LP parallel operation and expansion vessel
- 4 Double pump HP parallel operation and expansion vessel
- 5 LP run and standby double pump + expansion vessel
- 6 HP run and standby double pump + expansion vessel

4 Water buffer tank

- 0 Absent
- S Selected user side

5 Partial heat recovery

- 0 Absent
- D Desuperheater with water pump free contact

6 Air flow modulation

- 0 Absent
- C Condensation control by phase-cut fans
- E Condensation control performed by EC fans

7 Antifreezing kit

- 0 Absent
- E Evaporator
- P Evaporator and water pump

- S Evaporator, water pump and water buffer tank

8 Remote communication

- 0 Absent
- 1 RS485 serial board (Carel / Modbus protocol)
- 3 GSM modem board
- 4 BACNET IP / PCOWEB serial board + supervision software Gweb
- 5 BACNET IP / PCOWEB serial board + clock board + supervision software Gweb

9 Special coils / Protective treatments

- 0 Standard
- B Pre-painted fins with polyester paint
- C Cataphoresis treatment on fins and coil carpentry
- R Copper-copper

10 Packing

- 0 Standard
- 1 Wooden cage
- 2 Wooden crate

11 Anti vibration shock mounts

- 0 Absent
- G Rubber anti vibration shock mounts
- M Spring anti vibration shock mounts

12 Remote control

- 0 Absent
- 1 Remote simplified user panel
- 3 Remote user panel for advanced controller

13 Unit installation accessories

- 0 Absent
 - V Pair of couplings Victaulic
- (*) Inverter versions also available

ACCESSORIES

A	Power factor capacitors	H	Set point compensation outdoor temperature probe
B	Soft starter	I	Refrigerant pressure gauges
C	Service kit (advanced controller required)	L	Filter regulating kit
D	Clock board (included with advanced controller)	M	Directives reference other than "2014/68/UE - PED"
E	ON/OFF status of the compressors	N	Unit lifting pipes
F	Remote control for step capacity limit (advanced controller required)	P	Outdoor finned coil heat exchanger protection grille
G	Configurable digital alarm board (advanced controller required)	Q	Outdoor finned coil heat exchanger protection filters

Air chillers and heat pumps LCX

LCX CS WATER CHILLERS RATED TECHNICAL DATA

LCX CS			92	102	122	124	142	144	162
Power supply		V-ph-Hz	400 - 3N - 50						
Cooling capacity	(1)(E)	kW	88,8	102	113	118	144	143	160
Total power input	(1)(E)	kW	32,1	35,9	40,4	42,8	50,9	50,8	58,9
EER	(1)(E)		2,77	2,83	2,80	2,76	2,83	2,82	2,71
SEER	(2)(E)		4,14	4,45	4,15	4,11	4,14	4,20	4,32
Water flow	(1)	l/h	15285	17530	19470	20283	24766	24674	27492
Water pressure drop	(1)(E)	kPa	32	32	34	34	36	36	36
Available pressure head - LP pumps	(1)	kPa	128	125	113	114	174	168	158
Maximum current absorption		A	91,0	101	119	120	131	129	144
Start up current		A	261	269	319	247	330	245	396
Startup current with soft starter		A	199	207	254	172	265	186	313
Compressors / circuits			2 / 1	2 / 1	2 / 1	4 / 2	2 / 1	4 / 2	2 / 1
Expansion vessel volume		dm ³	12	12	12	12	12	12	12
Buffer tank volume		dm ³	220	220	340	340	340	340	340
Sound power level	(3)(E)	dB(A)	86	86	86	85	87	85	87
Transport weight unit with pump and tank		kg	918	918	1241	1301	1286	1321	1316
Operating weight unit with pump and full tank		kg	1138	1138	1581	1641	1626	1661	1656

LCX CS			164	174	194	214	244	274	294
Power supply		V-ph-Hz	400 - 3N - 50						
Cooling capacity	(1)(E)	kW	152	162	183	202	245	264	294
Total power input	(1)(E)	kW	56,4	58,2	65,6	76,2	95,7	90,5	104
EER	(1)(E)		2,70	2,78	2,79	2,65	2,56	2,91	2,82
SEER	(2)(E)		4,19	4,13	4,28	4,31	4,19	4,33	4,37
Water flow	(1)	l/h	26160	27855	31447	34689	42201	45368	50493
Water pressure drop	(1)(E)	kPa	36	37	37	38	38	39	40
Available pressure head - LP pumps	(1)	kPa	159	170	150	161	196	183	170
Maximum current absorption		A	150	136	155	173	196	224	237
Start up current		A	266	252	310	330	380	403	468
Startup current with soft starter		A	214	200	248	268	315	338	385
Compressors / circuits			4 / 2						
Expansion vessel volume		dm ³	12	24	24	24	24	24	24
Buffer tank volume		dm ³	340	600	600	600	600	765	765
Sound power level	(3)(E)	dB(A)	85	88	88	89	89	89	89
Transport weight unit with pump and tank		kg	1471	1608	1676	1686	1869	2129	2161
Operating weight unit with pump and full tank		kg	1811	2208	2276	2286	2469	2894	2926

(1) Outdoor air temperature 35°C, water temperature 12°C / 7°C (EN14511:2022)

(2) η efficiency values for heating and cooling are respectively calculated by the following formulas: $[\eta = SCOP / 2,5 - F(1) - F(2)]$ e $[\eta = SEER / 2,5 - F(1) - F(2)]$. For further information, please refer to the technical document "ErP 2009/125/EC DIRECTIVE" in the catalogue introducing pages, or to the EN14825:2022 regulation.

(3) Sound power level measured according to ISO 9614

(E) EUROVENT certified data

LCX CS WATER CHILLERS RATED TECHNICAL DATA

LCX CS			324	364
Power supply		V-ph-Hz	400 - 3N - 50	
Cooling capacity	(1)(E)	kW	318	355
Total power input	(1)(E)	kW	120	138
EER	(1)(E)		2,66	2,57
SEER	(2)(E)		4,12	4,15
Water flow	(1)	l/h	54657	60969
Water pressure drop	(1)(E)	kPa	39	41
Available pressure head - LP pumps	(1)	kPa	162	143
Maximum current absorption		A	251	300
Start up current		A	476	497
Startup current with soft starter		A	393	440
Compressors / circuits			4 / 2	
Expansion vessel volume		dm ³	24	24
Buffer tank volume		dm ³	765	765
Sound power level	(3)(E)	dB(A)	89	90
Transport weight unit with pump and tank		kg	2196	2196
Operating weight unit with pump and full tank		kg	2961	2961

(1) Outdoor air temperature 35°C, water temperature 12°C / 7°C (EN14511:2022)

(2) η efficiency values for heating and cooling are respectively calculated by the following formulas: $[\eta = SCOP / 2,5 - F(1) - F(2)]$ e $[\eta = SEER / 2,5 - F(1) - F(2)]$. For further information, please refer to the technical document "ErP 2009/125/EC DIRECTIVE" in the catalogue introducing pages, or to the EN14825:2022 regulation.

(3) Sound power level measured according to ISO 9614

(E) EUROVENT certified data

Air chillers and heat pumps LCX

LCX HS HEAT PUMPS RATED TECHNICAL DATA

LCX HS			092	102	122	124	142	144	162	
Power supply		V-ph-Hz	400 - 3N - 50							
Cooling capacity	(1)(E)	kW	87,7	100	112	117	142	141	157	
Total power input	(1)(E)	kW	32,0	35,3	40,4	41,9	50,8	50,7	58,8	
EER	(1)(E)		2,74	2,84	2,76	2,80	2,79	2,79	2,68	
SEER	(2)(E)		4,11	4,38	4,02	3,97	4,10	4,16	4,27	
Water flow	(1)	l/h	15080	17276	19183	20189	24399	24308	27085	
Water pressure drop	(1)(E)	kPa	24	26	27	25	31	31	32	
Available pressure head - LP pumps	(1)	kPa	136	131	121	123	177	173	161	
Heating capacity	(3)(E)	kW	107	120	133	146	166	168	187	
Total power input	(3)(E)	kW	30,0	34,2	38,1	41,7	47,7	47,3	53,2	
COP	(3)(E)		3,55	3,50	3,50	3,51	3,49	3,55	3,51	
SCOP	(2)(E)		4,22	4,30	4,18	4,11	4,13	4,10	4,15	
Heating energy efficiency class	(4)(E)		A++							
Water flow	(3)	l/h	18461	20768	23116	25387	28831	29176	32378	
Water pressure drop	(3)(E)	kPa	36	37	39	39	43	44	46	
Available pressure head - LP pumps	(3)	kPa	130	123	113	114	162	156	139	
Maximum current absorption		A	91,0	101	119	120	131	129	144	
Start up current		A	261	269	319	247	330	245	396	
Startup current with soft starter		A	199	207	254	172	265	186	313	
Compressors / circuits			2 / 1	2 / 1	2 / 1	4 / 2	2 / 1	4 / 2	2 / 1	
Expansion vessel volume		dm ³	12	12	12	12	12	12	12	
Buffer tank volume		dm ³	220	220	340	340	340	340	340	
Sound power level	(5)(E)	dB(A)	86	86	86	85	87	85	87	
Transport weight unit with pump and tank		kg	918	918	1241	1301	1286	1321	1316	
Operating weight unit with pump and full tank		kg	1138	1138	1581	1641	1626	1661	1656	

LCX HS			164	174	194	214	244	274	294	
Power supply		V-ph-Hz	400 - 3N - 50							
Cooling capacity	(1)(E)	kW	150	160	180	199	242	260	289	
Total power input	(1)(E)	kW	56,3	58,1	65,6	76,2	95,7	90,4	104	
EER	(1)(E)		2,66	2,74	2,74	2,61	2,53	2,88	2,77	
SEER	(2)(E)		4,15	3,45	3,64	3,67	3,55	3,69	3,73	
Water flow	(1)	l/h	25773	27443	30948	34175	41577	44698	49746	
Water pressure drop	(1)(E)	kPa	32	34	34	35	35	35	35	
Available pressure head - LP pumps	(1)	kPa	162	172	152	164	198	186	173	
Heating capacity	(3)(E)	kW	181	189	213	232	281	308	342	
Total power input	(3)(E)	kW	50,7	56,9	64,6	71,0	85,6	88,7	99,5	
COP	(3)(E)		3,56	3,32	3,31	3,27	3,28	3,47	3,44	
SCOP	(2)(E)		4,07	3,57	3,64	3,64	3,66	3,71	3,74	
Heating energy efficiency class	(4)(E)		A++	A+	A+	A+	A+	A+	A+	
Water flow	(3)	l/h	31359	32758	37031	40301	48719	53462	59409	
Water pressure drop	(3)(E)	kPa	47	48	48	48	48	50	50	
Available pressure head - LP pumps	(3)	kPa	141	155	129	136	181	167	153	
Maximum current absorption		A	150	136	155	173	196	224	237	
Start up current		A	266	252	310	330	380	403	468	
Startup current with soft starter		A	214	200	248	268	315	338	385	
Compressors / circuits			4 / 2							
Expansion vessel volume		dm ³	12	24	24	24	24	24	24	
Buffer tank volume		dm ³	340	600	600	600	600	765	765	
Sound power level	(5)(E)	dB(A)	85	88	88	89	89	89	89	
Transport weight unit with pump and tank		kg	1471	1608	1676	1686	1869	2129	2161	
Operating weight unit with pump and full tank		kg	1811	2208	2276	2286	2469	2894	2926	

(1) Outdoor air temperature 35°C, water temperature 12°C / 7°C (EN14511:2022)

(2) η efficiency values for heating and cooling are respectively calculated by the following formulas: $[\eta = SCOP / 2,5 - F(1) - F(2)]$ e $[\eta = SEER / 2,5 - F(1) - F(2)]$. For further information, please refer to the technical document "ErP 2009/125/EC DIRECTIVE" in the catalogue introducing pages, or to the EN14825:2022 regulation.

(3) Outdoor air temperature dry bulb 7°C / wet bulb 6°C, water temperature 40°C / 45°C (EN14511:2022)

(4) Seasonal energy efficiency class for LOW TEMPERATURE room heating under AVERAGE climatic conditions [EUROPEAN REGULATION No 811/2013. The energy efficiency class of this product is included in the range A+++ → D]

(5) Sound power level measured according to ISO 9614

(E) EUROVENT certified data

LCX HS HEAT PUMPS RATED TECHNICAL DATA

LCX HS			324	364
Power supply		V-ph-Hz	400 - 3N - 50	
Cooling capacity	(1)(E)	kW	324	349
Total power input	(1)(E)	kW	119	138
EER	(1)(E)		2,72	2,53
SEER	(2)(E)		3,86	4,04
Water flow	(1)	l/h	55669	60026
Water pressure drop	(1)(E)	kPa	37	35
Available pressure head - LP pumps	(1)	kPa	165	147
Heating capacity	(3)(E)	kW	374	418
Total power input	(3)(E)	kW	110	128
COP	(3)(E)		3,39	3,26
SCOP	(2)(E)		3,75	3,70
Heating energy efficiency class	(4)(E)		A+	
Water flow	(3)	l/h	64891	72629
Water pressure drop	(3)(E)	kPa	51	51
Available pressure head - LP pumps	(3)	kPa	139	104
Maximum current absorption		A	251	300
Start up current		A	476	497
Startup current with soft starter		A	393	440
Compressors / circuits			4 / 2	
Expansion vessel volume		dm ³	24	24
Buffer tank volume		dm ³	765	765
Sound power level	(5)(E)	dB(A)	89	90
Transport weight unit with pump and tank		kg	2196	2196
Operating weight unit with pump and full tank		kg	2961	2961

(1) Outdoor air temperature 35°C, water temperature 12°C / 7°C (EN14511:2022)

(2) η efficiency values for heating and cooling are respectively calculated by the following formulas: $[\eta = SCOP / 2,5 - F(1) - F(2)]$ e $[\eta = SEER / 2,5 - F(1) - F(2)]$. For further information, please refer to the technical document "ErP 2009/125/EC DIRECTIVE" in the catalogue introducing pages, or to the EN14825:2022 regulation.

(3) Outdoor air temperature dry bulb 7°C / wet bulb 6°C, water temperature 40°C / 45°C (EN14511:2022)

(4) Seasonal energy efficiency class for LOW TEMPERATURE room heating under AVERAGE climatic conditions [EUROPEAN REGULATION No 811/2013. The energy efficiency class of this product is included in the range A+++ → D]

(5) Sound power level measured according to ISO 9614

(E) EUROVENT certified data

Air chillers and heat pumps LCX

LCX CL WATER CHILLERS RATED TECHNICAL DATA

LCX CL			062	072	082	092	094	102	104	
Power supply		V-ph-Hz	400 - 3N - 50							
Cooling capacity	(1)(E)	kW	58,3	66,7	78,6	88,9	90,6	102	105	
Total power input	(1)(E)	kW	20,3	22,9	26,5	31,0	31,4	35,1	35,9	
EER	(1)(E)		2,88	2,91	2,97	2,87	2,89	2,90	2,91	
SEER	(2)(E)		4,13	4,39	4,64	4,40	4,15	4,67	4,46	
Water flow	(1)	l/h	10031	11481	13526	15297	15594	17545	18027	
Water pressure drop	(1)(E)	kPa	28	29	31	32	32	32	34	
Available pressure head - LP pumps	(1)	kPa	140	135	131	127	127	125	125	
Maximum current absorption		A	51,0	55,0	66,0	77,0	81,0	86,0	87,0	
Start up current		A	185	183	191	246	194	254	198	
Startup current with soft starter		A	111	124	139	184	122	192	137	
Compressors / circuits			2 / 1	2 / 1	2 / 1	2 / 1	4 / 2	2 / 1	4 / 2	
Expansion vessel volume		dm ³	12	12	12	12	12	12	12	
Buffer tank volume		dm ³	220	220	220	340	340	340	340	
Sound power level	(3)(E)	dB(A)	80	80	80	81	80	81	80	
Transport weight unit with pump and tank		kg	762	767	847	1086	1217	1096	1217	
Operating weight unit with pump and full tank		kg	982	987	1067	1426	1557	1436	1557	

LCX CL			122	124	142	144	162	164	194	
Power supply		V-ph-Hz	400 - 3N - 50							
Cooling capacity	(1)(E)	kW	113	117	128	133	160	152	178	
Total power input	(1)(E)	kW	40,1	41,0	46,6	46,4	58,5	56,1	63,6	
EER	(1)(E)		2,82	2,85	2,74	2,87	2,74	2,72	2,79	
SEER	(2)(E)		4,15	4,23	4,10	4,16	4,20	4,15	4,21	
Water flow	(1)	l/h	19453	20090	21967	22953	27613	26228	30531	
Water pressure drop	(1)(E)	kPa	34	34	36	36	37	37	37	
Available pressure head - LP pumps	(1)	kPa	111	109	165	162	152	153	154	
Maximum current absorption		A	95,0	96,0	106	105	120	126	148	
Start up current		A	295	220	306	222	371	241	307	
Startup current with soft starter		A	230	146	241	163	288	189	245	
Compressors / circuits			2 / 1	4 / 2	2 / 1	4 / 2	2 / 1	4 / 2	4 / 2	
Expansion vessel volume		dm ³	24	24	24	24	24	24	24	
Buffer tank volume		dm ³	600	600	600	600	600	600	600	
Sound power level	(3)(E)	dB(A)	83	80	84	80	84	80	85	
Transport weight unit with pump and tank		kg	1440	1455	1490	1470	1510	1620	1676	
Operating weight unit with pump and full tank		kg	2040	2055	2090	2070	2110	2220	2276	

(1) Outdoor air temperature 35°C, water temperature 12°C / 7°C (EN14511:2022)

(2) η efficiency values for heating and cooling are respectively calculated by the following formulas: $[\eta = SCOP / 2,5 - F(1) - F(2)]$ e $[\eta = SEER / 2,5 - F(1) - F(2)]$. For further information, please refer to the technical document "ErP 2009/125/EC DIRECTIVE" in the catalogue introducing pages, or to the EN14825:2022 regulation.

(3) Sound power level measured according to ISO 9614

(E) EUROVENT certified data

LCX CL WATER CHILLERS RATED TECHNICAL DATA

LCX CL			214	244	274	294	324	364
Power supply		V-ph-Hz	400 - 3N - 50					
Cooling capacity	(1)(E)	kW	198	220	256	279	316	338
Total power input	(1)(E)	kW	74,2	83,9	90,0	107	122	150
EER	(1)(E)		2,66	2,62	2,84	2,59	2,59	2,26
SEER	(2)(E)		4,25	4,16	4,28	4,34	4,10	4,12
Water flow	(1)	l/h	33965	37745	43948	47875	54311	58055
Water pressure drop	(1)(E)	kPa	37	38	38	39	40	41
Available pressure head - LP pumps	(1)	kPa	163	192	185	171	166	147
Maximum current absorption		A	167	190	215	229	242	290
Start up current		A	318	382	398	464	472	487
Startup current with soft starter		A	256	317	333	381	389	430
Compressors / circuits			4 / 2					
Expansion vessel volume		dm ³	24	24	24	24	24	24
Buffer tank volume		dm ³	600	600	765	765	765	765
Sound power level	(3)(E)	dB(A)	85	85	87	87	87	88
Transport weight unit with pump and tank		kg	1726	1869	2129	2161	2196	2196
Operating weight unit with pump and full tank		kg	2326	2469	2894	2926	2961	2961

(1) Outdoor air temperature 35°C, water temperature 12°C / 7°C (EN14511:2022)

(2) η efficiency values for heating and cooling are respectively calculated by the following formulas: $[\eta = SCOP / 2,5 - F(1) - F(2)]$ e $[\eta = SEER / 2,5 - F(1) - F(2)]$. For further information, please refer to the technical document "ErP 2009/125/EC DIRECTIVE" in the catalogue introducing pages, or to the EN14825:2022 regulation.

(3) Sound power level measured according to ISO 9614

(E) EUROVENT certified data

Air chillers and heat pumps LCX

LCX HS HEAT PUMPS RATED TECHNICAL DATA

LCX HL			062	072	082	092	094	102	104	
Power supply		V-ph-Hz	400 - 3N - 50							
Cooling capacity	(1)(E)	kW	57,3	65,6	77,6	87,4	89,0	101	103	
Total power input	(1)(E)	kW	20,3	22,9	26,5	31,1	31,5	35,2	36,1	
EER	(1)(E)		2,82	2,86	2,93	2,81	2,83	2,85	2,86	
SEER	(2)(E)		4,09	4,35	4,60	4,37	4,13	4,62	4,42	
Water flow	(1)	l/h	9856	11285	13358	15029	15313	17286	17778	
Water pressure drop	(1)(E)	kPa	25	24	26	25	25	29	29	
Available pressure head - LP pumps	(1)	kPa	143	139	136	134	133	127	130	
Heating capacity	(3)(E)	kW	66,5	76,1	87,8	103	105	113	117	
Total power input	(3)(E)	kW	19,0	21,3	24,8	28,7	29,7	32,2	33,8	
COP	(3)(E)		3,50	3,57	3,53	3,58	3,53	3,49	3,48	
SCOP	(2)(E)		4,17	4,38	4,38	4,36	4,13	4,03	4,19	
Heating energy efficiency class	(4)(E)		A++							
Water flow	(3)	l/h	11534	13190	15218	17819	18200	19506	20336	
Water pressure drop	(3)(E)	kPa	33	33	33	35	36	37	37	
Available pressure head - LP pumps	(3)	kPa	137	133	128	126	124	117	120	
Maximum current absorption		A	51,0	55,0	66,0	77,0	81,0	86,0	87,0	
Start up current		A	185	183	191	246	194	254	198	
Startup current with soft starter		A	111	124	139	184	122	192	137	
Compressors / circuits			2 / 1	2 / 1	2 / 1	2 / 1	4 / 2	2 / 1	4 / 2	
Expansion vessel volume		dm ³	12	12	12	12	12	12	12	
Buffer tank volume		dm ³	220	220	220	340	340	340	340	
Sound power level	(5)(E)	dB(A)	80	80	80	81	80	81	80	
Transport weight unit with pump and tank		kg	762	767	847	1086	1217	1096	1217	
Operating weight unit with pump and full tank		kg	982	987	1067	1426	1557	1436	1557	

LCX HL			122	124	142	144	162	164	194	
Power supply		V-ph-Hz	400 - 3N - 50							
Cooling capacity	(1)(E)	kW	112	115	126	133	158	150	176	
Total power input	(1)(E)	kW	40,6	41,1	47,1	47,0	59,6	56,4	63,6	
EER	(1)(E)		2,75	2,81	2,68	2,82	2,65	2,67	2,77	
SEER	(2)(E)		3,80	3,61	3,79	3,88	4,12	3,88	3,66	
Water flow	(1)	l/h	19202	19842	21739	22795	27214	25881	30277	
Water pressure drop	(1)(E)	kPa	27	27	29	29	34	32	33	
Available pressure head - LP pumps	(1)	kPa	118	116	172	169	154	157	157	
Heating capacity	(3)(E)	kW	135	139	147	154	182	173	206	
Total power input	(3)(E)	kW	38,0	39,4	45,1	43,7	53,0	53,8	59,9	
COP	(3)(E)		3,56	3,52	3,27	3,52	3,43	3,22	3,44	
SCOP	(2)(E)		4,38	4,22	3,95	3,74	3,77	3,91	3,81	
Heating energy efficiency class	(4)(E)		A++	A++	A++	A+	A+	A++	A++	
Water flow	(3)	l/h	23409	24033	25547	26722	31536	30016	35733	
Water pressure drop	(3)(E)	kPa	40	40	40	40	46	43	46	
Available pressure head - LP pumps	(3)	kPa	112	110	165	160	136	140	130	
Maximum current absorption		A	95,0	96,0	106	105	120	126	148	
Start up current		A	295	220	306	222	371	241	307	
Startup current with soft starter		A	230	146	241	163	288	189	245	
Compressors / circuits			2 / 1	4 / 2	2 / 1	4 / 2	2 / 1	4 / 2	4 / 2	
Expansion vessel volume		dm ³	24	24	24	24	24	24	24	
Buffer tank volume		dm ³	600	600	600	600	600	600	600	
Sound power level	(5)(E)	dB(A)	83	80	84	80	84	80	85	
Transport weight unit with pump and tank		kg	1440	1455	1490	1470	1510	1620	1676	
Operating weight unit with pump and full tank		kg	2040	2055	2090	2070	2110	2220	2276	

(1) Outdoor air temperature 35°C, water temperature 12°C / 7°C (EN14511:2022)

(2) η efficiency values for heating and cooling are respectively calculated by the following formulas: $[\eta = SCOP / 2,5 - F(1) - F(2)]$ e $[\eta = SEER / 2,5 - F(1) - F(2)]$. For further information, please refer to the technical document "ErP 2009/125/EC DIRECTIVE" in the catalogue introducing pages, or to the EN14825:2022 regulation.

(3) Outdoor air temperature dry bulb 7°C / wet bulb 6°C, water temperature 40°C / 45°C (EN14511:2022)

(4) Seasonal energy efficiency class for LOW TEMPERATURE room heating under AVERAGE climatic conditions [EUROPEAN REGULATION No 811/2013. The energy efficiency class of this product is included in the range A+++ → D]

(5) Sound power level measured according to ISO 9614

(E) EUROVENT certified data

LCX HS HEAT PUMPS RATED TECHNICAL DATA

LCX HL			214	244	274	294	324
Power supply		V-ph-Hz	400 - 3N - 50				
Cooling capacity	(1)(E)	kW	195	216	253	275	312
Total power input	(1)(E)	kW	75,2	84,8	90,8	108	123
EER	(1)(E)		2,59	2,55	2,78	2,55	2,54
SEER	(2)(E)		3,89	3,68	3,86	3,82	3,89
Water flow	(1)	l/h	33537	37139	43430	47237	53602
Water pressure drop	(1)(E)	kPa	34	33	36	34	37
Available pressure head - LP pumps	(1)	kPa	166	197	186	175	168
Heating capacity	(3)(E)	kW	233	265	295	330	366
Total power input	(3)(E)	kW	67,3	76,9	86,2	97,5	109
COP	(3)(E)		3,46	3,44	3,42	3,39	3,36
SCOP	(2)(E)		3,80	3,97	3,79	3,82	3,92
Heating energy efficiency class	(4)(E)		A++	A++	A+	A++	A++
Water flow	(3)	l/h	40476	45910	51192	57334	63554
Water pressure drop	(3)(E)	kPa	49	50	50	50	51
Available pressure head - LP pumps	(3)	kPa	137	176	164	151	139
Maximum current absorption		A	167	190	215	229	242
Start up current		A	318	382	398	464	472
Startup current with soft starter		A	256	317	333	381	389
Compressors / circuits			4 / 2				
Expansion vessel volume		dm ³	24	24	24	24	24
Buffer tank volume		dm ³	600	600	765	765	765
Sound power level	(5)(E)	dB(A)	85	85	87	87	88
Transport weight unit with pump and tank		kg	1726	1869	2129	2161	2196
Operating weight unit with pump and full tank		kg	2326	2469	2894	2926	2961

(1) Outdoor air temperature 35°C, water temperature 12°C / 7°C (EN14511:2022)

(2) η efficiency values for heating and cooling are respectively calculated by the following formulas: $[\eta = SCOP / 2,5 - F(1) - F(2)]$ e $[\eta = SEER / 2,5 - F(1) - F(2)]$. For further information, please refer to the technical document "ErP 2009/125/EC DIRECTIVE" in the catalogue introducing pages, or to the EN14825:2022 regulation.

(3) Outdoor air temperature dry bulb 7°C / wet bulb 6°C, water temperature 40°C / 45°C (EN14511:2022)

(4) Seasonal energy efficiency class for LOW TEMPERATURE room heating under AVERAGE climatic conditions [EUROPEAN REGULATION No 811/2013. The energy efficiency class of this product is included in the range A+++ → D]

(5) Sound power level measured according to ISO 9614

(E) EUROVENT certified data

DIMENSIONAL DRAWINGS

LCX FRAME 2

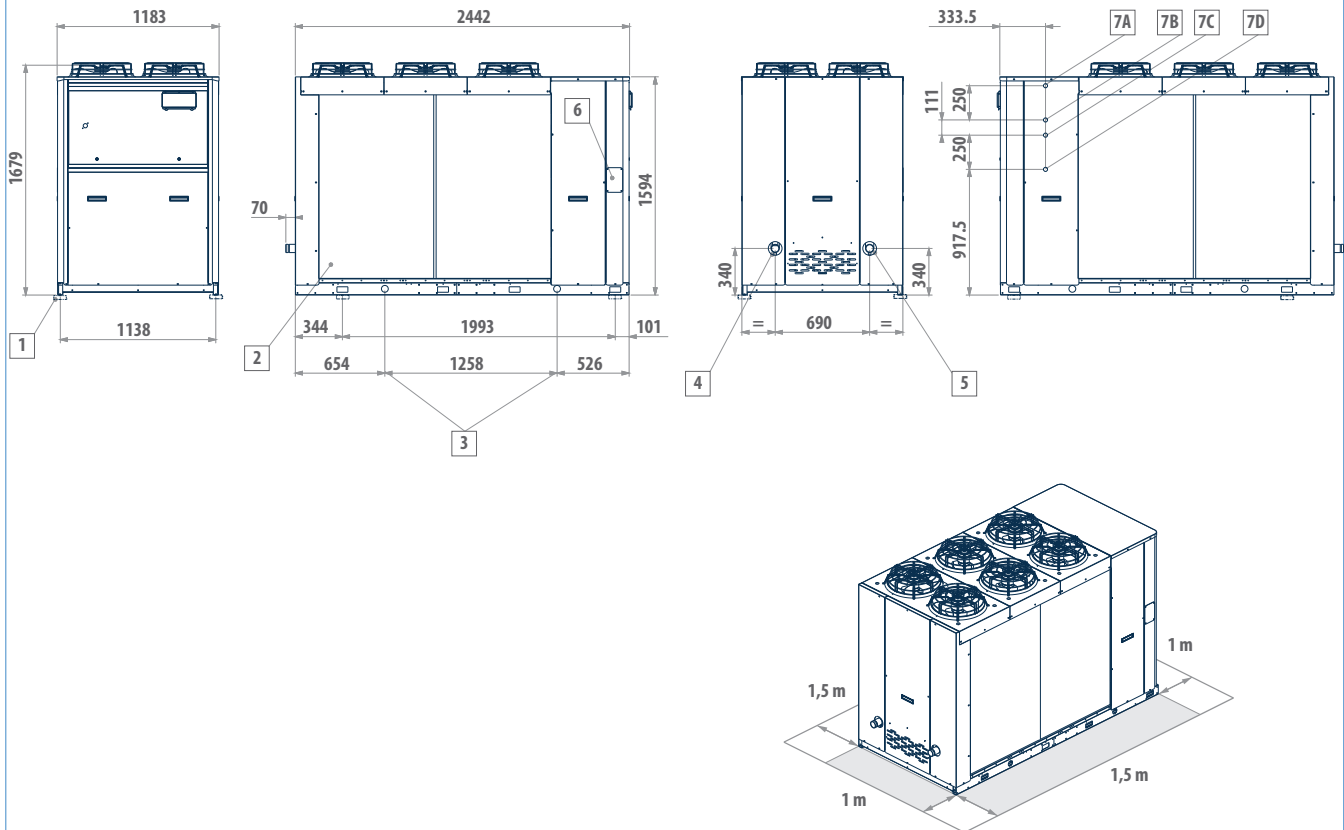

LEGEND

1	Vibration dampers
2	Protection grill (optional)
3	Lifting points
4	Water inlet (Victaulic 2")
5	Water outlet (Victaulic 2")
6	Power supply input
7A	Heat recovery water outlet (1"), left-hand circuit
7B	Heat recovery water inlet (1"), left-hand circuit
7C	Heat recovery water outlet (1"), right-hand circuit
7D	Heat recovery water inlet (1"), right-hand circuit

MODEL VERSION FRAME

MODEL	VERSION FRAME
	2
LCX 62	L - Q
LCX 72	L - Q
LCX 82	L - Q
LCX 92	S
LCX 102	S

DIMENSIONAL DRAWINGS

LCX FRAME 3

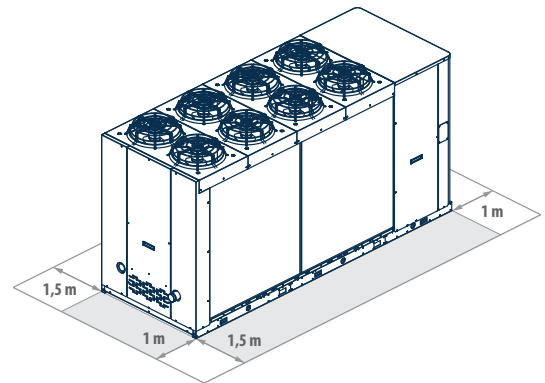
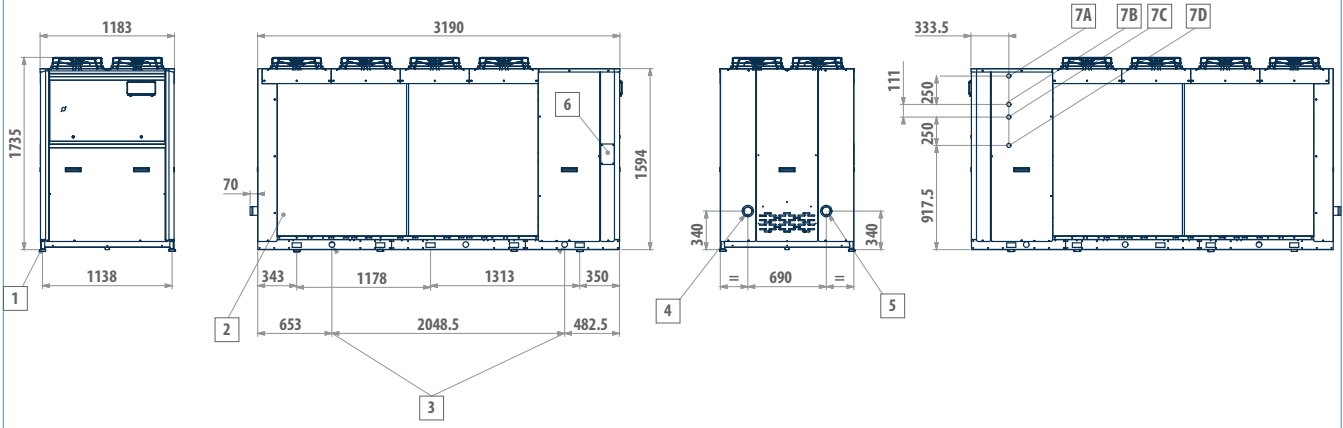

LEGEND

1	Vibration dampers
2	Protection grill (optional)
3	Lifting points
4	Water inlet (Victaulic 2 1/2")
5	Water outlet (Victaulic 2 1/2")
6	Power supply input
7A	Heat recovery water outlet (1"), left-hand circuit
7B	Heat recovery water inlet (1"), left-hand circuit
7C	Heat recovery water outlet (1"), right-hand circuit
7D	Heat recovery water inlet (1"), right-hand circuit

MODEL	VERSION FRAME 3
LCX 92	L - Q
LCX 102	L - Q
LCX 122	S
LCX 142	S
LCX 162	S

DIMENSIONAL DRAWINGS

LCX FRAME 3+

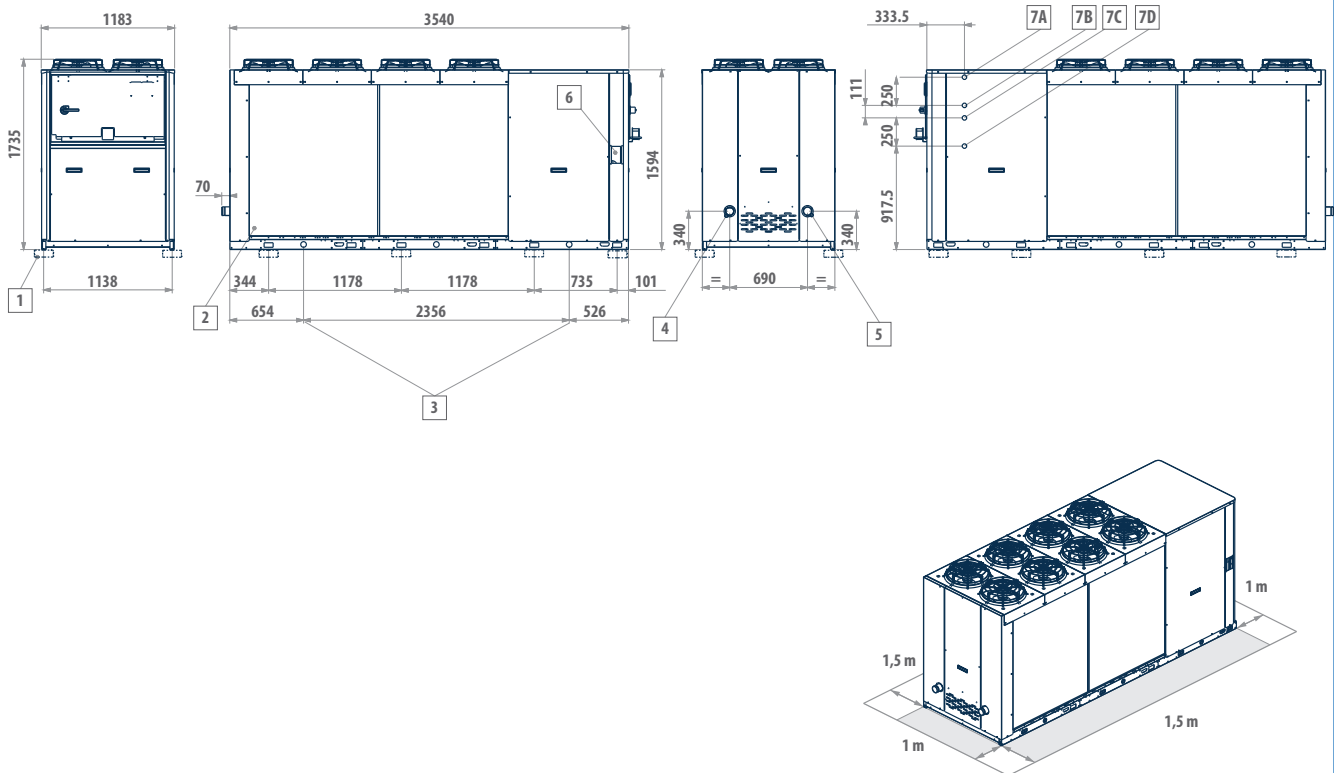

LEGEND

1	Vibration dampers
2	Protection grill (optional)
3	Lifting points
4	Water inlet (Victaulic 2 1/2")
5	Water outlet (Victaulic 2 1/2")
6	Power supply input
7A	Heat recovery water outlet (1"), left-hand circuit
7B	Heat recovery water inlet (1"), left-hand circuit
7C	Heat recovery water outlet (1"), right-hand circuit
7D	Heat recovery water inlet (1"), right-hand circuit

MODEL VERSION FRAME

MODEL	VERSION FRAME
	3+
LCX 94	L - Q
LCX 104	L - Q
LCX 124	S
LCX 144	S
LCX 164	S

DIMENSIONAL DRAWINGS

LCX FRAME 4

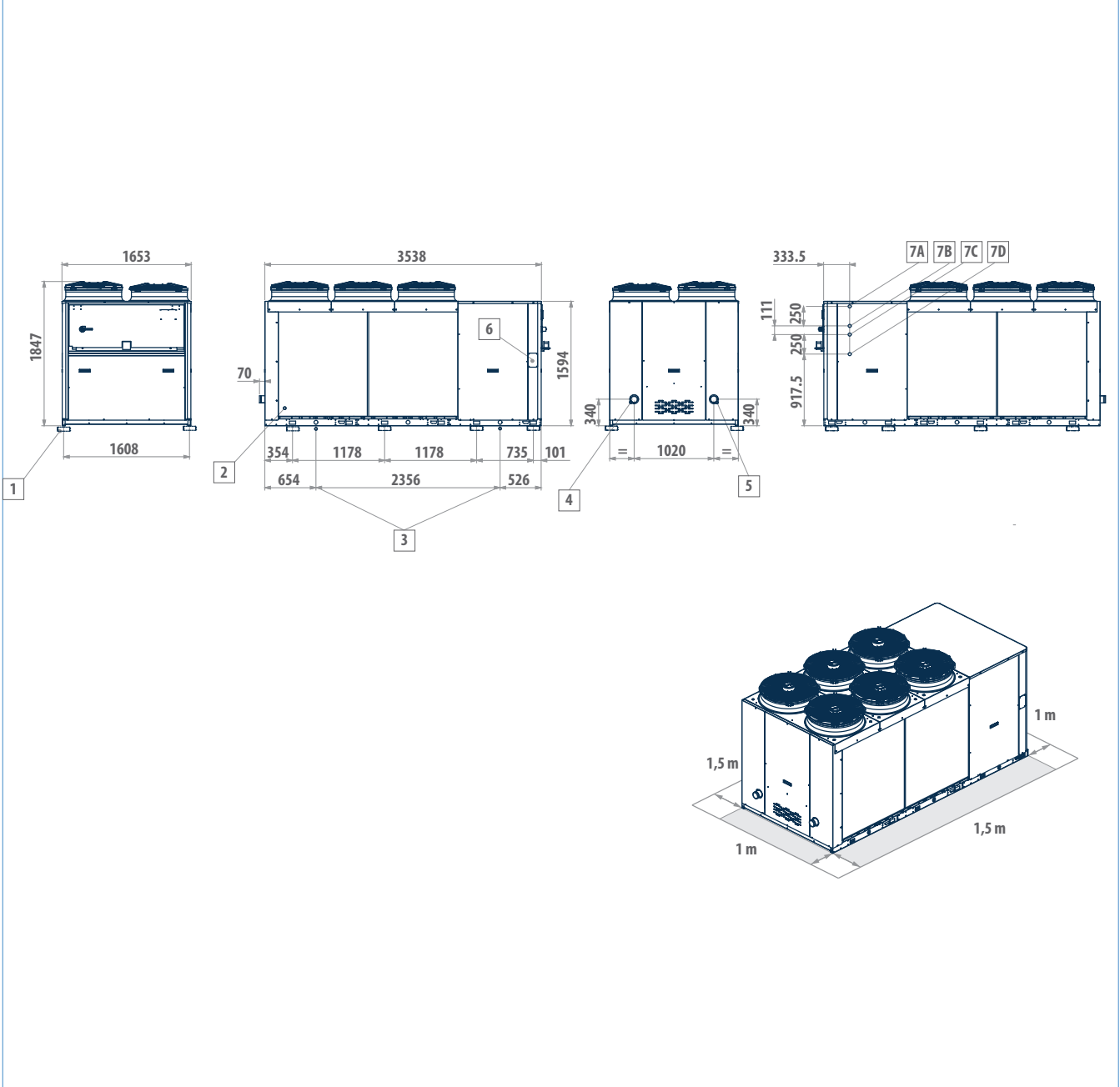

LEGEND

1	Vibration dampers
2	Protection grill (optional)
3	Lifting points (optional)
4	Water inlet (Victaulic 3")
5	Water outlet (Victaulic 3")
6	Power supply input
7A	Heat recovery water outlet (1"), left-hand circuit
7B	Heat recovery water inlet (1"), left-hand circuit
7C	Heat recovery water outlet (1"), right-hand circuit
7D	Heat recovery water inlet (1"), right-hand circuit
*	With EC=1884 fans

MODEL	VERSION FRAME 4
LCX 122	L - Q
LCX 124	L - Q
LCX 142	L - Q
LCX 144	L - Q
LCX 162	L - Q
LCX 164	L - Q
LCX 174	S
LCX 194	S - L - Q
LCX 214	S

Air chillers and heat pumps LCX

DIMENSIONAL DRAWINGS

LCX FRAME 5

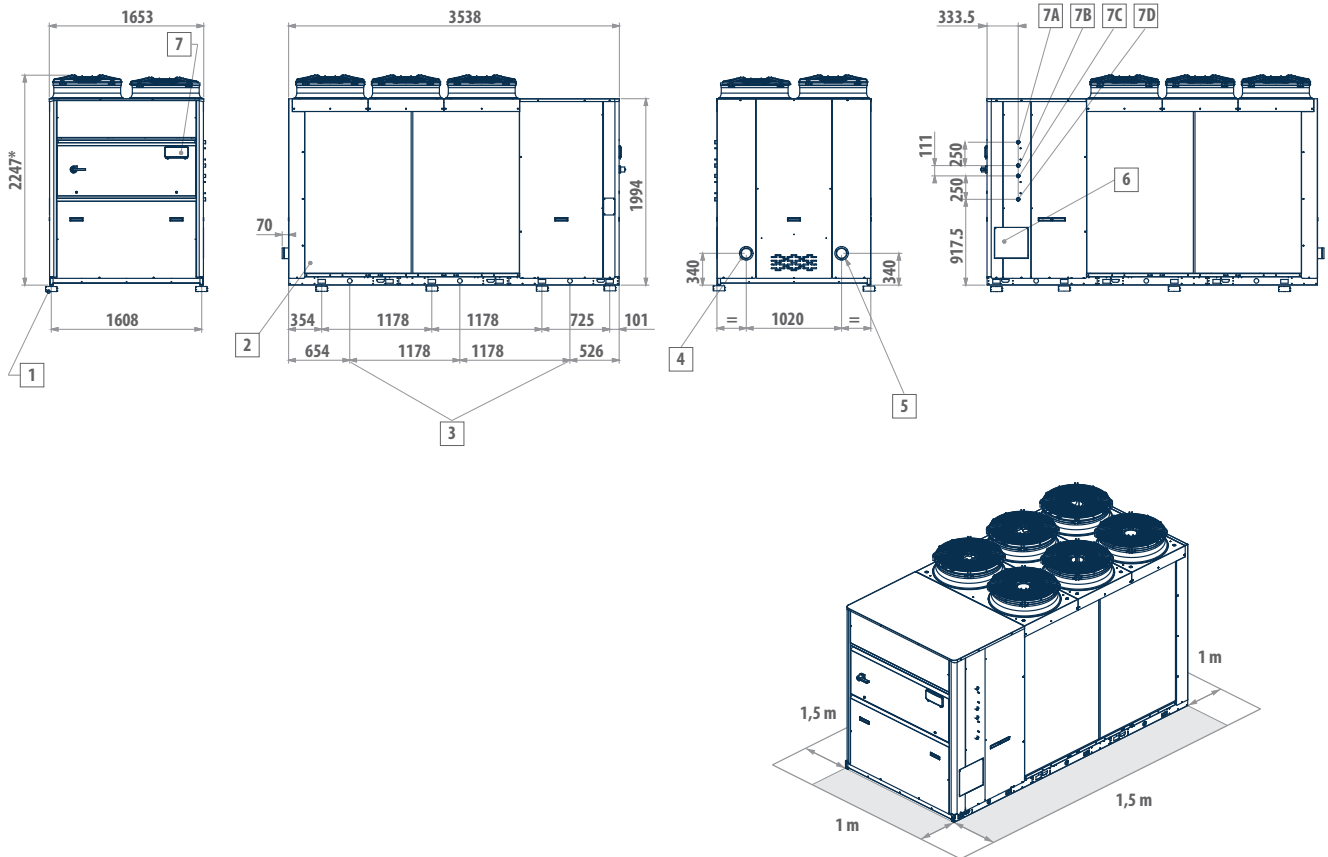

LEGEND

1	Vibration dampers
2	Protection grill (optional)
3	Lifting points (optional)
4	Water inlet (Victaulic 4")
5	Water outlet (Victaulic 4")
6	Power supply input
7A	Heat recovery water outlet (1"), left-hand circuit
7B	Heat recovery water inlet (1"), left-hand circuit
7C	Heat recovery water outlet (1"), right-hand circuit
7D	Heat recovery water inlet (1"), right-hand circuit
*	With EC=2284 fans

MODEL VERSION FRAME
5

LCX 214 L - Q

LCX 244 S - L - Q

DIMENSIONAL DRAWINGS

LCX FRAME 6

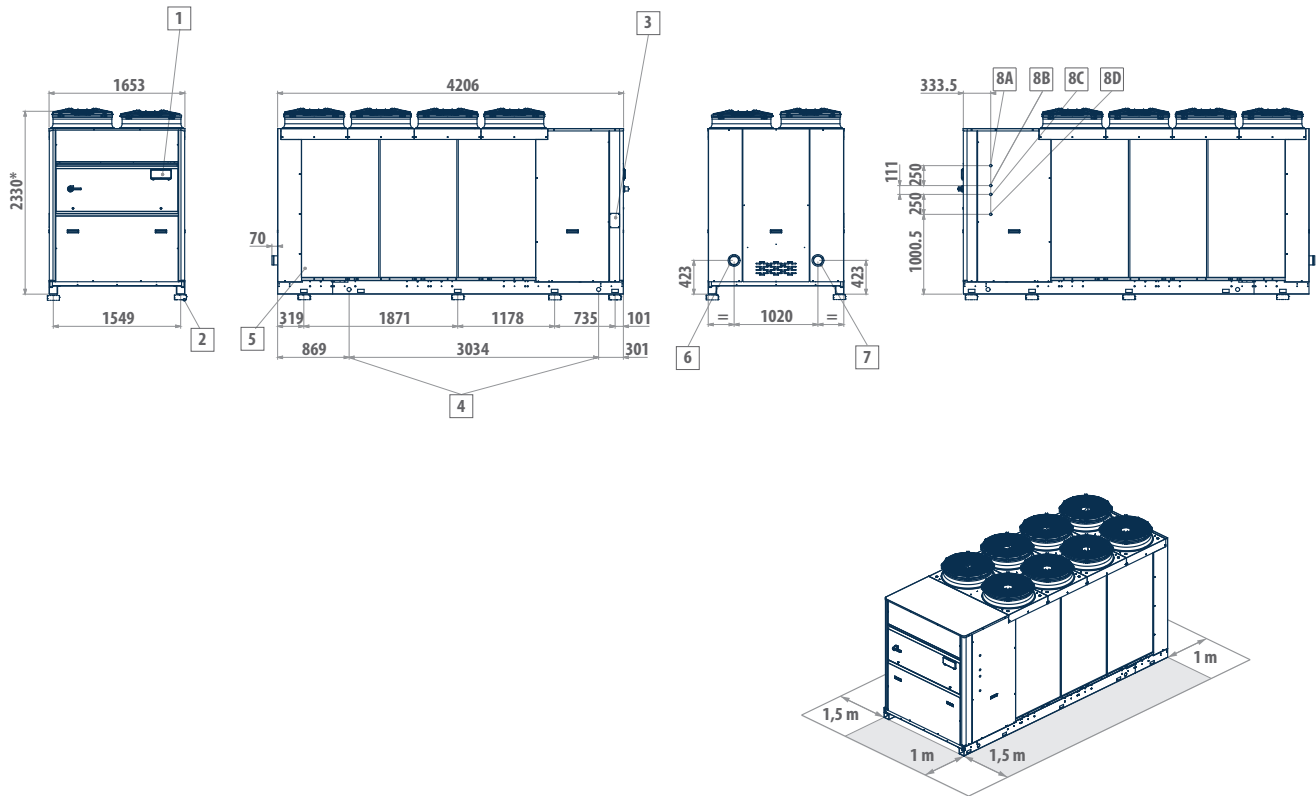

LEGEND

1	User interface
2	Vibration dampers
3	Power supply
4	Lifting points (optional)
5	Protection grill (optional)
6	Water inlet (Victaulic 4")
7	Water outlet (Victaulic 4")
8A	Heat recovery water outlet (1") left-hand circuit
8B	Heat recovery water inlet (1") left-hand circuit
8C	Heat recovery water outlet (1") right-hand circuit
8D	Heat recovery water inlet (1") right-hand circuit
*	With EC=2367 fans

MODEL VERSION FRAME 6

LCX 274	S - L - Q
LCX 294	S - L - Q
LCX 324	S - L - Q
LCX 364	S - L

VLS Chillers and HP with Low GWP refrigerant



Outdoor packaged unit

VLS 160 - 590 kW



R-454B
refrigerant



Plate
exchanger



Piping shell
and tube heat
exchanger



Axial fan



Scroll
compressor



Cooling only



Heating/
Cooling

PLUS

- » Refrigerant with GWP of less than 500
- » Available version with R410A refrigerant (VRS)
- » High seasonal efficiency values
- » Electronic expansion valve
- » Up to 6 compressors
- » 1 or 2 cooling circuits
- » Remote connectivity with the most common protocols
- » Possibility to configure low-noise versions
- » Available version with shell and tube heat exchanger

VLS heat pumps and water chillers are designed for heating or cooling the water to be used in air-conditioning systems for residential, commercial, or industrial use.

The use of low-GWP refrigerant ensures compliance with the limits established by the F-GAS regulation regarding gases that potentially contribute to global warming (greenhouse gases).

Air-water unit with high seasonal efficiency and low-GWP refrigerant

VLS is Galletti's new range of air-cooled monobloc chillers and heat pumps for outdoor installation featuring R454B refrigerant. R454B is a next generation A2L refrigerant with a GWP of only 467, one of the lowest on the market. This GWP value ensures that the VLS range complies with the gradual reduction of greenhouse gas emissions required by the F-GAS regulation, down to the stricter limits foreseen for 2030.

The range consists of 12 models with cooling capacities ranging from 160 to 590 kW, available in cooling only or reversible heat pump versions. The range's main strength is its high seasonal efficiency, which is designed to permanently reduce annual energy consumption as well as meet the minimum efficiency requirements established by ErP 2021. In order to increase the efficiency at partial loads, all VLS models are provided with tandem or trio solutions (2 or 3 compressors on a single circuit) and equipped with electronic expansion valve as standard.

The use of top quality components at the cutting edge of technology in the cooling, hydraulic, and electrical systems makes VLS units chillers state of the art in terms of efficiency, reliability, and operating limits.

In fact, the ability to produce water from -10 °C to 56 °C and operate at full load with outdoor air temperatures from -15 °C to 46 °C is guaranteed. The range allows high configurability from an acoustic point of view, having a wide range of accessories designed to reduce noise emissions. It is also guaranteed the possibility of selecting the execution with shell and tube heat exchanger for all models above 200 kW. The advanced control, always present in the whole range, allows a continuous monitoring of the operating parameters, advanced adjustment logics, and connectivity.



CONFIGURATOR

The models are completely configurable by selecting the version and the options. To the right is shown an example of configuration.

Version	Field	1	2	3	4	5	6	7	8	9	10	11	12	13
VLS162HS0B		A	1	S	0	E	0	0	M	0	0	G	0	1

To verify the compatibility of the options, use the selection software or the price list.

AVAILABLE VERSIONS

Only cooling versions and plate heat exchanger

- VLS..CS0B** Power supply 400V-3N-50Hz
- VLS..CS2B** Power supply 400V-3N-50Hz + circuit breaker
- VLS..CS4B** Power supply 400V-3-50Hz
- VLS..CS5B** Power supply 400V-3-50Hz + circuit breaker

Only cooling versions and shell and tube heat exchanger

- VLS..CT0B** Power supply 400V-3N-50Hz
- VLS..CT2B** Power supply 400V-3N-50Hz + circuit breaker
- VLS..CT4B** Power supply 400V-3-50Hz
- VLS..CT5B** Power supply 400V-3-50Hz + circuit breaker

Reversible heat pump versions and plate heat exchanger

- VLS..HS0B** Power supply 400V-3N-50Hz
- VLS..HS2B** Power supply 400V-3N-50Hz + circuit breaker
- VLS..HS4B** Power supply 400V-3-50Hz
- VLS..HS5B** Power supply 400V-3-50Hz + circuit breaker

Reversible heat pump versions and shell and tube heat exchanger

- VLS..HT0B** Power supply 400V-3N-50Hz
- VLS..HT2B** Power supply 400V-3N-50Hz + circuit breaker
- VLS..HT4B** Power supply 400V-3-50Hz
- VLS..HT5B** Power supply 400V-3-50Hz + circuit breaker

CONFIGURATION OPTIONS

1 Expansion valve

- A Electronic

2 Water pump and accessories

- 0 Absent
- 1 LP pump
- 2 LP OR double pump
- 3 HP pump
- 4 HP OR double pump
- 5 LP pump with Viton seal
- 6 LP OR double pump with Viton seal
- 7 HP pump with Viton seal
- 8 HP OR double pump with Viton seal
- A LP inverter pump
- B LP OR inverter double pump
- C HP Inverter pump
- D HP OR inverter double pump
- E LP inverter pump with Viton seal
- F LP inverter double pump with Viton seal
- G HP inverter pump with Viton seal

3 Water buffer tank

- 0 Absent
- S Present

4 Partial heat recovery

- 0 Absent
- D Included with pump free contact

5 Air flow modulation

- A Condensation control with high-head EC fans
- C Condensation control by phase-cut fans
- E Condensation control with EC fans

6 Antifreezing kit

- 0 Absent
- E Evaporator
- P Evaporator, pump and expansion vessel
- S Evaporator, pump, expansion vessel and tank

7 Acoustic insulation and attenuation

- 0 Absent
- 3 Insulation with compressor box and insulating mat + compressor sound jackets
- 6 Insulation with compressor box and insulating mat + compressor sound jackets + low noise EC fans (option "E" required in field 5)

8 Refrigerant pipework accessories

- 0 Absent
- 1 Liquid separator at compressor intake (heat pump only). Mandatory on 456,546,576 models.
- 2 Liquid separator in compressor intake + liquid injection for operation limit extension (only for heat pumps)

9 Remote control / Serial communication

- 0 Absent
- 2 RS485 connection port (Modbus protocol or Carel)
- B BACNET IP/pCOWeb serial board
- G BACNET IP / pCOWeb serial board + supervision software
- S Remote simplified control panel
- X mProcess remote control panel

10 Special coils / Protective treatments

- 0 Copper-aluminium (heat pump only)
- C Cataphoresis treatment on fins and coil carpentry
- E Microchannel in Long Life Alloy (standard for chiller)
- I Hydrophilic (heat pump only)
- M Microchannel with E-coating (standard for chiller)
- P Pre-painted fins with polyester paint (only heat pump)
- R Copper-copper (heat pump only)

11 Anti vibration shock mounts

- 0 Absent
- G Made of rubber
- M With spring

12 Outdoor coil trace heater

- 0 Absent
- 1 Present (heat pump only)

13 Onboard controller

- 1 Advanced

14 Protections

- 0 Absent
- G Anti-intrusion grilles (not available if cfg 7 = 3 or 6)
- Z Refrigerant circuit paneling (not available if cfg 7 = 3 or 6)

15 Language

- I Italian
- S Spanish
- E English
- F French
- D German

ACCESSORIES

A	Outdoor finned coil heat exchanger protection filters	M	0-10 V signal for external user pump control (on-board pump excluded)
B	Not in use	N	Compressor tandem/trio isolation valves
C	Pair of couplings Victaulic	O	Not in use
D	ON/OFF status of the compressors	P	Y-shaped filter
E	Remote control for step capacity limit (advanced controller required)	Q	Night-time low-noise
F	Configurable digital alarm board (advanced controller required)	R	Enabling 2nd set-point / external alarm signaling via digital input
G	Soft starter	S	Hot-wire electronic flow switch
H	Power factor capacitors	T	Energy metering kit
I	Refrigerant leak sensors (mandatory if cfg 7 = 3 or 6 or cfg 14 = Z)	U	Covering panels V
L	Water pipes additional insulation	V	Set-point modification with 4-20mA signal

EXTENDED OPERATING RANGE

The generous sizing of the coils combined with innovative technological solutions makes it possible for VLS to operate in very different climat-ic environments. The operating range may vary depending on the model; always refer to the technical documentation for more information.

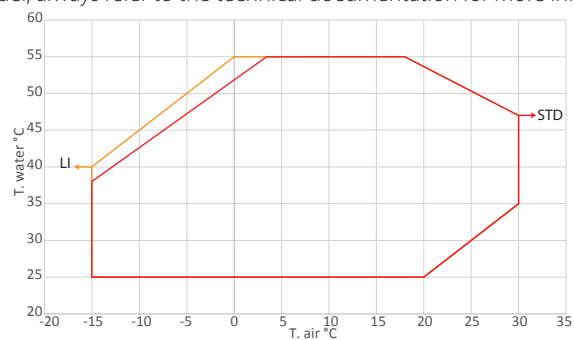
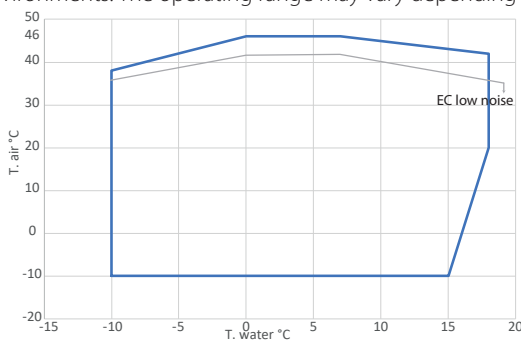

VLS Chillers and HP with Low GWP refrigerant

FUNCTIONS

Very low GWP refrigerant

Use of R454B refrigerant with low environmental impact. R454B is a next-generation A2L refrigerant with a GWP of only 467, one of the lowest on the market. This GWP value ensures that the VLS range complies with the gradual reduction of quotas of greenhouse refrigerants in the European market required by the F-GAS regulation, down to the stricter limits foreseen for 2030

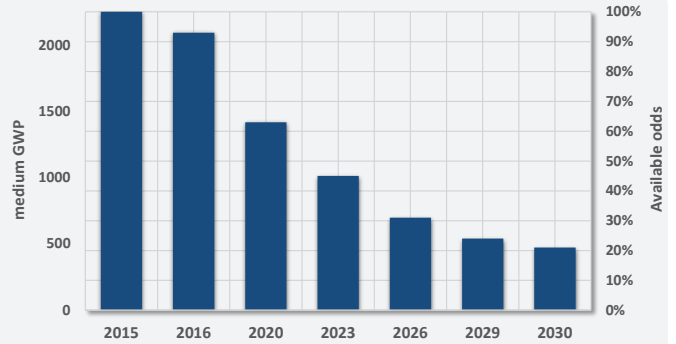

Scroll compressors

The scroll-type compressors designed to work with R454B, which can be sound insulated, include internal thermal protection of the windings and are installed on special anti-vibration supports. The scroll-type compressors are equipped with an IDV valve. The IDV intermediate delivery valve technology allows the compressor to avoid losses caused by overcompression and, consequently, the additional work the motor has to perform in partial-load operation, thus saving energy and improving seasonal and partial-load efficiency from 3% to 10%.



Liquid injection

Units can be supplied with a hot liquid by-pass to stabilise the discharge temperature of the compressor under the most critical operating conditions. Thanks to the injection of hot liquid at the evaporator outlet, it is possible to raise the evaporation pressure, thereby ensuring that the duty point remains within the compressor envelope even beyond conventional limits; in fact, hot water production up to 56°C is guaranteed.

To prevent liquid intake, this option includes a liquid/gas separator installed on the common branch before the tandem or trio compressor systems.

Microchannel

The entire Chiller range has microchannel coils as a standard feature. The large heat exchange surface, the absence of a copper-aluminum interface, and the perfect flow of air make it possible to achieve the same performance while reducing the refrigerant charge by up to 40%, with obvious benefits from an ecological point of view. Microchannel coils Galletti always feature surface treatment as a standard feature in order to provide maximum safety, even in harsh environments.

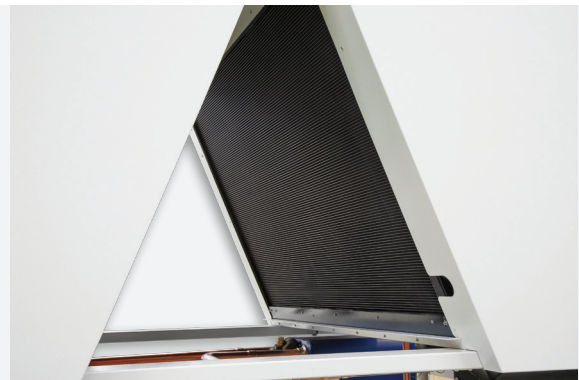

MAIN COMPONENTS

Structure

The range is designed modularly, replicating the optimized structure of V configuration condensing coils and fans. Its design ensures stability, sturdiness even during the most critical phases (such as transportation), and maximum accessibility to components in every VLS unit.



Electronic valve

It is standard on the entire range and offers greater responsiveness during transients. The electronics also manage the synergistic operation of the compressors and the valve, thereby making it possible to vary overheating and maximize efficiency at partial loads.



Safety procedures in case of refrigerant leakage

As an option feature, the units are equipped with leak detection sensors in the electrical control board and near the cooling circuit. The microprocessor manages the procedures for securing and shutting down the unit in case of refrigerant leakage, also making it possible to divert the power supply of the control unit that collects the information from the leak sensors on a low-voltage emergency line. This function allows the complete disconnection of the power to the unit during maintenance operations, while leaving all the safety systems enabled.

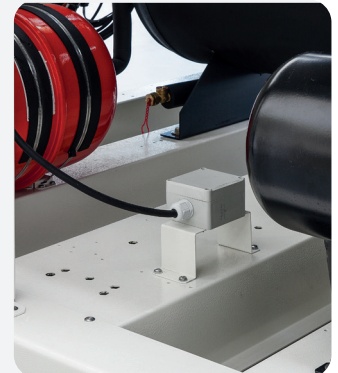

Economy - low noise function

Based on time slots or no-voltage contact, this function makes it possible to reduce the maximum speed of fans and the number of compressors that can be activated. This operation is especially useful during the night phase, when the power required is very low, and the unit can operate at a reduced level, thus lowering the noise level during a sensitive time period.

Low noise execution

The units can be supplied in a low-noise version, with silencing housings and reduced speed BLDC fans. This configuration, together with the night-time attenuation function, significantly reduces the sound power level.

Primary heat pump management

In case of a decoupled circuit, it is possible, via remote sensor, to switch off the primary circuit's pumps, when permitted, due to low thermal load. In this manner a further reduction in pumping costs is achieved.

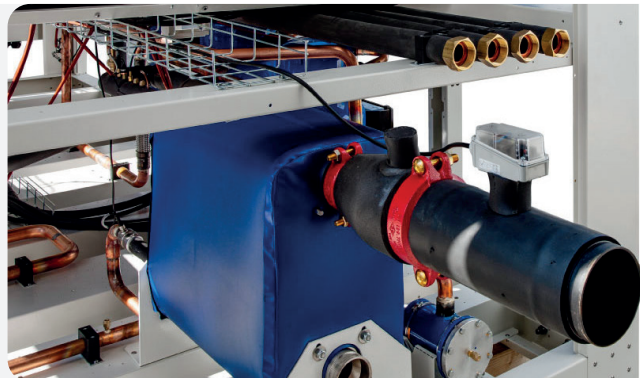

VLS Chillers and HP with Low GWP refrigerant

WATER CHILLERS RATED TECHNICAL DATA VLS C

VLS C			162	202	234	254	274	314
Power supply		V-ph-Hz	400-3N-50					
Cooling capacity	(1)(E)	kW	160	210	232	250	274	315
Total power input	(1)(E)	kW	58,3	67,3	73,9	85,0	102	116
EER	(1)(E)		2,75	3,12	3,14	2,94	2,69	2,71
SEER	(2)(E)		4,25	4,68	4,57	4,33	4,27	4,25
Water flow	(1)	l/h	27516	36134	39882	42982	47115	54152
Water pressure drop	(1)(E)	kPa	26	28	45	50	47	52
Available pressure head - LP pumps	(1)	kPa	118	150	120	107	99	83
Available pressure head - HP pumps	(1)	kPa	213	205	176	164	200	183
Maximum current absorption		A	123	156	176	192	214	244
Start up current		A	387	422	396	404	476	512
Startup current with soft starter		A	301	335	331	339	393	425
Compressors / circuits			2/1	2/1	4/2	4/2	4/2	4/2
Buffer tank volume		dm ³	180	350	350	350	350	350
Sound power level	(3)(E)	dB(A)	89	91	89	90	91	91
Sound power level, low-noise version	(3)	dB(A)	85	85	84	84	84	85
Sound power level quiet version	(3)	dB(A)	83	83	82	82	82	83
Weight without options		kg	1047	1744	1876	1783	1982	1994
Maximum transport weight		kg	1188	1915	2048	1984	2125	2137

VLS C			344	374	414	456	546	576
Power supply		V-ph-Hz	400-3N-50					
Cooling capacity	(1)(E)	kW	344	370	420	475	545	590
Total power input	(1)(E)	kW	118	125	126	162	179	201
EER	(1)(E)		2,92	2,96	3,33	2,93	3,04	2,94
SEER	(2)(E)		4,43	4,33	4,78	4,61	4,64	4,62
Water flow	(1)	l/h	59124	63602	72187	81639	93660	101397
Water pressure drop	(1)(E)	kPa	36	39	30	35	41	46
Available pressure head - LP pumps	(1)	kPa	123	116	155	133	157	130
Available pressure head - HP pumps	(1)	kPa	228	222	213	190	199	173
Maximum current absorption		A	263	278	312	362	415	460
Start up current		A	537	550	585	624	642	734
Startup current with soft starter		A	447	462	496	544	548	648
Compressors / circuits			4/2	4/2	4/2	6/2	6/2	6/2
Buffer tank volume		dm ³	550	550	700	700	850	850
Sound power level	(3)(E)	dB(A)	93	93	94	94	95	95
Sound power level, low-noise version	(3)	dB(A)	87	87	88	87	89	89
Sound power level quiet version	(3)	dB(A)	85	85	86	85	87	87
Weight without options		kg	2557	2563	3233	3499	4090	4144
Maximum transport weight		kg	2825	2832	3423	3689	4375	4429

(1) Outdoor air temperature 35°C, water temperature 12°C / 7°C (EN14511:2022)

(2) η efficiency values for heating and cooling are respectively calculated by the following formulas: $[\eta = SCOP / 2,5 - F(1) - F(2)]$ e $[\eta = SEER / 2,5 - F(1) - F(2)]$. For further information, please refer to the technical document "ErP 2009/125/EC DIRECTIVE" in the catalogue introducing pages, or to the EN14825:2022 regulation.

(3) Sound power level measured according to ISO 9614

(E) EUROVENT certified data

HEAT PUMPS RATED TECHNICAL DATA VLS H

VLS H			162	202	234	254	274	314
Power supply		V-ph-Hz	400-3N-50					
Cooling capacity	(1)(E)	kW	160	210	232	250	274	310
Total power input	(1)(E)	kW	58,5	67,7	73,9	85,0	102	116
EER	(1)(E)		2,73	3,10	3,14	2,94	2,69	2,67
SEER	(2)(E)		4,13	4,56	4,41	4,22	4,17	4,16
Water flow	(1)	l/h	27525	36122	39897	42992	47115	53291
Water pressure drop	(1)(E)	kPa	26	28	45	50	47	50
Available pressure head - LP pumps	(1)	kPa	117	151	121	108	99	82
Available pressure head - HP pumps	(1)	kPa	213	206	178	165	200	182
Heating capacity	(3)(E)	kW	167	224	256	264	290	330
Total power input	(3)(E)	kW	56,4	68,2	77,9	82,5	99,4	112
COP	(3)(E)		2,96	3,28	3,29	3,20	2,92	2,95
SCOP	(2)(E)		3,56	3,50	4,01	4,04	3,71	3,87
Heating energy efficiency class	(4)(E)		A+	A+	A++	A++	A+	A++
Water flow	(3)	l/h	28975	38872	44430	45822	50334	57286
Water pressure drop	(3)(E)	kPa	29	32	55	56	53	57
Available pressure head - LP pumps	(3)	kPa	98	139	108	91	78	54
Available pressure head - HP pumps	(3)	kPa	193	194	164	148	178	153
Maximum current absorption		A	123	156	176	192	214	244
Start up current		A	387	422	396	404	476	512
Startup current with soft starter		A	301	335	331	339	393	425
Compressors / circuits			2/1	2/1	4/2	4/2	4/2	4/2
Buffer tank volume		dm ³	180	350	350	350	350	350
Sound power level	(5)(E)	dB(A)	89	91	89	90	91	91
Sound power level, low-noise version	(5)	dB(A)	85	85	84	84	84	85
Sound power level quiet version	(5)	dB(A)	83	83	82	82	82	83
Weight without options		kg	1155	2040	2172	1969	2174	2188
Maximum transport weight		kg	1296	2241	2374	2149	2345	2360

(1) Outdoor air temperature 35°C, water temperature 12°C / 7°C (EN14511:2022)

(2) η efficiency values for heating and cooling are respectively calculated by the following formulas: [$\eta = SCOP / 2,5 - F(1) - F(2)$] e [$\eta = SEER / 2,5 - F(1) - F(2)$]. For further information, please refer to the technical document "ErP 2009/125/EC DIRECTIVE" in the catalogue introducing pages, or to the EN14825:2022 regulation.

(3) Outdoor air temperature dry bulb 7°C / wet bulb 6°C, water temperature 40°C / 45°C (EN14511:2022)

(4) Seasonal energy efficiency class for LOW TEMPERATURE room heating under AVERAGE climatic conditions [EUROPEAN REGULATION No 811/2013. The energy efficiency class of this product is included in the range A+++ → D]

(5) Sound power level measured according to ISO 9614

(E) EUROVENT certified data

VLS Chillers and HP with Low GWP refrigerant

HEAT PUMPS RATED TECHNICAL DATA VLS H

VLS H			344	374	414	456	546	576
Power supply		V-ph-Hz	400-3N-50					
Cooling capacity	(1)(E)	kW	343	366	418	472	543	585
Total power input	(1)(E)	kW	118	126	128	162	179	205
EER	(1)(E)		2,91	2,90	3,26	2,91	3,03	2,85
SEER	(2)(E)		4,35	4,23	4,69	4,60	4,61	4,60
Water flow	(1)	l/h	58960	62911	71831	81112	93327	100545
Water pressure drop	(1)(E)	kPa	36	38	30	35	41	45
Available pressure head - LP pumps	(1)	kPa	124	117	157	134	159	132
Available pressure head - HP pumps	(1)	kPa	229	223	214	191	201	175
Heating capacity	(3)(E)	kW	370	391	443	505	572	627
Total power input	(3)(E)	kW	115	125	129	164	178	196
COP	(3)(E)		3,21	3,13	3,42	3,08	3,21	3,20
SCOP	(2)(E)		3,68	3,72	3,65	3,42	3,65	3,80
Heating energy efficiency class	(4)(E)		A+					
Water flow	(3)	l/h	64235	67894	76926	87689	99325	108888
Water pressure drop	(3)(E)	kPa	42	44	34	40	46	52
Available pressure head - LP pumps	(3)	kPa	109	102	143	113	130	95
Available pressure head - HP pumps	(3)	kPa	214	207	200	168	172	138
Maximum current absorption		A	263	278	312	362	415	460
Start up current		A	537	550	585	624	642	734
Startup current with soft starter		A	447	462	496	544	548	648
Compressors / circuits			4/2	4/2	4/2	6/2	6/2	6/2
Buffer tank volume		dm ³	550	550	700	700	850	850
Sound power level	(5)(E)	dB(A)	93	93	94	94	95	95
Sound power level, low-noise version	(5)	dB(A)	87	87	88	87	89	89
Sound power level quiet version	(5)	dB(A)	85	85	86	85	87	87
Weight without options		kg	2869	2876	3623	3889	4641	4697
Maximum transport weight		kg	2909	2930	3813	4079	4926	4982

(1) Outdoor air temperature 35°C, water temperature 12°C / 7°C (EN14511:2022)

(2) η efficiency values for heating and cooling are respectively calculated by the following formulas: $[\eta = SCOP / 2,5 - F(1) - F(2)]$ e $[\eta = SEER / 2,5 - F(1) - F(2)]$. For further information, please refer to the technical document "ErP 2009/125/EC DIRECTIVE" in the catalogue introducing pages, or to the EN14825:2022 regulation.

(3) Outdoor air temperature dry bulb 7°C / wet bulb 6°C, water temperature 40°C / 45°C (EN14511:2022)

(4) Seasonal energy efficiency class for LOW TEMPERATURE room heating under AVERAGE climatic conditions [EUROPEAN REGULATION No 811/2013. The energy efficiency class of this product is included in the range A+++ → D]

(5) Sound power level measured according to ISO 9614

(E) EUROVENT certified data

DIMENSIONAL DRAWINGS

VLS 162 C

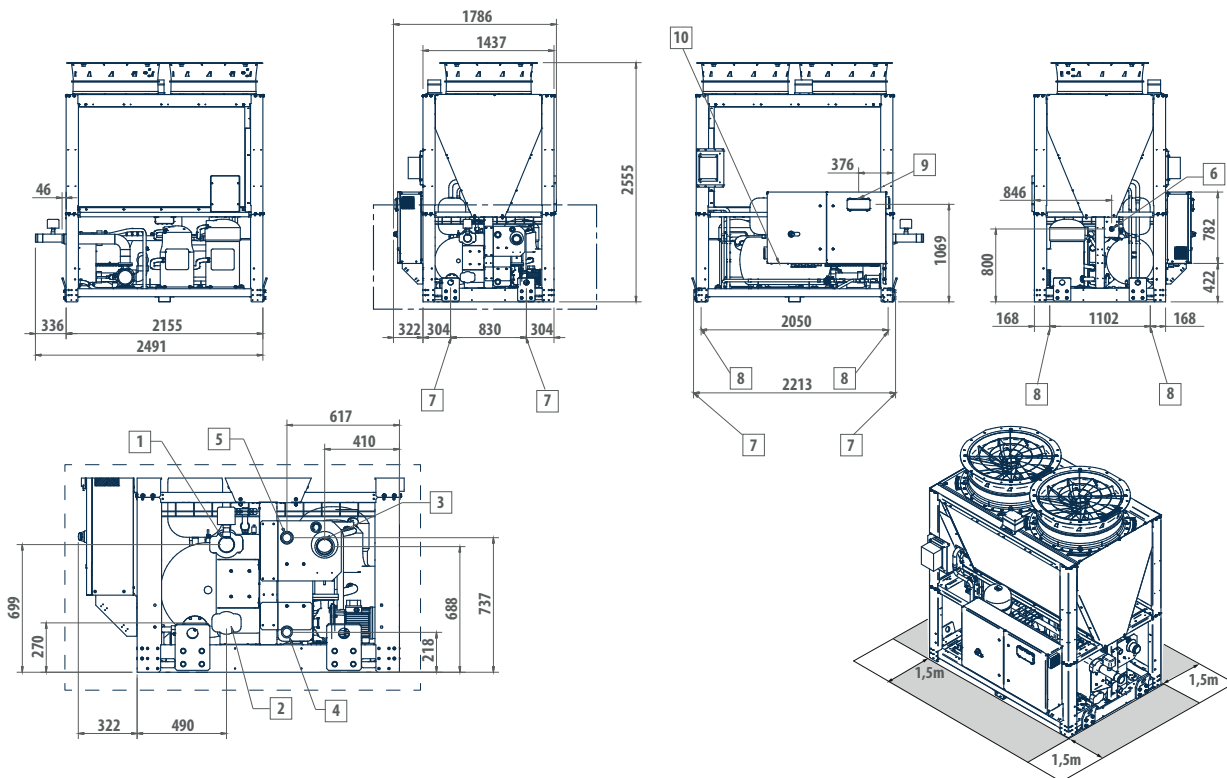

LEGEND

1	Water inlet Victaulic 3"
2	Water outlet, evaporator only Victaulic 3"
3	Water outlet pump and/or tank Victaulic 3"
4	Heat exchanger inlet 2" M
5	Heat exchanger outlet 2" M
6	Outlet safety valve 1" M
7	Lifting points
8	Vibration dumpers
9	User interface
10	Power supply input

VLS Chillers and HP with Low GWP refrigerant

DIMENSIONAL DRAWINGS

VLS 162 H

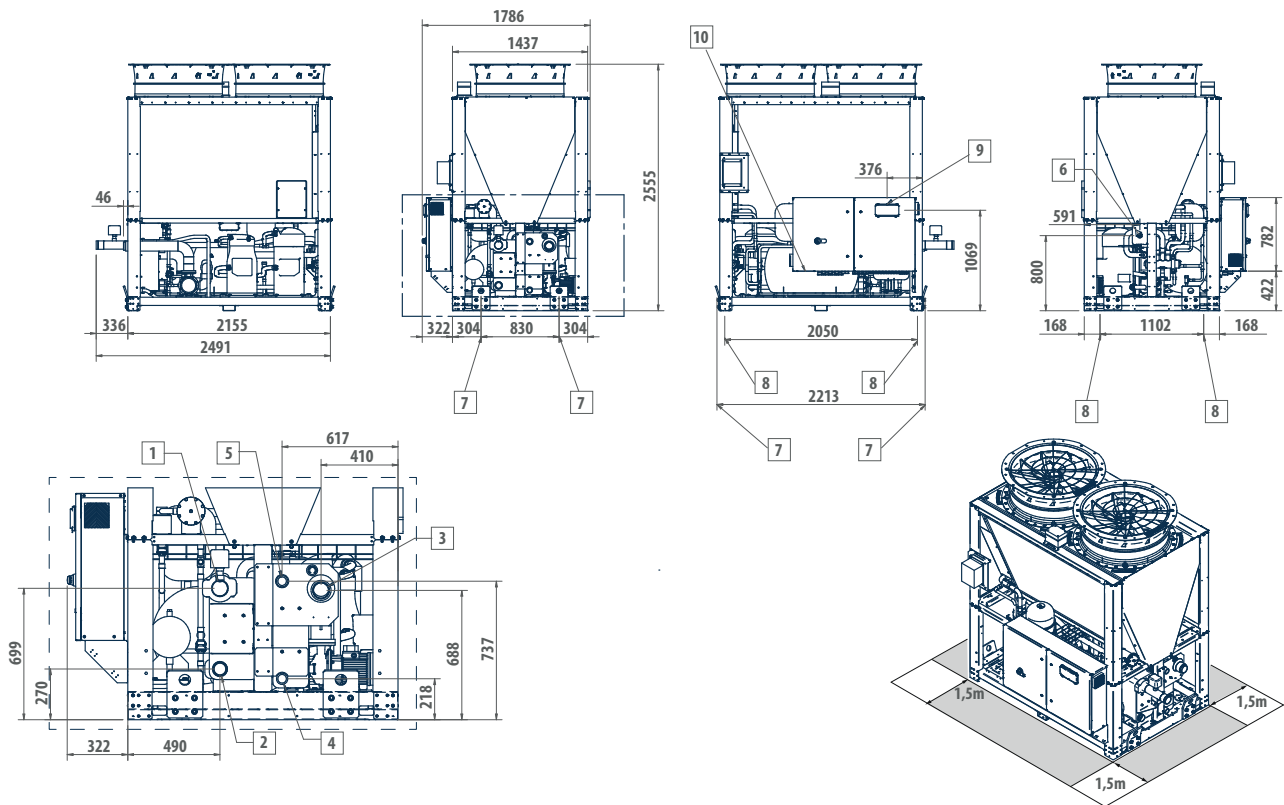

LEGEND

1	Water inlet Victaulic 3"
2	Water outlet, evaporator only Victaulic 3"
3	Water outlet pump and/or tank Victaulic 3"
4	Heat exchanger inlet 2" M
5	Heat exchanger outlet 2" M
6	Outlet safety valve 1" M
7	Lifting points
8	Vibration dumpers
9	User interface
10	Power supply input

DIMENSIONAL DRAWINGS

VLS C 202 mono circuit

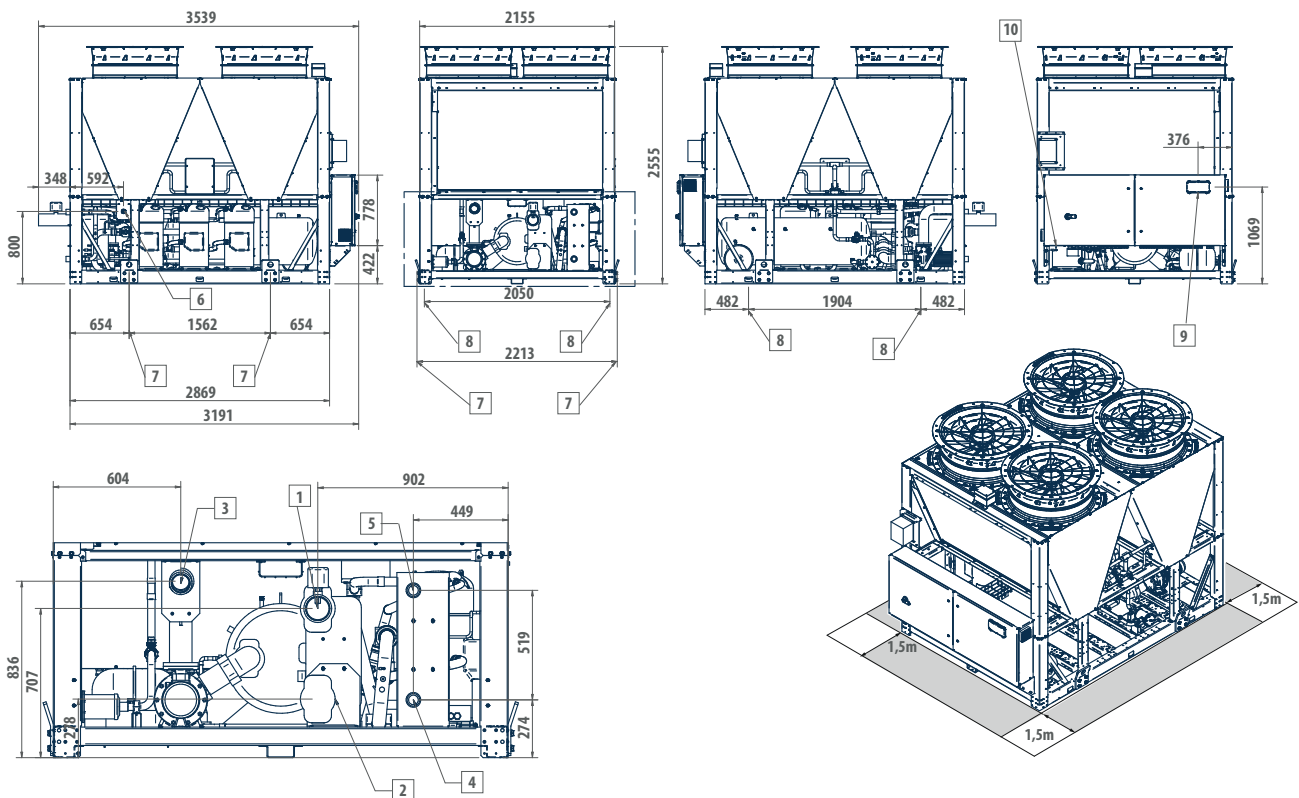

LEGEND

1	Water inlet Victaulic 4"
2	Water outlet, evaporator only Victaulic 4"
3	Water outlet pump and/or tank Victaulic 4"
4	Heat exchanger inlet 2" M
5	Heat exchanger outlet 2" M
6	Outlet safety valve 1" M
7	Lifting points
8	Vibration dumpers
9	User interface
10	Power supply input

VLS Chillers and HP with Low GWP refrigerant

DIMENSIONAL DRAWINGS

VLS H 202 mono circuit

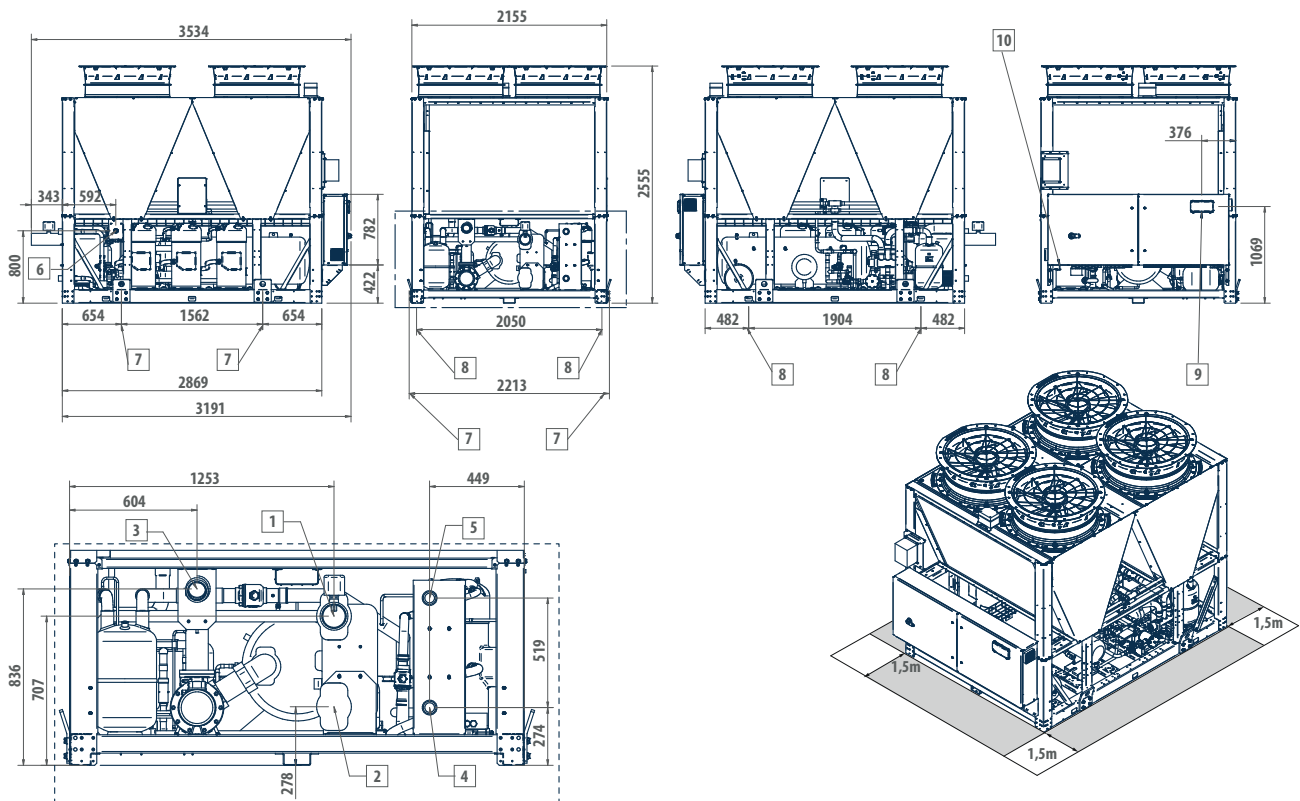

LEGEND

- | | |
|----|--|
| 1 | Water inlet Victaulic 4" |
| 2 | Water outlet, evaporator only Victaulic 4" |
| 3 | Water outlet pump and/or tank Victaulic 4" |
| 4 | Heat exchanger inlet 2" M |
| 5 | Heat exchanger outlet 2" M |
| 6 | Outlet safety valve 1" M |
| 7 | Lifting points |
| 8 | Vibration dumpers |
| 9 | User interface |
| 10 | Power supply input |

DIMENSIONAL DRAWINGS

VLS C 234; 254 - 314 double circuit

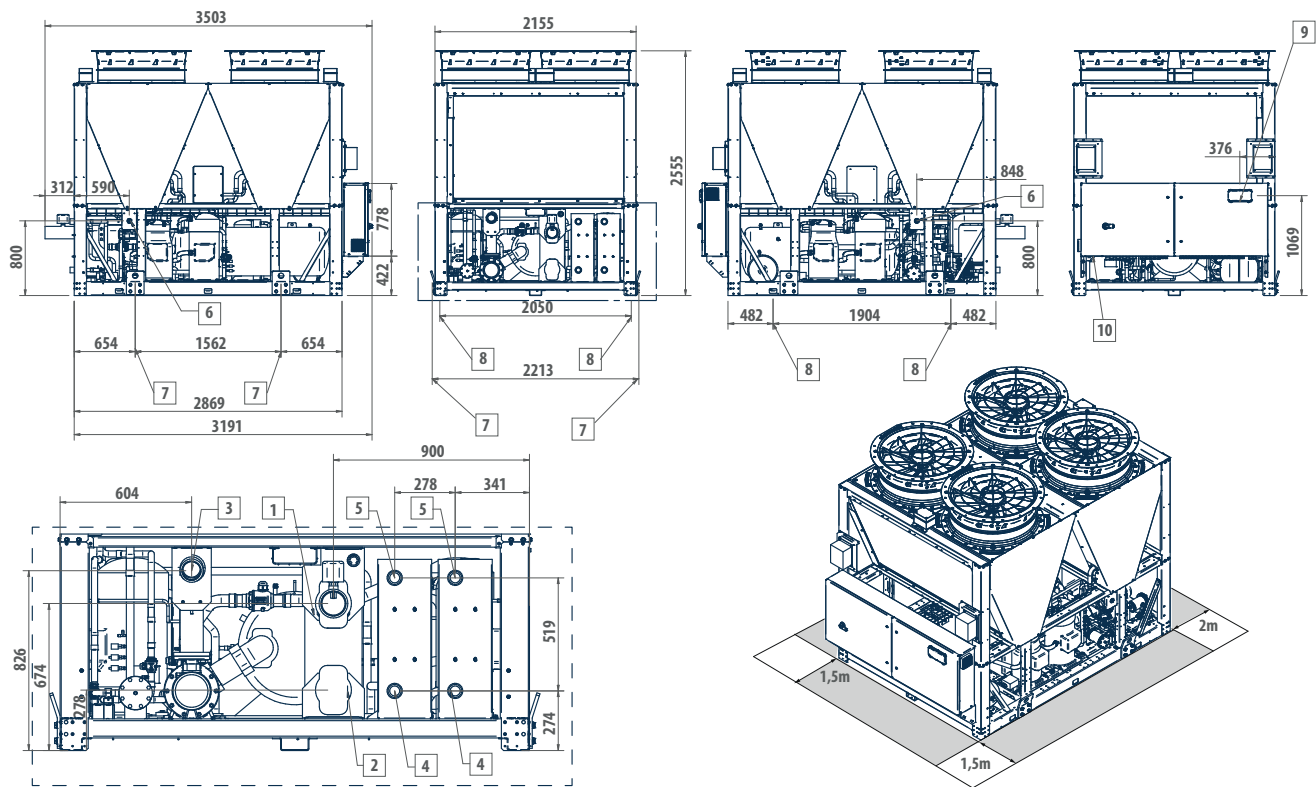

LEGEND

1	Water inlet Victaulic 4"
2	Water outlet, evaporator only Victaulic 4"
3	Water outlet pump and/or tank Victaulic 4"
4	Heat exchanger inlet 2" M
5	Heat exchanger outlet 2" M
6	Outlet safety valve 1" M
7	Lifting points
8	Vibration dumpers
9	User interface
10	Power supply input

VLS Chillers and HP with Low GWP refrigerant

DIMENSIONAL DRAWINGS

VLS H 234; 254 - 314 double circuit

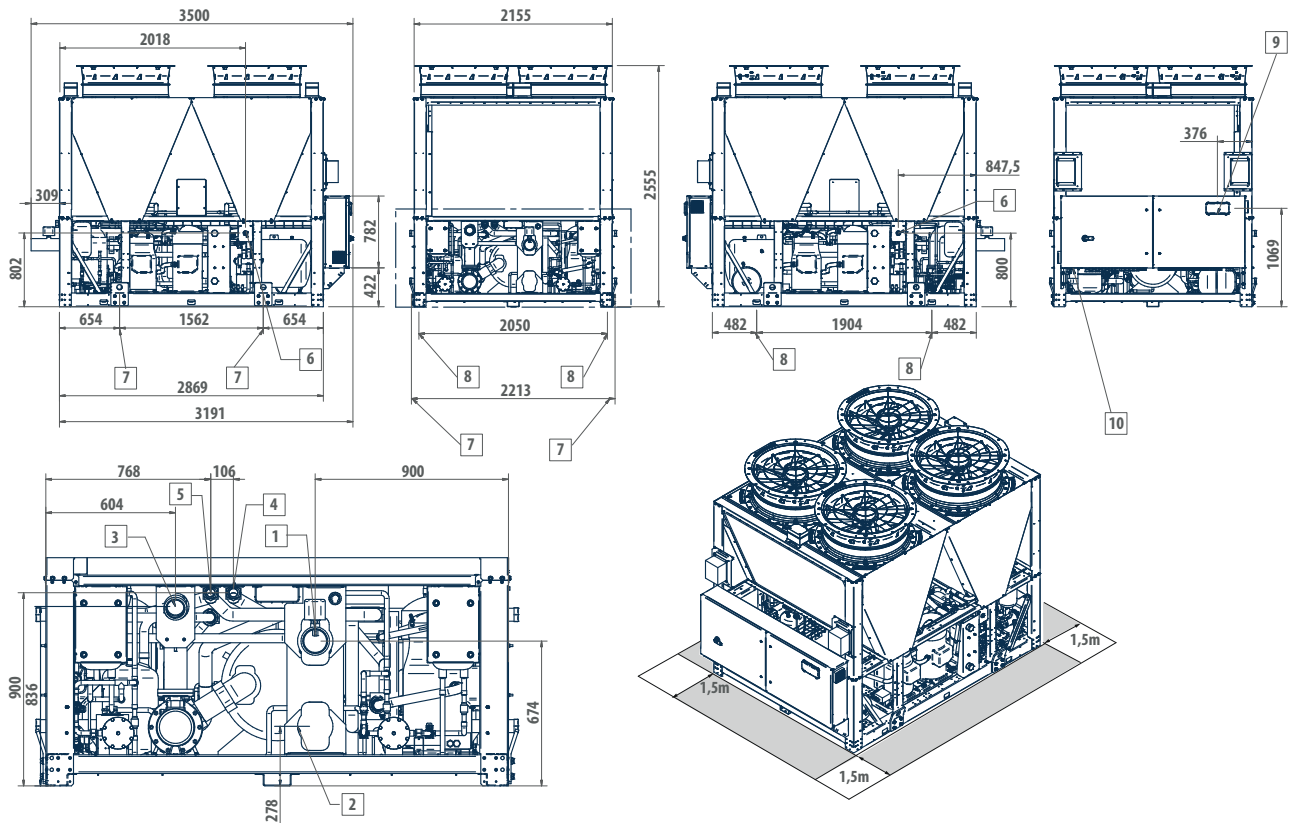

LEGEND

1	Water inlet Victaulic 4"
2	Water outlet, evaporator only Victaulic 4"
3	Water outlet pump and/or tank Victaulic 4"
4	Heat exchanger inlet 2" M
5	Heat exchanger outlet 2" M
6	Outlet safety valve 1" M
7	Lifting points
8	Vibration dumpers
9	User interface
10	Power supply input

DIMENSIONAL DRAWINGS

VLS C 344 - 374

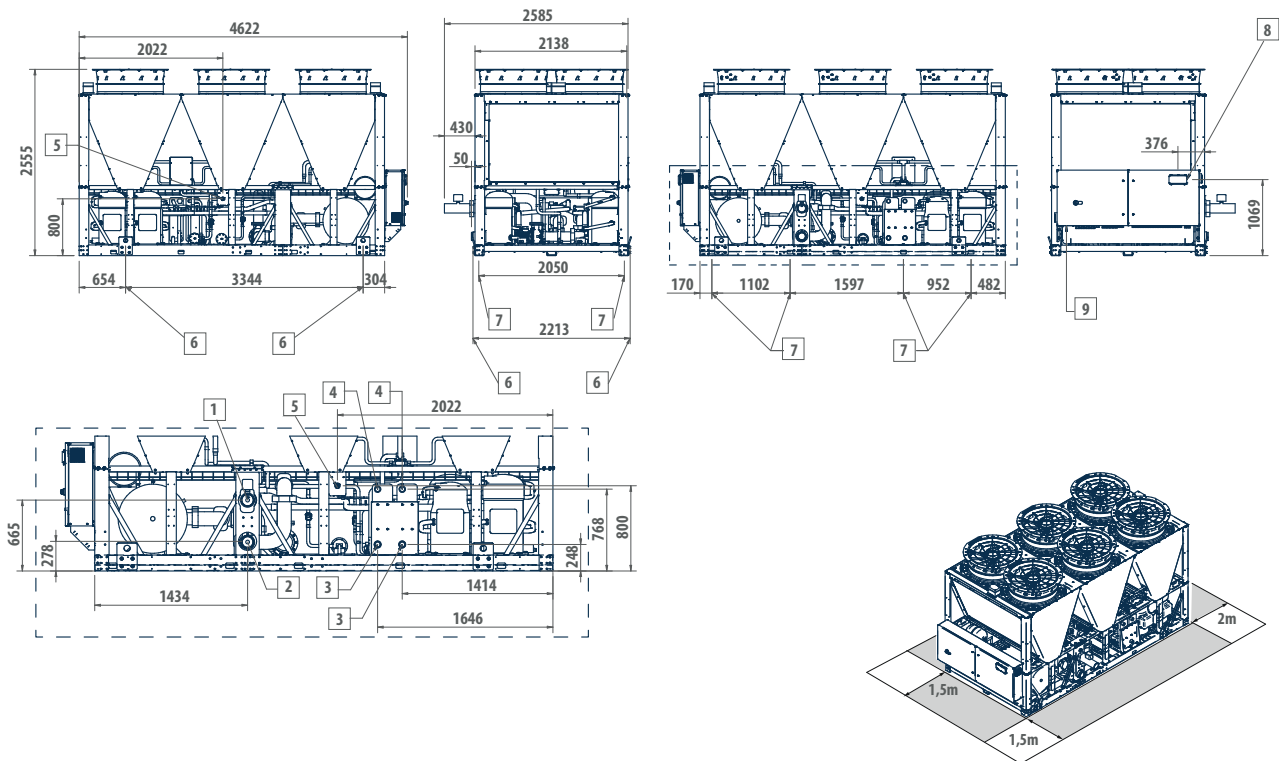

LEGEND

1	Water inlet Victaulic 4"
2	Water outlet Victaulic 4"
3	Heat exchanger inlet 2" M
4	Heat exchanger outlet 2" M
5	Outlet safety valve 1" M
6	Lifting points
7	Vibration dumpers
8	User interface
9	Power supply input

VLS Chillers and HP with Low GWP refrigerant

DIMENSIONAL DRAWINGS

VLS H 344 - 374

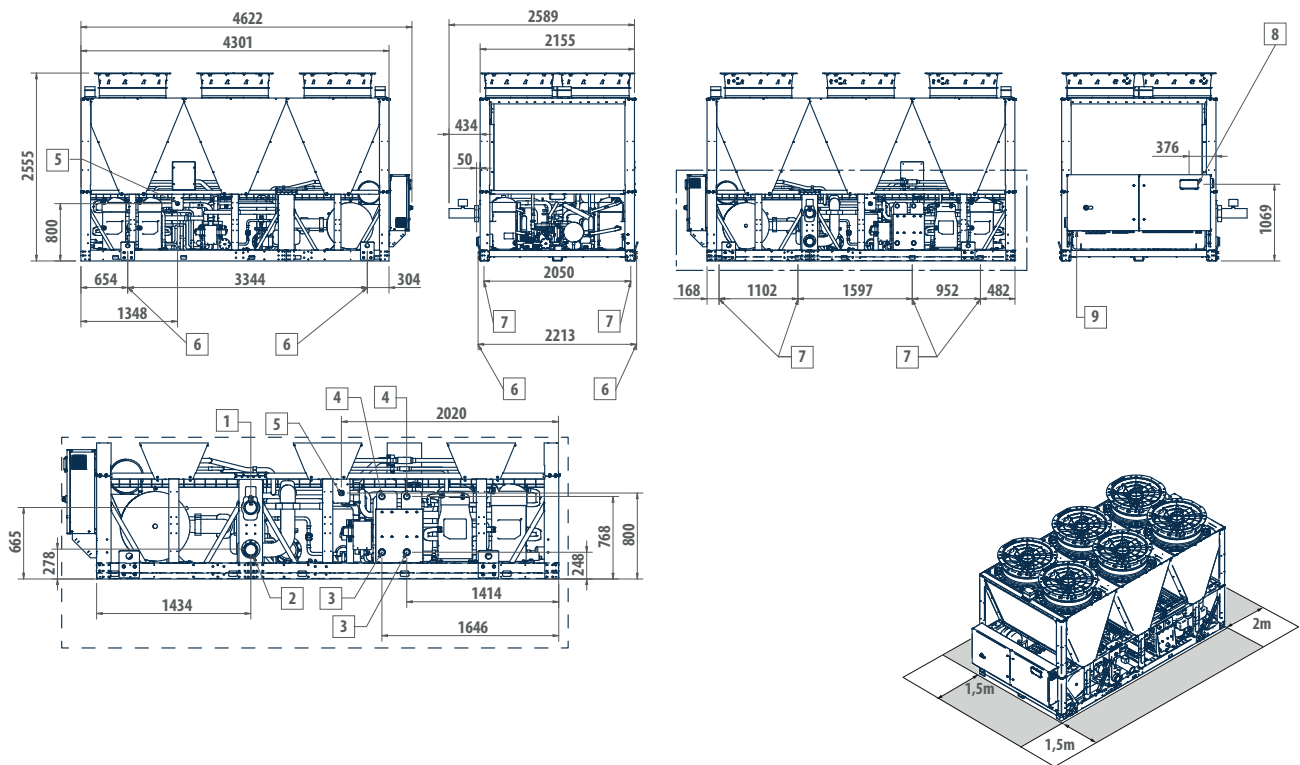

LEGEND

1	Water inlet Victaulic 4"
2	Water outlet Victaulic 4"
3	Heat exchanger inlet 2" M
4	Heat exchanger outlet 2" M
5	Outlet safety valve 1" M
6	Lifting points
7	Vibration dumpers
8	User interface
9	Power supply input

DIMENSIONAL DRAWINGS

VLS C 414 - 456

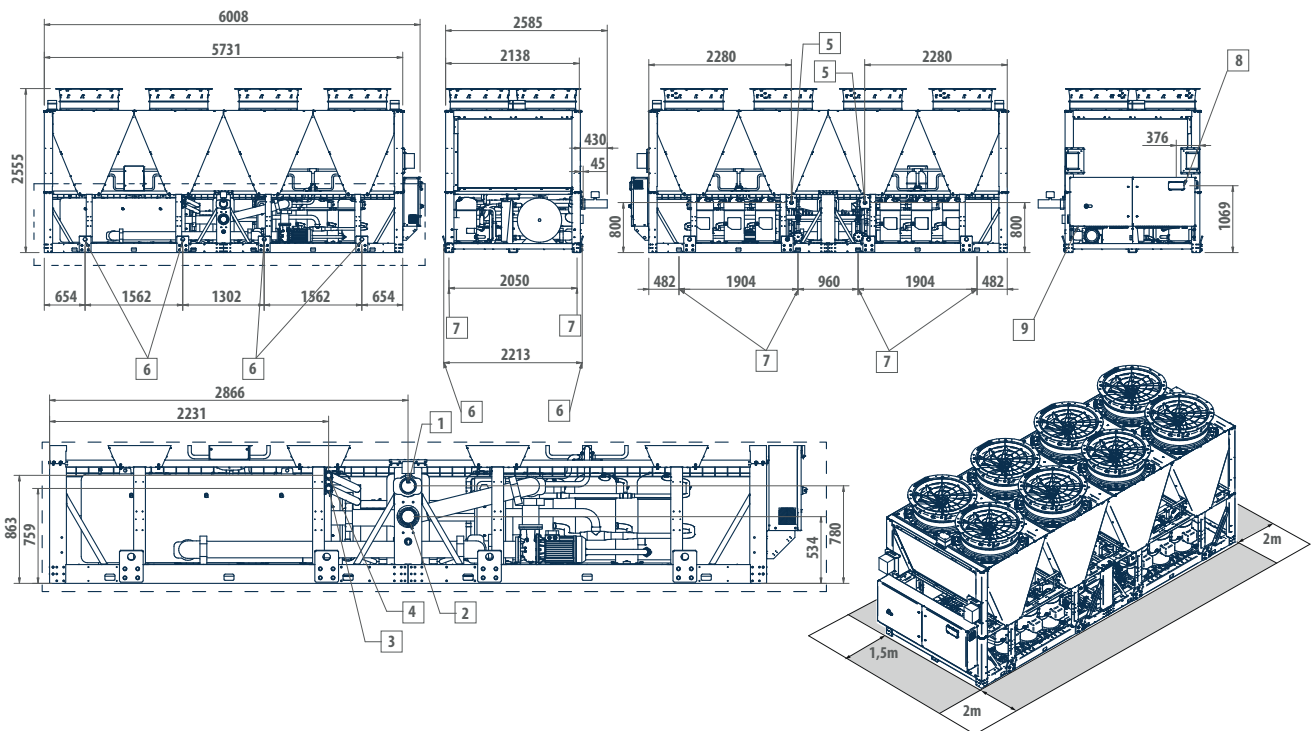

LEGEND

1	Water inlet Victaulic 4"
2	Water outlet Victaulic 4"
3	Heat exchanger inlet 2" M
4	Heat exchanger outlet 2" M
5	Outlet safety valve 1" M
6	Lifting points
7	Vibration dumpers
8	User interface
9	Power supply input

VLS Chillers and HP with Low GWP refrigerant

DIMENSIONAL DRAWINGS

VLS H 414 - 456

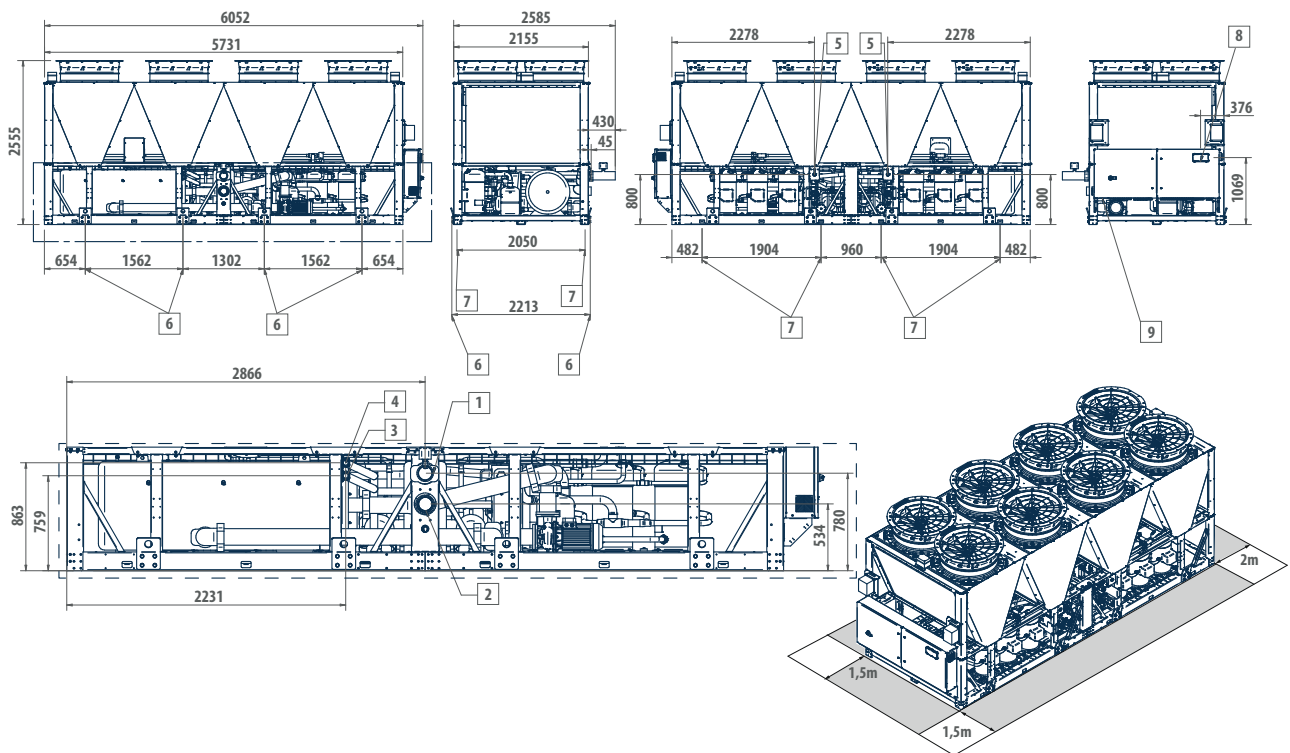

LEGEND

1	Water inlet Victaulic 4"
2	Water outlet Victaulic 4"
3	Heat exchanger inlet 2" M
4	Heat exchanger outlet 2" M
5	Outlet safety valve 1" M
6	Lifting points
7	Vibration dumpers
8	User interface
9	Power supply input

DIMENSIONAL DRAWINGS

VLS C 546 - 576

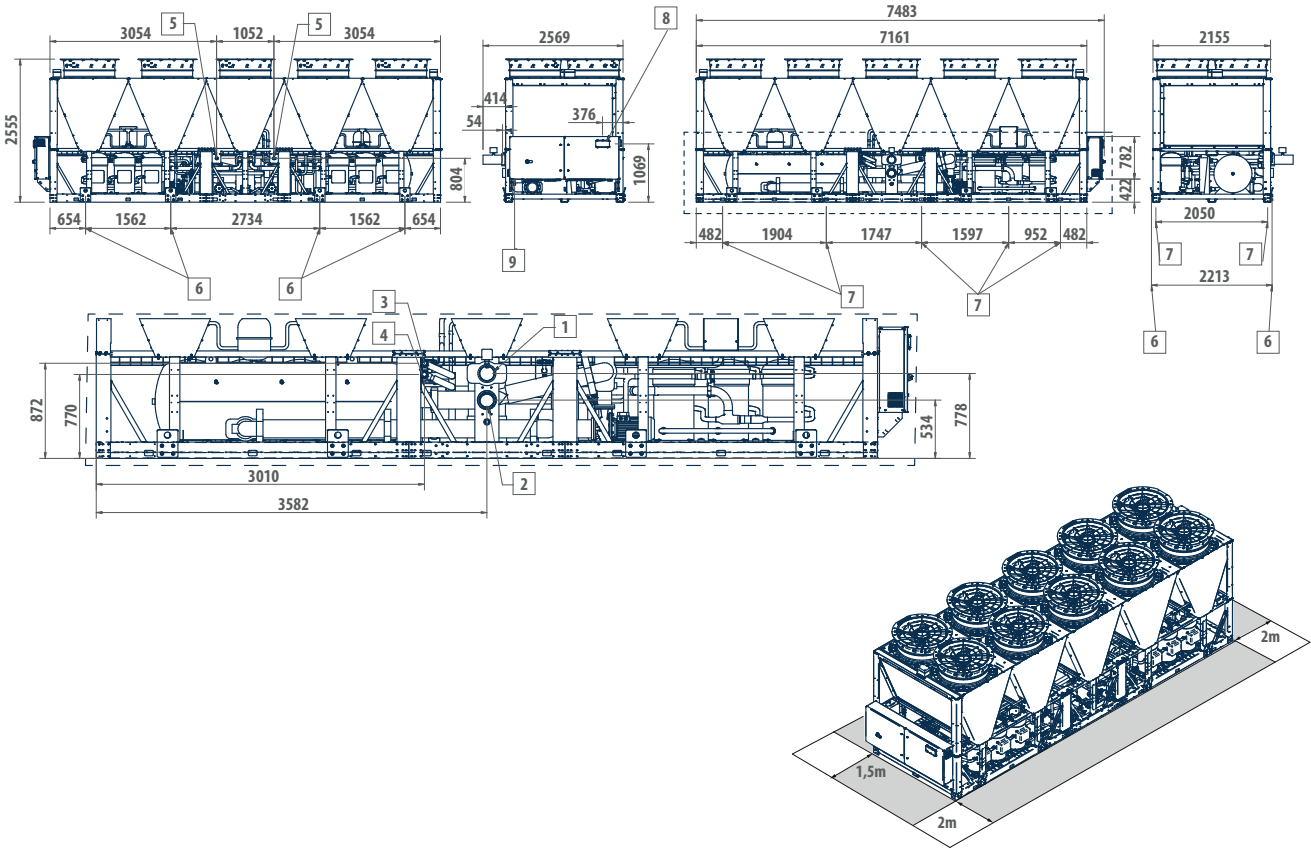

LEGEND

1	Water inlet Victaulic 5"
2	Water outlet Victaulic 5"
3	Heat exchanger inlet 2" M
4	Heat exchanger outlet 2" M
5	Outlet safety valve 1" M
6	Lifting points
7	Vibration dumpers
8	User interface
9	Power supply input

VLS Chillers and HP with Low GWP refrigerant

DIMENSIONAL DRAWINGS

VLS H 546 - 576

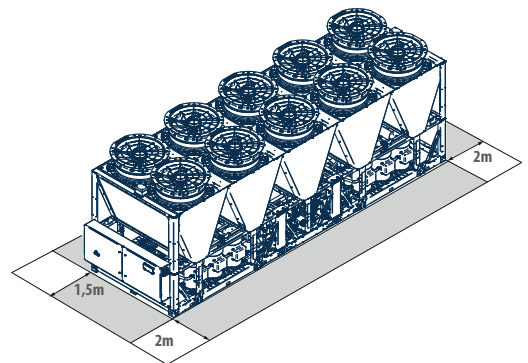
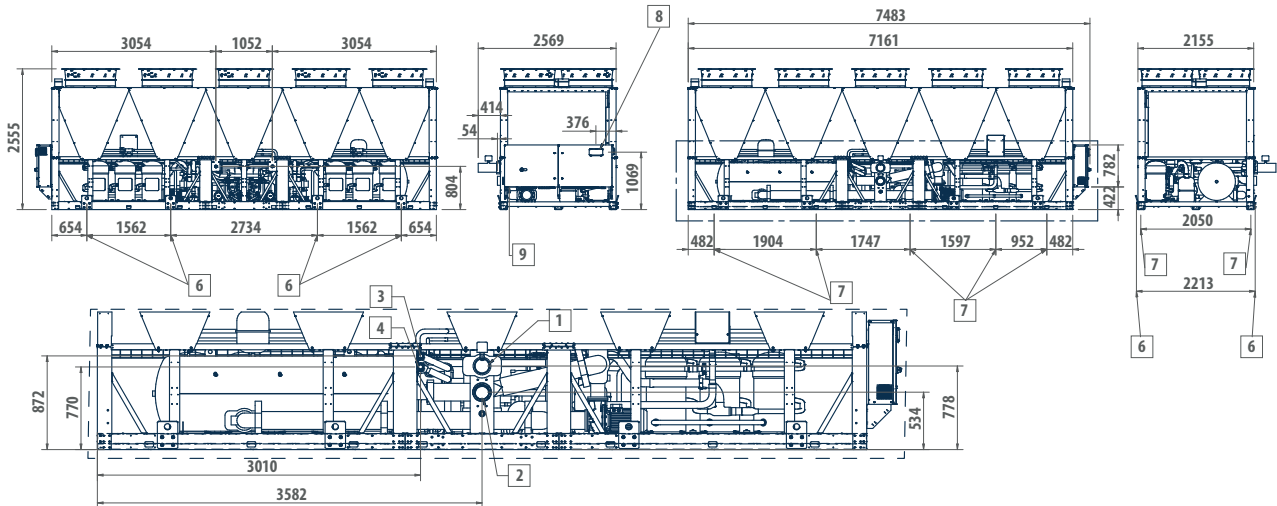

LEGEND

1	Water inlet Victaulic 5"
2	Water outlet Victaulic 5"
3	Heat exchanger inlet 2" M
4	Heat exchanger outlet 2" M
5	Outlet safety valve 1" M
6	Lifting points
7	Vibration dumpers
8	User interface
9	Power supply input

Outdoor packaged unit

GLE 650 - 1130 kW



A2L gas leak detection



R-454B refrigerant



Scroll compressor



Cooling only



Heating/
Cooling

PLUS

- » High efficiency when operating at partial load
- » Electronically controlled electric expansion valve
- » Incorporable hydronic kit
- » High configurability and wide availability of accessories
- » Compact dimensions
- » Use of low GWP refrigerant
- » 3 different acoustic configurations

The "W" configuration of the finned block heat exchangers makes it possible to have a large amount of exchange surface with a small footprint, thereby resulting in machines with high power density.

Multi-scroll solutions for reliability and high efficiency at partial loads with low GWP refrigerant

GLE is Galletti's range of air-cooled big capacity packaged chillers and heat pumps for outdoor installation featuring R454B refrigerant. R454B is a next generation A2L refrigerant with a GWP of only 467, one of the lowest on the market. This GWP value ensures that the GLE range complies with the gradual reduction of greenhouse gas emissions required by the F-GAS regulation, down to the stricter limits foreseen for 2030.

The range consists of 6 models with cooling capacities from 650 to 1130 kW, available in cooling only or reversible heat pump versions. The sizing and choice of individual components is intended to reduce energy consumption with a view to saving energy not only on each individual chiller but on the entire system. The high number of capacity control steps allows the unit to adapt its power to the actual needs of the system, with particular gains in efficiency under partial load conditions compared to traditional screw compressors.

The unit is suitable for being installed in environments where noise abatement is fundamentally important, thanks to the possibility of choosing from three sound-proofing set-ups.

The use of top quality components at the cutting edge of technology in the cooling, hydraulic, and electrical systems makes GLE chillers state of the art in terms of efficiency, reliability, and operating limits.

In fact, the ability to produce water from -10°C to 55°C, and full load operation with external air from -10°C to 45°C.

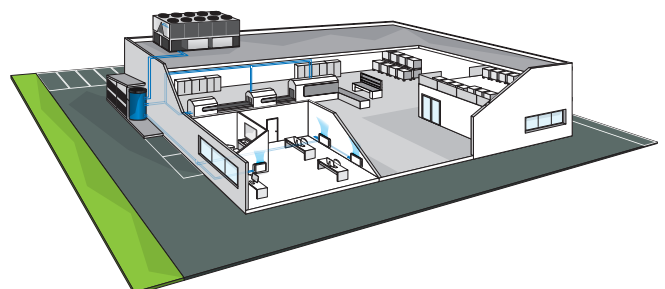

MAIN COMPONENTS

Structure

Painted galvanised sheet steel structure for an effective resistance to corrosive agents. Compressor compartment located below the finned heat exchangers to reduce the dimensions without compromising performance.

Compressors

Hermetic scroll compressors driven by electric motors and connected in tandem or trio version to maximize efficiency at partial loads.

Electronically controlled electric expansion valve

It represents, together with the compressor, the key component for the proper functioning of the unit. It optimizes the machines' operation at partial loads and increases the average seasonal energy efficiency.

Heat exchangers

Finned heat exchangers with copper pipes and aluminum fins in a "W"

Very low GWP refrigerant

Use of R454B refrigerant with low environmental impact. R454B is a next-generation A2L refrigerant with a GWP of only 467, one of the lowest on the market. This GWP value ensures the range complies with the gradual reduction of quotas of greenhouse refrigerants in the European market required by the F-GAS regulation, down to the stricter limits foreseen for 2030

Hydraulic kit

Option of choosing one or two pumps at standard or high head to meet system requirements, suitable for operation with glycol up to 30% and can be combined with a heat buffer tank.

CONFIGURATOR

The models are completely configurable by selecting the version and the options. To the right is shown an example of configuration.

Version	Field	1	2	3	4	5	6	7	8	9	10	11	12
GLE658CL		0	B	4	S	0	C	0	2	0	0	M	3

To verify the compatibility of the options, use the selection software or the price list.

AVAILABLE VERSIONS

Only cooling versions

GLE...CS	Standard execution
GLE...CL	Low noise execution
GLE...CQ	Super low noise execution

Heat pump versions

GLE...HS	Reversible, standard execution
GLE...HL	Reversible, low noise execution
GLE...HQ	Reversible, quite execution

CONFIGURATION OPTIONS

1 Power supply	8 Remote communication
0 400/3/50 + N	0 Absent
1 400V-3-50Hz + transformer	1 RS485 serial card (Modbus or Carel protocol)
2 400/3/50 + N + Circuit breakers	4 BACNET IP/pCOWeb serial board
3 400/3/50 + circuit breakers	5 BACNET IP / pCOWeb serial board + supervision software
2 Refrigerant	9 Special coils / Protective treatments
B R454B	0 Standard
3 User side water pump	B Epoxy pre-painted fin and overall painting
0 Absent	C Cataphoresis
1 Single pump	H Hydrophilic
2 Oversize single pump	R Copper / copper
5 Double pump in timed rotation	10 Packing
6 Oversize double pump in timed rotation	0 Standard
7 Single modulating pump (electr. Flow switch included)	1 Wooden cage
8 Single HP modulating pump (electr. Flow switch included)	2 Wooden crate
9 Double modulating pump (standby rotation) (electr. Flow switch included)	11 Anti vibration shock mounts
A Double HP modulating pump (standby rotation) (electr. Flow switch included)	0 Absent
4 Water buffer tank	G Rubber vibration dampers at the base of the unit
0 Absent	M Spring vibration dampers at the base of the unit
S Inertial tank on user side	12 Maintenance kit
5 Partial heat recovery (condensation control mandatory)	0 Absent
0 Absent	S Shut-off valves on compressor tandem / trio
D Desuperheater (recovery of 40% of Pf in rated conditions)	13 Documentation language
6 Air flow modulation	D German
C Condensation control by phase-cut fans	F French
E Condensation control with "EC brushless" electronic control fans	G English
7 Antifreezing kit	I Italian
0 Absent	N Dutch
E Protecting the water exchanger (standard machine)	P Polish
P Protecting the water exchanger and pump	R Russian
S Protecting the water exchanger, pump and tank	S Spanish

ACCESSORIES

A	Power factor capacitors	L	Filter shut-off kit (solenoid and tap on liquid line)
B	Soft starter	M	Special cable according to VDE regulation
C	Service kit (advanced controller required)	N	Remote control panel for programmable microprocessor
D	Pair of couplings Victaulic	P	Outdoor finned coil heat exchanger protection grille
E	ON/OFF status of the compressors	Q	Finned battery metal filters
F	Remote control for step capacity limit (advanced controller required)	R	Y-shaped water filter (loose delivered)
G	Configurable digital alarm board (advanced controller required)	S	Unit without refrigerant
H	Set point compensation outdoor temperature probe	T	Measurement and limitation of the absorbed current
I	Refrigerant pressure gauges		

Chillers and HP with Low GWP refrigerant GLE

GLE C WATER CHILLERS RATED TECHNICAL DATA

GLE		658	748	818	900	942	1072
Power supply		400 / 3+N / 50					
Cooling capacity	(1) kW	654	752	818	958	996	1132
Total power input	(1) kW	224	250	285	316	328	397
EER	(1)	2,92	3,00	2,87	3,03	3,04	2,85
SEER	(2)	4,88	4,97	4,94	5,09	5,32	5,27
Water flow	(1) l/h	112293	129189	140534	164558	171168	194427
Water pressure drop	(1) kPa	21	24	28	32	34	49
Available pressure head - LP pumps	(1) kPa	234	189	154	199	191	146
Available pressure head - HP pumps	(1) kPa	263	286	272	295	287	244
Maximum current absorption	A	527	666	647	749	787	907
Start up current	A	620	812	807	873	800	987
Compressors / circuits		8/4	8/4	8/4	10/4	12/4	12/4
Buffer tank volume	dm ³	1040	1040	1040	1040	1040	1040
Sound power level	(3) dB(A)	99	99	99	100	100	100
Sound power level, low-noise version	(3) dB(A)	97	97	97	98	98	98
Sound power level quiet version	(3) dB(A)	96	96	96	97	97	97
Weight without options	kg	4994	5564	5564	6428	6630	7440

(1) Outdoor air temperature 35°C, water temperature 12°C / 7°C (EN14511:2022)

(2) η efficiency values for heating and cooling are respectively calculated by the following formulas: [$\eta = SCOP / 2,5 - F(1) - F(2)$] e [$\eta = SEER / 2,5 - F(1) - F(2)$]. For further information, please refer to the technical document "ErP 2009/125/EC DIRECTIVE" in the catalogue introducing pages, or to the EN14825:2022 regulation.

(3) Sound power level measured according to ISO 9614

GLE H HEAT PUMPS RATED TECHNICAL DATA

GLE			658	748	818	900	942	1072
Power supply		V-ph-Hz	400 / 3+N / 50					
Cooling capacity	(1)	kW	654	749	812	937	977	1170
Total power input	(1)	kW	224	252	287	328	339	382
EER	(1)		2,92	2,96	2,83	2,86	2,88	3,06
SEER	(2)		4,88	4,91	4,87	4,78	5,03	5,40
Water flow	(1)	l/h	112293	128628	139550	161049	167925	200993
Water pressure drop	(1)	kPa	21	24	27	31	33	46
Available pressure head - LP pumps	(1)	kPa	234	190	157	204	196	139
Available pressure head - HP pumps	(1)	kPa	263	286	273	300	292	238
Heating capacity	(3)	kW	666	746	821	995	1030	1190
Total power input	(3)	kW	211	238	264	310	322	382
COP	(3)		3,15	3,13	3,11	3,21	3,20	3,12
Water flow	(3)	l/h	115645	129601	142675	172793	178947	206697
Water pressure drop	(3)	kPa	22	23	27	34	37	47
Available pressure head - LP pumps	(3)	kPa	223	187	147	184	174	124
Available pressure head - HP pumps	(3)	kPa	257	284	268	280	270	222
Maximum current absorption		A	527	591	647	757	795	922
Start up current		A	620	759	807	881	808	1002
Buffer tank volume		dm ³	1040	1040	1040	1040	1040	1040
Compressors / circuits			8/4	8/4	8/4	10/4	12/4	12/4
Sound power level	(4)	dB(A)	99	99	99	100	100	101
Sound power level, low-noise version	(4)	dB(A)	97	97	97	98	98	99
Sound power level quiet version	(4)	dB(A)	96	96	96	97	97	98
Length		mm	5060	6635	6635	8635	8635	10635
Depth		mm	2256	2256	2256	2256	2256	2256
Height		mm	2650	2650	2650	2650	2650	2650
Weight without options		kg	5196	5506	5642	7200	7508	8840

(1) Outdoor air temperature 35°C, water temperature 12°C / 7°C (EN14511:2022)

(2) η efficiency values for heating and cooling are respectively calculated by the following formulas: $[\eta = SCOP / 2,5 - F(1) - F(2)]$ e $[\eta = SEER / 2,5 - F(1) - F(2)]$. For further information, please refer to the technical document "ErP 2009/125/EC DIRECTIVE" in the catalogue introducing pages, or to the EN14825:2022 regulation.

(3) Outdoor air temperature dry bulb 7°C / wet bulb 6°C, water temperature 40°C / 45°C (EN14511:2022)

(4) Sound power level measured according to ISO 9614

Note: For dimensional drawing of heat pump models, contact the manufacturer.

Chillers and HP with Low GWP refrigerant GLE

DIMENSIONAL DRAWINGS

GLE 658 C

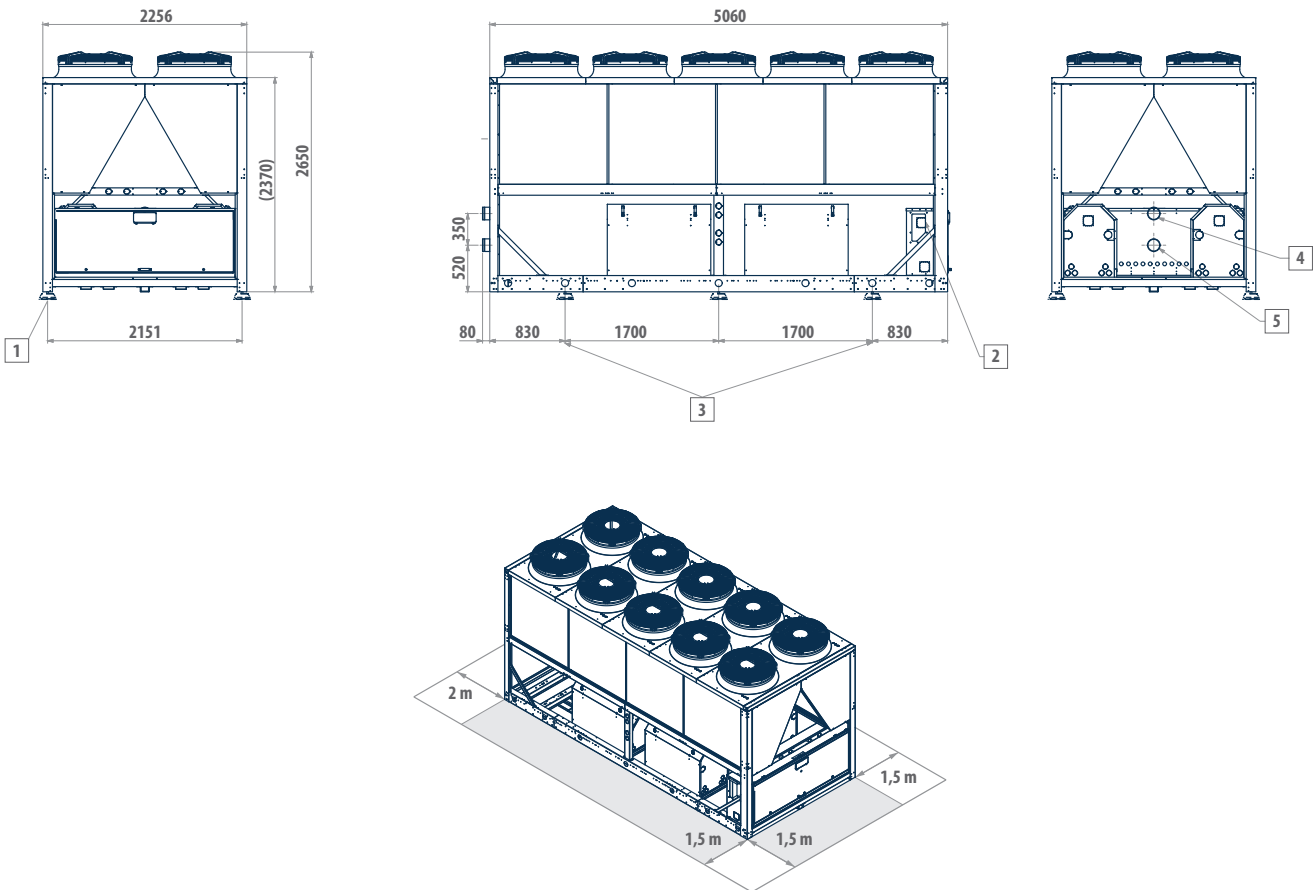

LEGEND

- | | |
|---|-----------------------------|
| 1 | Vibration dampers |
| 2 | Power supply input |
| 3 | Lifting points |
| 4 | Water inlet (5" Victaulic) |
| 5 | Water outlet (5" Victaulic) |

DIMENSIONAL DRAWINGS

GLE 748 - 818 C

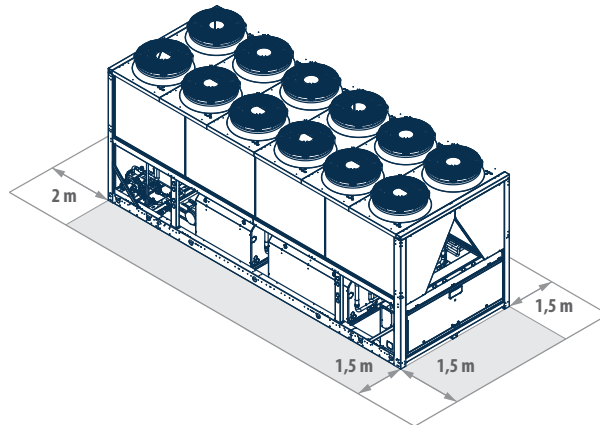
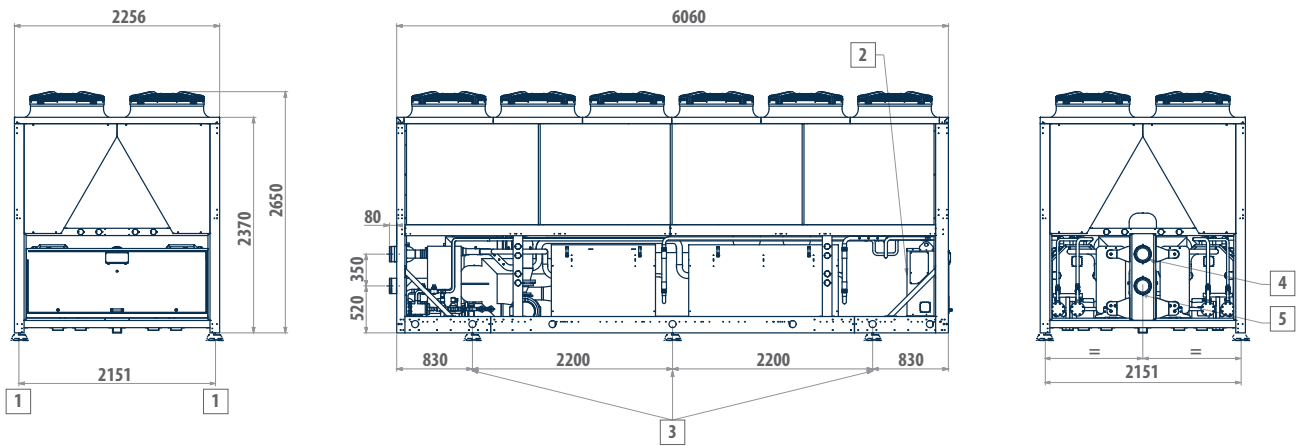

LEGEND

1	Vibration dampers
2	Power supply input
3	Lifting points
4	Water inlet (6" Victaulic)
5	Water outlet (6" Victaulic)

Chillers and HP with Low GWP refrigerant GLE

DIMENSIONAL DRAWINGS

GLE 900 - 942 C

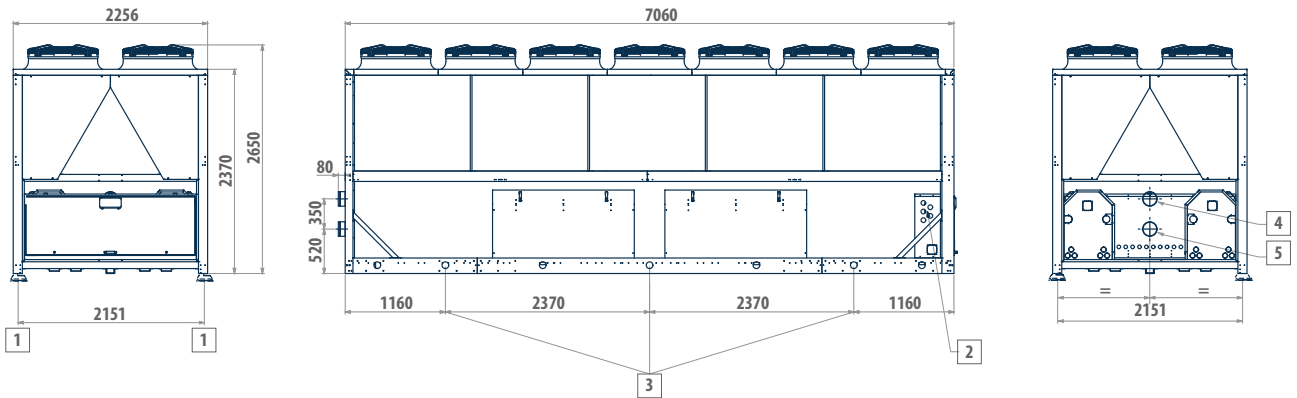

LEGEND

- | | |
|---|-----------------------------|
| 1 | Vibration dampers |
| 2 | Power supply input |
| 3 | Lifting points |
| 4 | Water inlet (6" Victaulic) |
| 5 | Water outlet (6" Victaulic) |

DIMENSIONAL DRAWINGS

GLE 1072 C

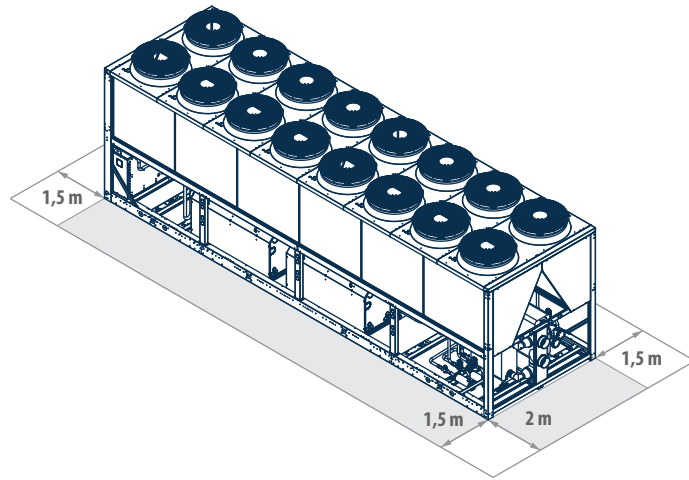
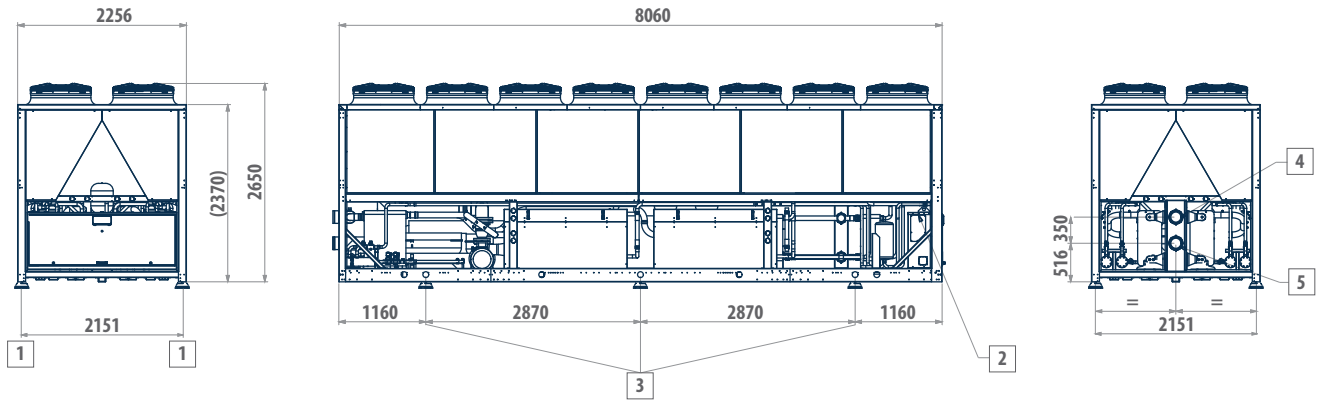

LEGEND

1	Vibration dampers
2	Power supply input
3	Lifting points
4	Water inlet (6" Victaulic)
5	Water outlet (6" Victaulic)
6	Optional heat recovery water outlet (Victaulic 4")
7	Optional heat recovery water inlet (Victaulic 4")

Outdoor motor-driven condensing units

MTE 5 - 166 kW

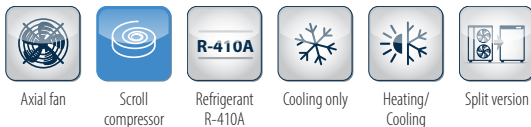

Efficiency and compactness for commercial air conditioning

MTE Air-cooled motocondensing packaged units are designed for outdoor installation in both residential and industrial applications.

The range uses R410A refrigerant, which assures high levels of performance with relatively low energy consumption and features 26 models in the chiller version, with cooling capacities ranging from 5 to 166 kW and 8 models in the heat pump version, with heating capacities ranging from 38 to 161 kW.

These units are employed in 2-section systems, which are normally connected to air evaporator coils in ducted air conditioning units.

Its extreme compactness facilitates the handling and installation of the units, even in situations with reduced installation space.

The equipment compartment is completely sealed and may be accessed on 3 sides thanks to easy-to-remove panels that greatly simplify maintenance and/or inspection. On request sound insulation makes it possible to further reduce the unit's noise emissions.

The cooling circuit is completely precharged with nitrogen. The liquid receiver (available as an optional accessory) compensates for variations in the load that occur in the system when the operating conditions change (day/night - summer/winter). Its use is also recommended for long sections of the circuit.

PLUS

- » Compact dimensions
- » Tandem solutions
- » Remote connectivity with the most common protocols
- » Available heating pump version on request

MTE condensing units are included in typical commercial applications where it is necessary to combine them with air evaporating units.

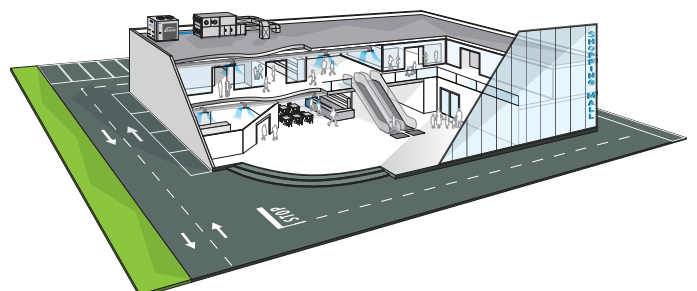

MAIN COMPONENTS

Structure

Painted galvanised sheet steel structure (RAL9002) for an effective resistance to corrosive agents. Fastening devices are made of non-oxidizable materials, or carbon steel that has undergone surface-passivating treatments.

Fan drive assembly

Axial fans with airfoil blades made of plastic-aluminum composite, connected to an electric motor with external rotor. The condensation control system continuously and automatically regulates the fan speed.

Compressor

Hermetic scroll type (rotary up to 7 kW), housed in a completely closed compartment that can be sound insulated. There is a heating element (standard feature) on the compressor's cover to counter oil dilution.

Electric control board

Electrical control panel with microprocessor controller accessible from the outside and low-voltage output for dry-contact thermostat control of the unit, external disconnect switch, phase sequence control.

Cooling circuit

- Dehydrating filter
- Flow indicator with humidity indicator
- High and low pressure switch
- Safety valve
- Shut-off valves on the liquid and gas line
- Nitrogen precharge under pressure
- Thermostatic valve, refrigerant pressure gauges, and liquid receiver as optional accessories

Heat exchanger

Made of 8 mm diameter copper pipes and aluminium fins, generously sized. A protection grille is available as an accessory.



CONFIGURATOR

The models are completely configurable by selecting the version and the options. To the right is shown an example of configuration.

Version	Field	1	2	3	4	5	6	7	8	9	10	11	12	13
MTE074COAA		0	2	S	0	C	1	1	M	0	0	G	1	1

To verify the compatibility of the options, use the selection software or the price list.

AVAILABLE VERSIONS

Only cooling versions

MTE..COAA

Power supply 400V-3N-50Hz

MTE..CMAA

Power supply 230V-1-50Hz

Heat pump versions

MTE..HOAA

Power supply 400V-3N-50Hz

CONFIGURATION OPTIONS

1 Expansion valve

- 0 Absent (not available for heat pump)
- A Electronic
- T Mechanical

2 Liquid receiver

- 0 Absent (not available for heat pump)
- 2 Present with valve

3 Refrigerant circuit accessories

- 0 Absent (not available for heat pump)
- S Solenoid valve

4 Partial heat recovery

- 0 Absent

5 Air flow modulation

- 0 Absent
- C Condensation control by phase-cut fans (heat pump mandatory)

6 Phase sequence switch

- 0 Absent (not available for heat pump)
- 1 Present (only 400 V - 3 N - 50 Hz)

7 Acoustic insulation and attenuation

- 0 Absent
- 1 Compressor compartment acoustic insulation
- 2 Compressor sound blanket
- 3 Compressor compartment acoustic insulation and sound blanket

8 Refrigerant pipework accessories

- 0 Absent
- M Refrigerant pressure gauges

9 Remote control / Serial communication

- 0 Absent
- 2 RS485 serial board (Carel / Modbus protocol)
- S Remote simplified user panel

10 Special coils / Protective treatments

- 0 Standard
- B Pre-painted fins with polyester paint
- C Cataphoresis treatment on fins and coil carpentry
- I Hydrophilic
- R Copper-copper

11 Outdoor finned coil heat exchanger protection

- 0 Absent
- G Selected

12 Compressors options

- 0 Absent (not available for heat pump)
- 1 Outdoor coil trace heater (heat pump)
- 2 Soft starter
- 3 Power factor capacitors
- 4 Power factor capacitors + soft starter
- 5 Outdoor coil trace heater (heat pump) + Rephasing capacitors

13 Onboard controller

- 1 Basic

ACCESSORIES

- A** Rubber anti vibration shock mounts
- B** Spring anti vibration shock mounts

- C** Mechanical and unidirectional remote valve KIT

Motor-driven condensing units MTE

RATED TECHNICAL DATA MOTOR-DRIVEN CONDENSING UNIT MTE C

MTE C			005M	007M	009	009M	010	010M	012	013
Power supply		V-ph-Hz	230 - 1 - 50	230 - 1 - 50	400 - 3N - 50	230 - 1 - 50	400 - 3N - 50	230 - 1 - 50	400 - 3N - 50	400 - 3N - 50
Cooling capacity	(1)	kW	5,40	7,16	9,04	8,84	9,66	9,66	12,5	13,7
Total power input	(1)	kW	1,71	2,24	2,90	3,59	3,27	3,27	4,24	4,31
EER	(1)		3,16	3,19	3,12	2,46	2,95	2,95	2,95	3,18
Maximum current absorption		A	12,0	16,0	7,00	20,0	9,00	23,0	11,0	11,0
Start up current		A	57	57	40	57	43	87	57	57
Compressors / circuits			1 / 1							
Sound power level	(2)	dB(A)	67	67	67	67	69	69	69	70
Transport / operating weight		kg	72	85	94	94	165	165	168	170

MTE C			015	018	021	024	029	033	038	042
Power supply		V-ph-Hz	400 - 3N - 50							
Cooling capacity	(1)	kW	15,6	18,5	21,0	24,7	28,7	32,4	37,9	42,6
Total power input	(1)	kW	5,36	6,59	7,40	8,28	10,1	11,7	12,2	13,3
EER	(1)		2,90	2,80	2,83	2,98	2,83	2,77	3,10	3,21
Maximum current absorption		A	12,0	17,0	18,0	20,0	28,0	31,0	34,0	36,0
Start up current		A	59	66	92	92	117	147	142	144
Compressors / circuits			1 / 1							
Sound power level	(2)	dB(A)	70	77	77	77	80	80	80	82
Transport / operating weight		kg	170	175	190	204	230	239	259	360

MTE C			053	059	066	074	082	096	108	129
Power supply		V-ph-Hz	400 - 3N - 50							
Cooling capacity	(1)	kW	53,6	59,1	67,0	74,6	82,3	98,4	110	130
Total power input	(1)	kW	15,9	17,9	20,9	23,3	27,0	32,2	38,3	39,5
EER	(1)		3,36	3,30	3,21	3,20	3,04	3,05	2,88	3,29
Maximum current absorption		A	46,0	49,0	56,0	61,0	69,0	81,0	90,0	103
Start up current		A	196	202	218	237	262	295	339	363
Compressors / circuits			2 / 1							
Sound power level	(2)	dB(A)	76	76	76	77	80	82	82	82
Transport / operating weight		kg	525	530	540	545	650	700	700	700

MTE C			142	163
Power supply		V-ph-Hz	400 - 3N - 50	
Cooling capacity	(1)	kW	140	166
Total power input	(1)	kW	44,0	57,1
EER	(1)		3,19	2,90
Maximum current absorption		A	112	136
Start up current		A	379	467
Compressors / circuits			2 / 1	2 / 1
Sound power level	(2)	dB(A)	82	83
Transport / operating weight		kg	910	970

- (1) Outdoor air temperature 35°C, evaporation temperature 5°
 (2) Sound power level measured according to ISO 9614

RATED TECHNICAL DATA MOTOR-DRIVEN CONDENSING UNIT MTE H

MTE H			038	053	074	096	108	129	142	163
Power supply		V-ph-Hz	400-3N-50							
Cooling capacity	(1)	kW	36,0	49,9	68,8	90,6	100	118	129	155
Total power input	(1)	kW	12,6	16,1	24,6	33,4	40,0	41,4	45,2	60,3
EER	(1)		2,86	3,09	2,80	2,71	2,50	2,86	2,85	2,58
Heating capacity	(2)	kW	37,4	50,3	70,8	93,3	106	120	132	161
Total power input	(2)	kW	11,9	15,7	21,9	29,4	33,5	37,3	40,4	51,0
COP	(2)		3,14	3,20	3,23	3,17	3,15	3,23	3,27	3,15
Maximum current absorption		A	34,0	45,0	59,0	79,0	88,0	100	107	133
Start up current		A	150	153	175	233	242	287	294	361
Compressors / circuits			1/1	2/1	2/1	2/1	2/1	2/1	2/1	2/1
Sound power level	(3)	dB(A)	77	77	78	81	81	82	82	85
Transport / operating weight		kg	319	536	549	714	714	906	939	988

(1) Outdoor air temperature 35°C, evaporation temperature 5°

(2) Outdoor air temperature 7°C dry bulb / 6°C wet bulb, condensation temperature 45°C

(3) Sound power level measured according to ISO 9614

Note: for other heat pump models contact the manufacturer.

Motor-driven condensing units MTE

DIMENSIONAL DRAWINGS

MTE 05 - 09

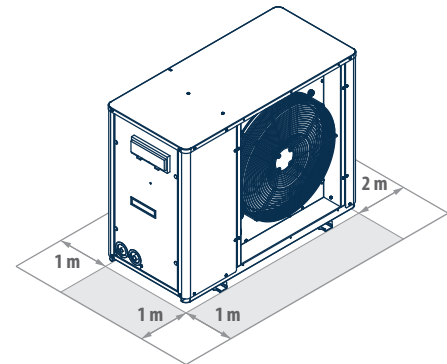
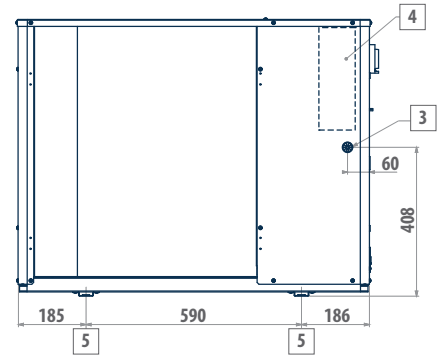
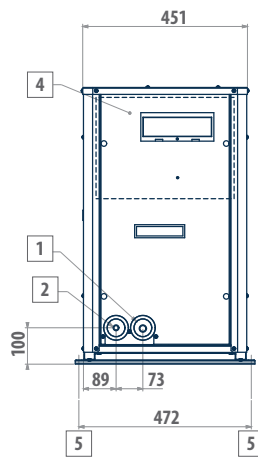
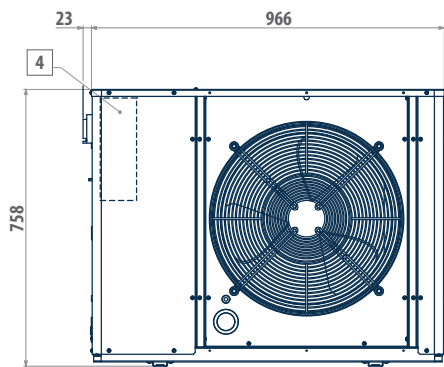

MTE 10 - 24

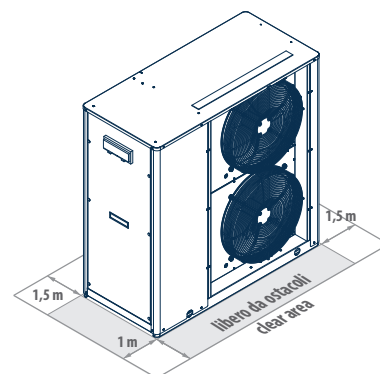
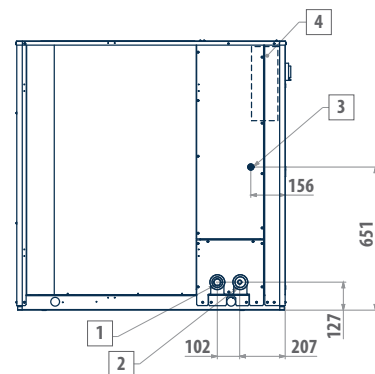
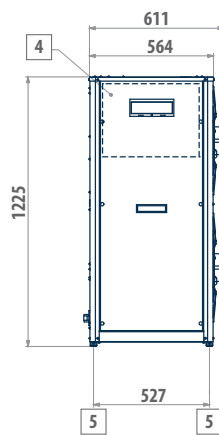
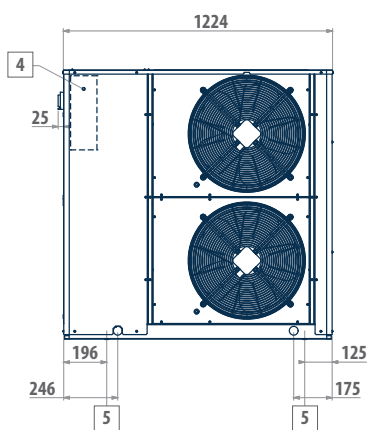

LEGEND

1	Gas inlet \varnothing 12 MTE 5; \varnothing 16 MTE 07-09
2	Liquid outlet \varnothing 12
3	Power supply \varnothing 37
4	Electric control board
5	Vibration dumpers

DIMENSIONAL DRAWINGS

MTE C 29 - 38 MTE H 38

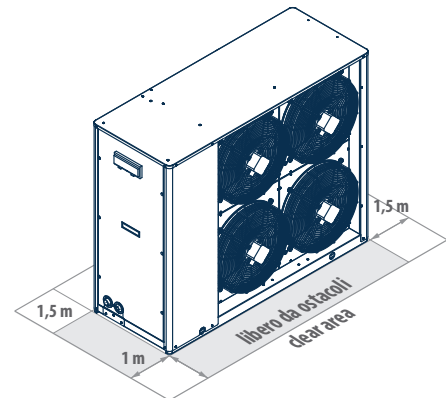
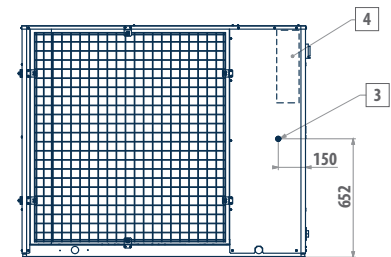
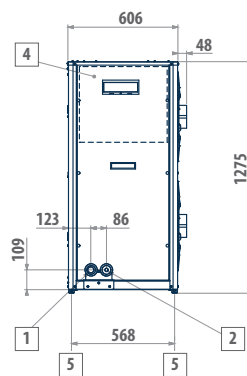
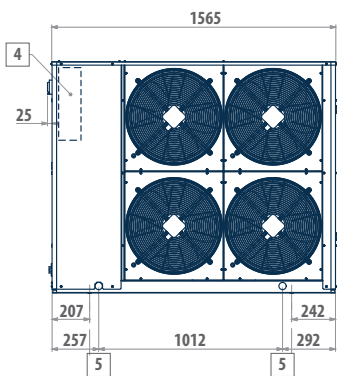

LEGEND

1	MTE C. gas inlet Ø 35; MTE H gas inlet Ø 22
2	Liquid outlet ø 16
3	Power supply ø 37
4	Electric control board
5	Vibration dumpers

Motor-driven condensing units MTE

DIMENSIONAL DRAWINGS

MTE 42

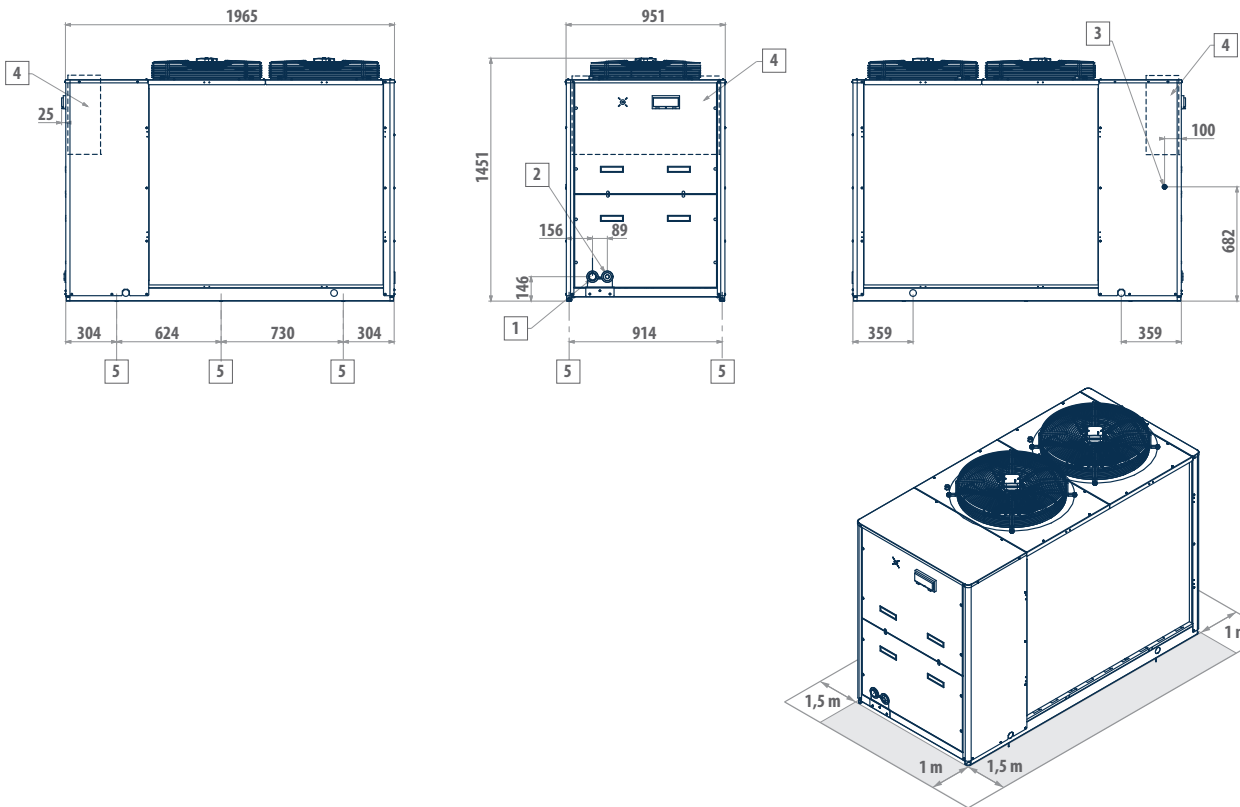

LEGEND

- | | |
|---|--------------------------------|
| 1 | Gas inlet \varnothing 42 |
| 2 | Liquid outlet \varnothing 22 |
| 3 | Power supply \varnothing 37 |
| 4 | Electric control board |
| 5 | Vibration dumpers |

DIMENSIONAL DRAWINGS

MTE C 53 - 82 MTE H 53-74

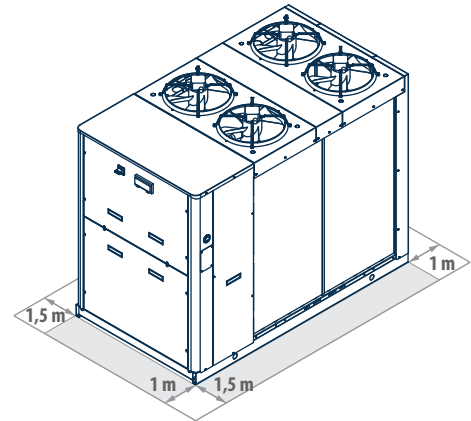
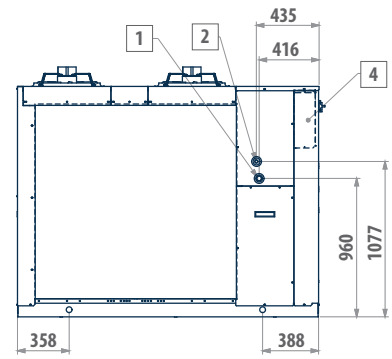
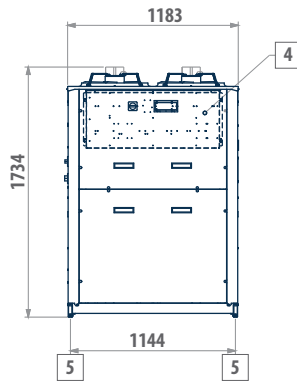
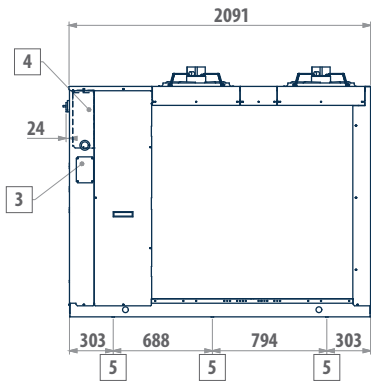

LEGEND

- | | |
|---|---|
| 1 | MTE C. gas inlet Ø 35; MTE H gas inlet Ø 22 |
| 2 | Liquid outlet ø 22 |
| 3 | Power supply |
| 4 | Electric control board |
| 5 | Vibration dumpers |

DIMENSIONAL DRAWINGS

MTE 96-108

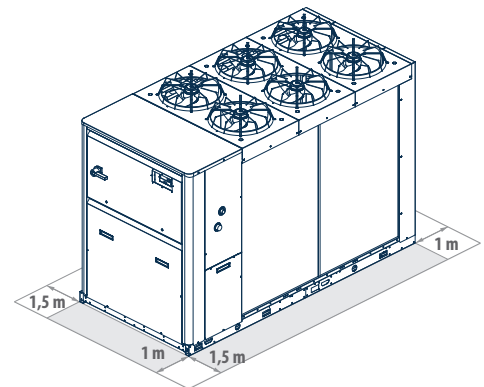
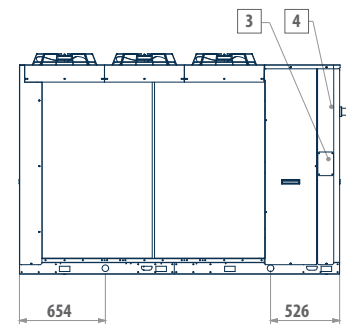
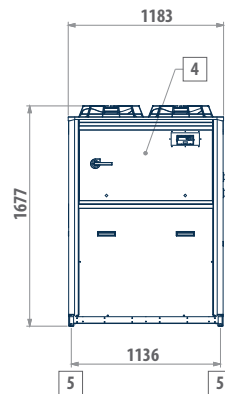
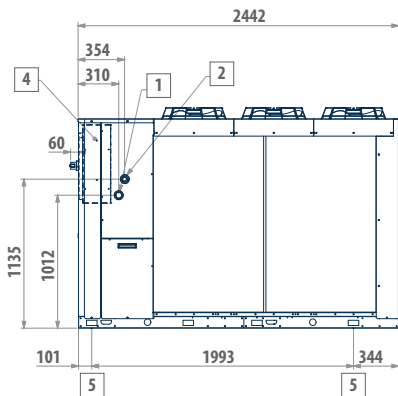

LEGEND

- | | |
|---|--|
| 1 | MTE C: inlet gas \varnothing 45; MTE H 96: inlet gas \varnothing 28; MTE H 108: inlet gas \varnothing 35 |
| 2 | MTE C: Liquid outlet \varnothing 28; MTE H: Liquid outlet \varnothing 22 |
| 3 | Power supply |
| 4 | Electric control board |
| 5 | Vibration dampers |

DIMENSIONAL DRAWINGS

MTE 129 - 163

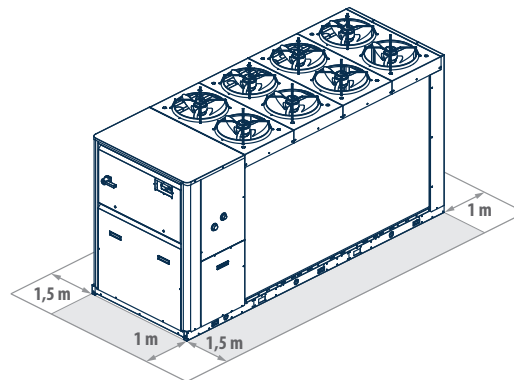
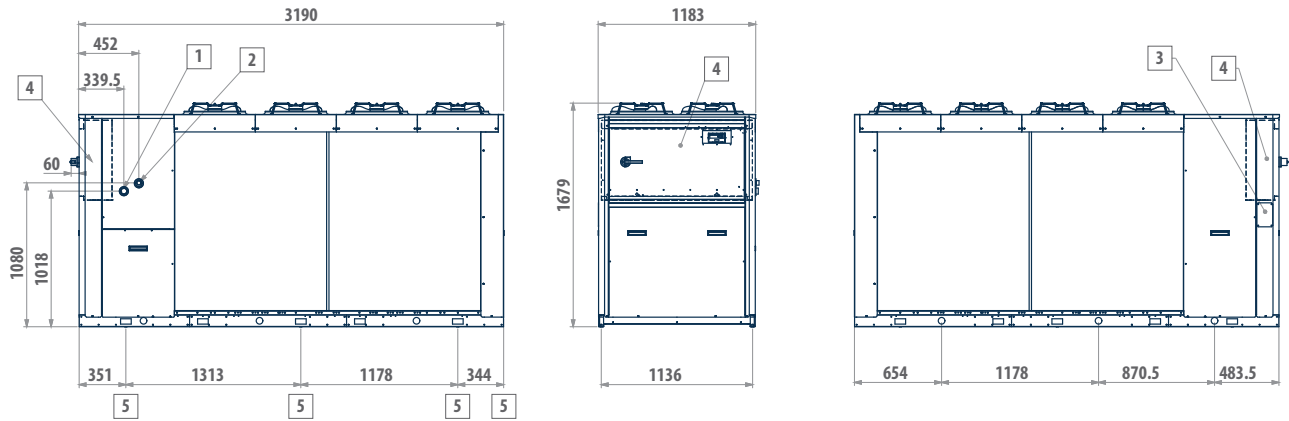

LEGEND

1	MTE C and MTE H 163: gas inlet Ø 42; MTE H 129 gas inlet Ø 35
2	Liquid outlet ø 28
3	Power supply
4	Electric control board
5	Vibration dumpers

Motor-driven evaporating units LRE

Indoor or outdoor motor-driven evaporating unit

LRE 40 kW - 680 kW



Scroll compressor



Refrigerant R-410A



Cooling only



Split version

PLUS

- » High seasonal efficiency values
- » Production of cold water down to -8°C
- » Electronic expansion valve
- » Up to 6 compressors
- » 1 or 2 cooling circuits
- » Remote connectivity with the most common protocols
- » Compact dimensions
- » 3 different acoustic configurations
- » Possibility of including an oil recovery kit for long-distance refrigeration lines within the unit

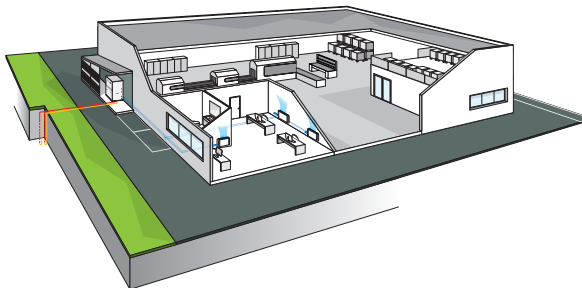

The possibility of keeping the evaporator indoors means there is no need to add glycol to the water inside the system. In addition, you can keep all components requiring maintenance in an easily accessible room.

High efficiency split unit with low acoustic impact

LRE is the new Galletti series of motor-driven evaporating unit for indoor or outdoors (with IP54 electrical panel option) installation, suitable for both air conditioning and industrial process applications. The range covers capacities from 40 kW up to a maximum of 750 kW and is characterised by reduced space requirements in order to facilitate access to technical compartments (for capacities of up to 560 kW, the width and height are less than 88 cm and 190 cm respectively).

In order to increase the efficiency at partial loads, LRE models are provided with tandem or trio solutions (2 or 3 compressors on a single circuit) and equipped with electronic expansion valve as standard. Both single and dual circuit versions are available.

The use of top quality components at the cutting edge of technology in the cooling and electrical systems makes LRE motor-driven evaporating units state of the art in terms of efficiency, reliability, and operating limits. In fact, the possibility of producing water down to -8 °C and condensing with maximum temperatures of 60 °C is guaranteed, in order to ensure minimum space requirements for the external fan unit even in the hottest climates.

The high configurability of the series, which is in the DNA of Galletti, is guaranteed by 2 different versions, with and without closing panels, and 3 different acoustic configurations: standard, low noise, and super low noise, able to ensure a sound power level reduction of up to 12 dB(A). The range of the configuration available is completed by the possibility of producing hot water up to 60 °C at zero cost through partial heat recovery.

It is also possible to provide an oil recovery kit inside the refrigerator compartment to prevent it from being trapped in the connection refrigerant lines between the indoor unit and the external condenser when the distances, due to the requirements of the installation site, are characterized by long lengths.

Finally, the advanced microprocessor that regulates the operation of the unit allows: the control of a maximum 2 user-side pumps, on/off or modulating, the possibility of cascade connection up to 6 units and the control of the modulation of the air flow in the remote condenser unit with single or double 0-10V signal.

MAIN COMPONENTS

Structure

Made in galvanised steel sheet with a polyester powder coating for outdoors.

On request the compressor compartment is completely sealed and accessible on 3 sides thanks to easily removable panels that greatly simplify all maintenance and inspection operations.

Compressori scroll

Scroll-type compressors in a tandem or trio configuration equipped with IDV valve. The IDV intermediate delivery valve technology allows the compressor to avoid losses caused by overcompression and, consequently, the additional work the motor has to perform in partial-load operation, saving energy and improving seasonal and partial-load efficiency from 3% to 10%.



Heat exchangers

All units have heat exchangers with braze-welded AISI 316 austenitic stainless steel plates and connections made of AISI 316 L, characterised by a reduced carbon content to facilitate brazing.

Electronic microprocessor control

It allows complete management of the unit. The electronic control system allows the setpoint to be adjusted automatically according to the outdoor temperature in order to reduce consumption and broaden the working temperature range. With the advanced microprocessor control it is possible to set up LAN networks for controlling 6 units in parallel.

Oil recovery kit

Necessary in case of long distances between indoor unit and remote condenser. The separator, by intercepting the oil carried by the compressed gas, and returning it regularly to the carter of the machine, helps to ensure the effective lubrication of the moving parts of the compressor.

CONFIGURATOR

The models are completely configurable by selecting the version and the options. To the right is shown an example of configuration.

Version	Field	1	2	3	4	5	6	7	8	9	10	11
LRE132CSG		2	B	0	P	0	1	G	0	0	0	0

To verify the compatibility of the options, use the selection software or the price list.

AVAILABLE VERSIONS

Only cooling versions

LRE...CSG
LRE...CLG
LRE...CQG

Standard execution
Low noise execution
Super low noise execution

CONFIGURATION OPTIONS

1 Power supply

- 0 400/3/50 + N
- 1 400/3/50
- 2 400/3/50 + N + Circuit breakers
- 3 400/3/50 + circuit breakers

2 Control microprocessor and lamination device

- B Advanced + electronic expansion valve

3 Partial heat recovery

- 0 Absent
- D Desuperheater (partial heat recovery)

4 Outdoor unit air flow modulation

- 0 Absent
- I Condensation control performed by one 0-10V signal for each refrigerant circuit
- P Condensation control performed by a single 0-10V signal

5 User water flow modulation

- 1 Single pump
- 2 Dual pump
- 3 Single pump + output signal with water flow modulation in ΔT logic = cost
- 4 Dual pump + output signal with water flow modulation in ΔT logic = cost
- 5 Single pump + output signal with water flow modulation in T logic = cost
- 6 Dual pump + output signal with water flow modulation in T logic = cost

6 Remote communication

- 0 Absent
- 1 RS485 serial card (Modbus or Carel protocol)
- 3 Ethernet card (SNMP or BACNET protocol) + clock card
- 4 Ethernet card + clock card + monitoring software

7 Anti vibration shock mounts

- 0 Absent
- G Rubber vibration dampers at the base of the unit
- M Spring vibration dampers at the base of the unit

8 Packing

- 0 Standard
- 1 Wooden cage
- 2 Wooden crate

9 Remote control

- 0 Absent
- 1 Simplified remote control panel
- 3 Remote display for programmable microprocessor

10 Anti-intrusion panelling

- 0 Absent
- P Present (standard for Q version and mandatory for field 11 = 1)

11 Unit installation

- 0 Indoor installation
- 1 Outdoor installation

ACCESSORIES

A	Power factor capacitors	I	Pair of couplings Victaulic
B	Soft starter	L	Filter regulating kit
C	Service kit (advanced controller required)	M	Set point compensation outdoor temperature probe
D	Oil recovery kit for refrigerant pipes > 30 m	N	Compressor tandem/trio isolation valves
E	ON/OFF status of the compressors	P	Unit lifting pipes
F	Remote control for step capacity limit (advanced controller required)	Q	Temperature probe for pump shutdown on the primary circuit
G	Configurable digital alarm board (advanced controller required)	T	Mains power analyzer for monitoring and reducing power consumption
H	Refrigerant pressure gauges	V	Set-point modification with 4-20mA signal

Motor-driven evaporating units LRE

RATED TECHNICAL DATA OF LRE C MOTOR-DRIVEN EVAPORATING UNITS

LRE			052	062	072	082	092	122	132	
Power supply		V-ph-Hz	400/3N/50							
Cooling capacity	(1)	kW	40,9	51,3	59,6	69,8	80,3	103	118	
Total power input	(1)	kW	13,4	16,6	19,5	22,7	26,2	33,7	38,3	
EER	(1)		3,06	3,09	3,06	3,08	3,06	3,07	3,07	
Water flow	(1)	l/h	7038	8837	10260	12021	13821	17792	20256	
Water pressure drop	(1)	kPa	39	39	37	38	38	37	37	
Maximum current absorption		A	29,0	36,0	42,0	49,0	57,0	72,0	81,0	
Start up current		A	112	161	211	218	178	288	296	
Startup current with soft starter		A	67	97	127	131	107	173	178	
Compressors / circuits			2/1							
Sound power level	(2)	dB(A)	73	75	76	77	80	80	82	
Sound power level, low-noise version	(2)	dB(A)	67	69	70	71	74	74	76	
Sound power level quiet version	(2)	dB(A)	61	63	64	65	68	68	70	
Weight without options		kg	293	311	321	339	383	529	581	

LRE			152	154	182	184	212	214	242	
Power supply		V-ph-Hz	400/3N/50							
Cooling capacity	(1)	kW	136	131	161	163	190	188	214	
Total power input	(1)	kW	43,8	42,1	48,7	51,3	57,3	58,8	62,5	
EER	(1)		3,10	3,10	3,30	3,17	3,32	3,19	3,42	
Water flow	(1)	l/h	23359	22470	27638	27976	32733	32292	36807	
Water pressure drop	(1)	kPa	37	28	32	30	33	33	30	
Maximum current absorption		A	91,0	90,0	112	114	130	128	151	
Start up current		A	356	224	380	293	399	307	420	
Startup current with soft starter		A	214	153	228	199	239	210	252	
Compressors / circuits			2/1	4/2	2/1	4/2	2/1	4/2	2/1	
Sound power level	(2)	dB(A)	87	79	87	83	89	83	89	
Sound power level, low-noise version	(2)	dB(A)	81	73	83	77	84	77	85	
Sound power level quiet version	(2)	dB(A)	75	67	77	71	78	71	79	
Weight without options		kg	650	949	674	884	746	920	816	

(1) Water temperature - user side 12°C / 7°C, condensation temperature 50°C (EN14511:2022)

(2) Sound power level measured according to ISO 9614

RATED TECHNICAL DATA OF LRE C MOTOR-DRIVEN EVAPORATING UNITS

LRE			244	274	302	314	364	384	454
Power supply		V-ph-Hz	400/3N/50						
Cooling capacity	(1)	kW	209	238	266	275	319	340	395
Total power input	(1)	kW	65,9	74,9	78,7	85,2	98,3	106	117
EER	(1)		3,17	3,17	3,39	3,23	3,24	3,22	3,37
Water flow	(1)	l/h	35979	40901	45787	47326	54801	58363	67822
Water pressure drop	(1)	kPa	35	36	36	36	37	37	23
Maximum current absorption		A	144	161	166	182	224	240	261
Start up current		A	360	377	510	447	492	508	529
Startup current with soft starter		A	244	259	306	305	340	353	369
Compressors / circuits			4/2	4/2	2/1	4/2	4/2	4/2	4/2
Sound power level	(2)	dB(A)	83	85	91	90	90	90	92
Sound power level, low-noise version	(2)	dB(A)	77	79	88	84	86	86	87
Sound power level quiet version	(2)	dB(A)	71	73	82	78	80	80	81
Weight without options		kg	932	1034	1048	1314	1398	1422	1719

LRE			504	564	606	636	696	746
Power supply		V-ph-Hz	400/3N/50					
Cooling capacity	(1)	kW	443	490	513	557	615	658
Total power input	(1)	kW	129	145	156	170	176	188
EER	(1)		3,44	3,39	3,28	3,28	3,49	3,51
Water flow	(1)	l/h	76106	84244	88214	95637	105646	113024
Water pressure drop	(1)	kPa	27	33	33	36	37	37
Maximum current absorption		A	303	317	328	370	412	454
Start up current		A	571	661	593	638	680	722
Startup current with soft starter		A	403	460	421	457	491	524
Compressors / circuits			4/2	4/2	6/2	6/2	6/2	6/2
Sound power level	(2)	dB(A)	92	93	94	94	94	94
Sound power level, low-noise version	(2)	dB(A)	88	90	88	89	89	90
Sound power level quiet version	(2)	dB(A)	82	84	82	83	83	84
Weight without options		kg	1762	1829	2349	2446	2378	2460

(1) Water temperature - user side 12°C / 7°C, condensation temperature 50°C (EN14511:2022)

(2) Sound power level measured according to ISO 9614

Motor-driven evaporating units LRE

DIMENSIONAL DRAWINGS

LRE 52 - 92

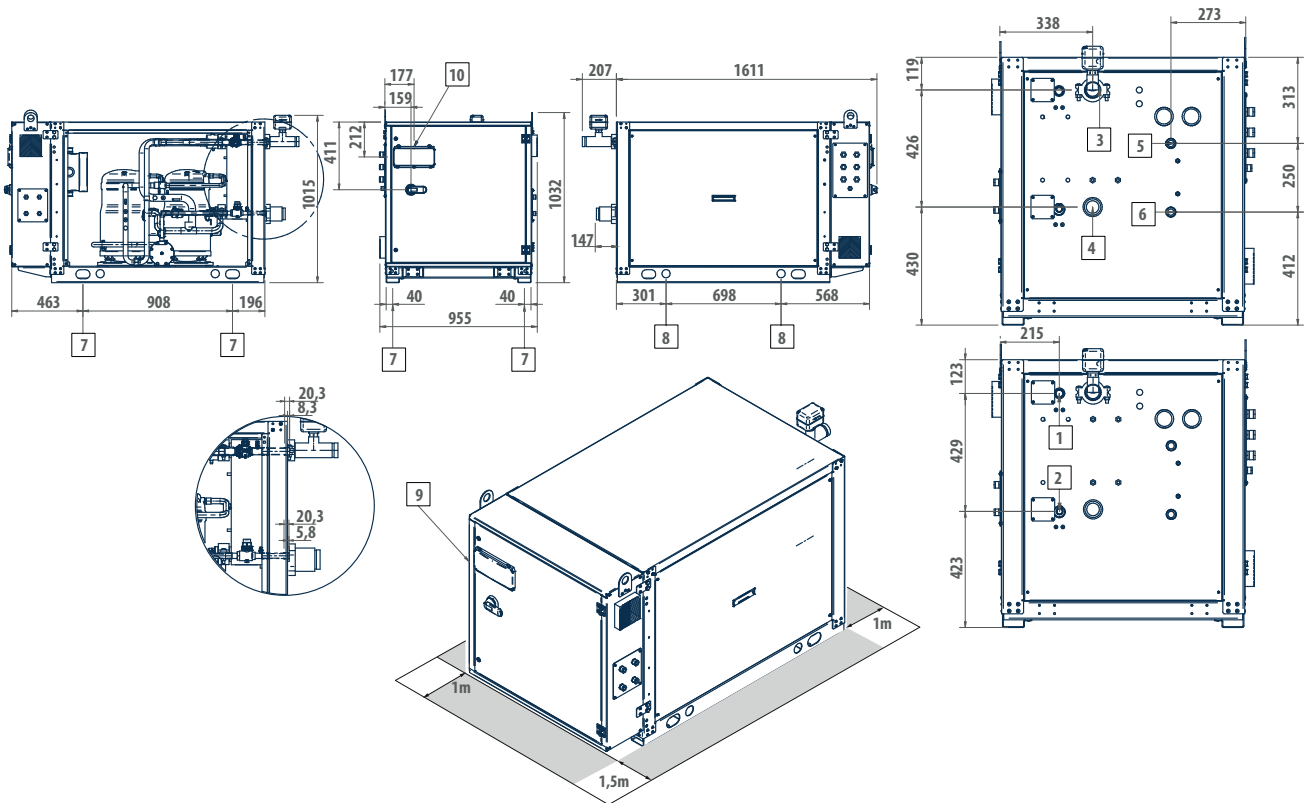

LEGEND

1	Refrigerant outlet
2	Refrigerant return
3	User side - inlet (Victaulic 2")
4	User side - outlet (Victaulic 2")
5	De-superheater water outlet 1"
6	Desuperheater water inlet 1"
7	Vibration dumpers
8	Lifting points
9	Power supply input
10	User interface

CLOSING PANNELLING AVAILABLE ON REQUEST

LRE	052	062	072	082	092
1) Ø	18	22	22	22	28
2) Ø	18	18	22	22	22

DIMENSIONAL DRAWINGS

LRE 122 - 152

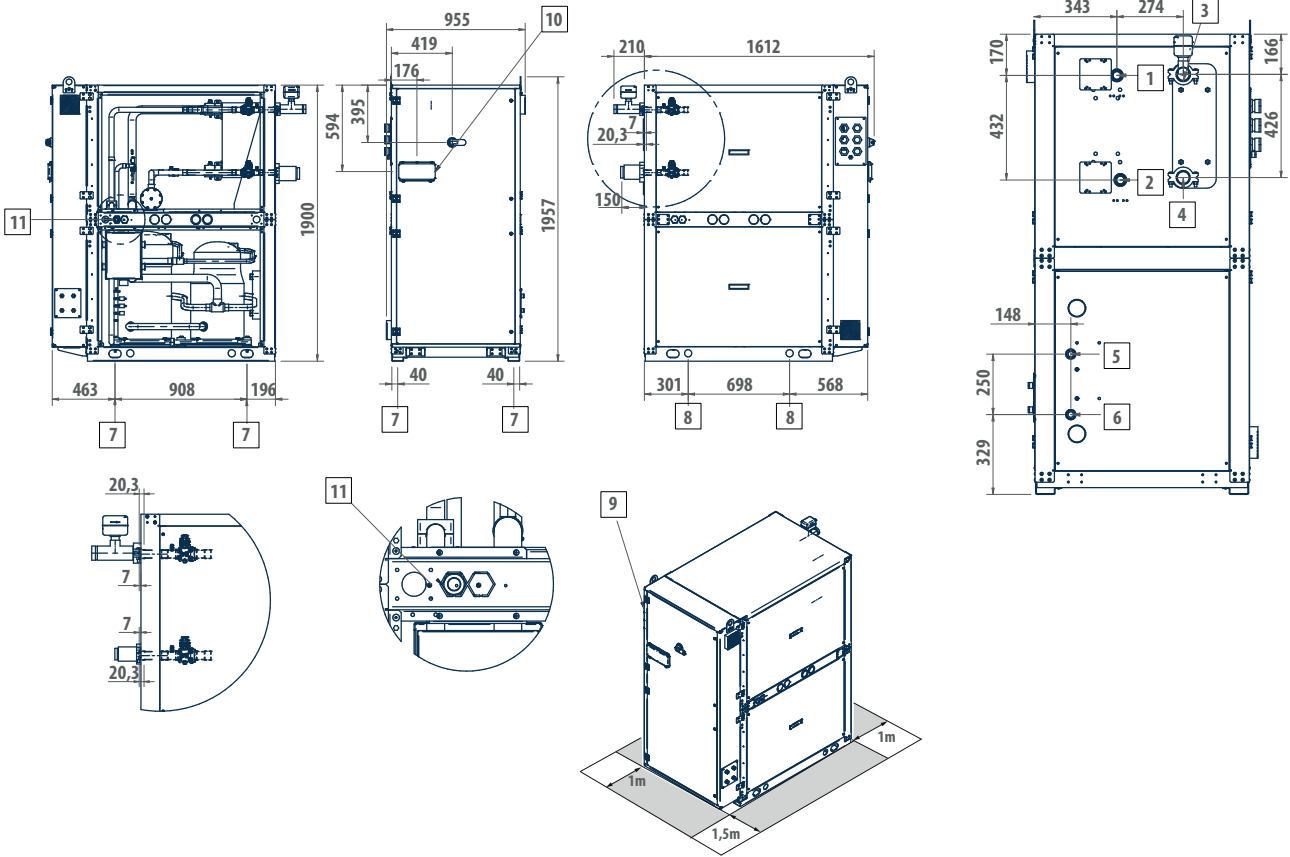

LEGEND

1	Refrigerant outlet
2	Refrigerant return
3	User side - inlet (Victaulic 2")
4	User side - outlet (Victaulic 2")
5	De-superheater water outlet 1"
6	Desuperheater water inlet 1"
7	Vibration dumpers
8	Lifting points
9	Power supply input
10	User interface
11	Outlet safety valve G. 3/4" F (only 152)

CLOSING PANELLING AVAILABLE ON REQUEST

LRE	122	132	152
1) Ø	28	42	42
2) Ø	28	28	35

Motor-driven evaporating units LRE

DIMENSIONAL DRAWINGS

LRE 182 - 242

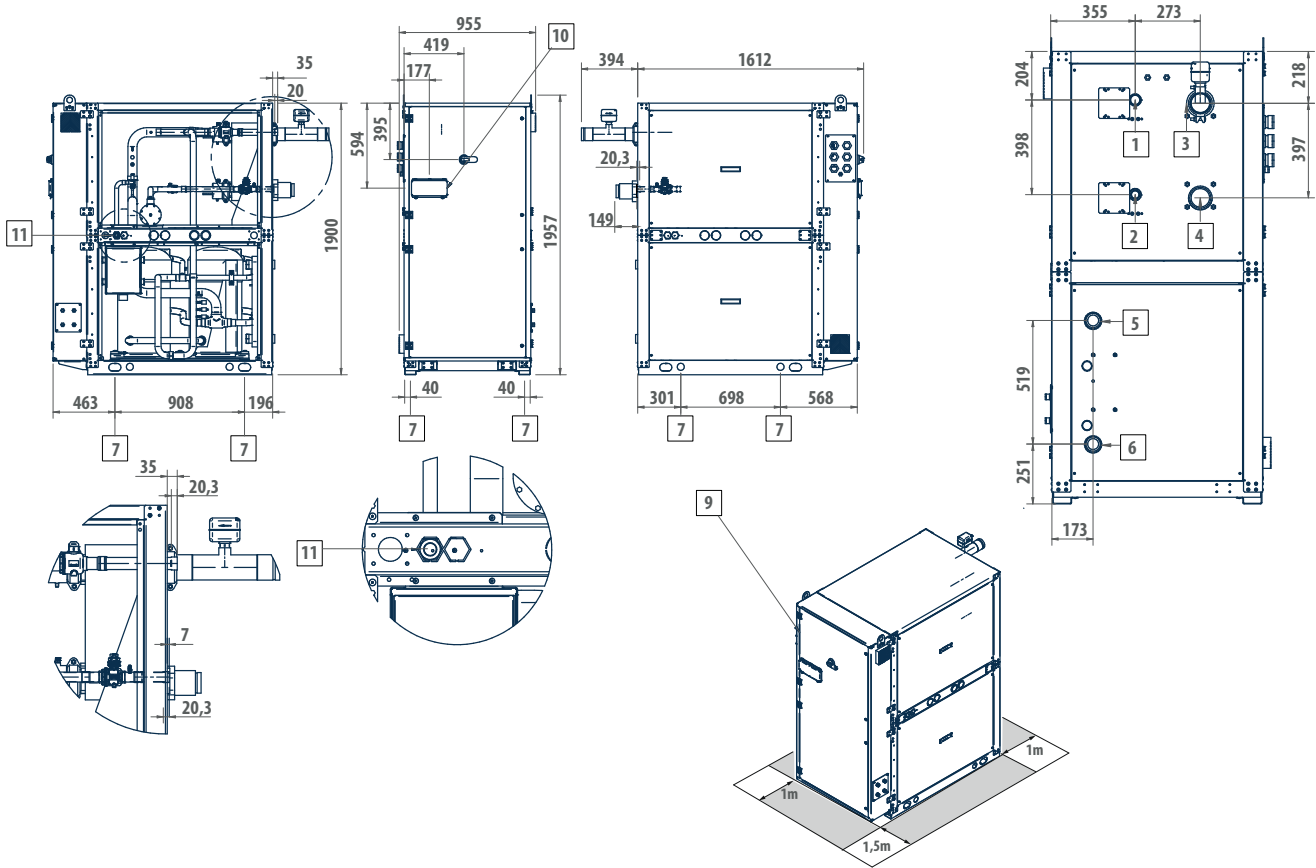

LEGEND

1	Refrigerant outlet
2	Refrigerant return
3	User side - inlet (Victaulic 3")
4	User side - outlet (Victaulic 3")
5	De-superheater water outlet 2"
6	Desuperheater water inlet 2"
7	Vibration dumpers
8	Lifting points
9	Power supply input
10	User interface
11	Outlet safety valve G. 3/4" F

CLOSING PANELLING AVAILABLE ON REQUEST

LRE	182	212	242
1) Ø	42	42	42
2) Ø	35	35	35

DIMENSIONAL DRAWINGS

LRE 154-274

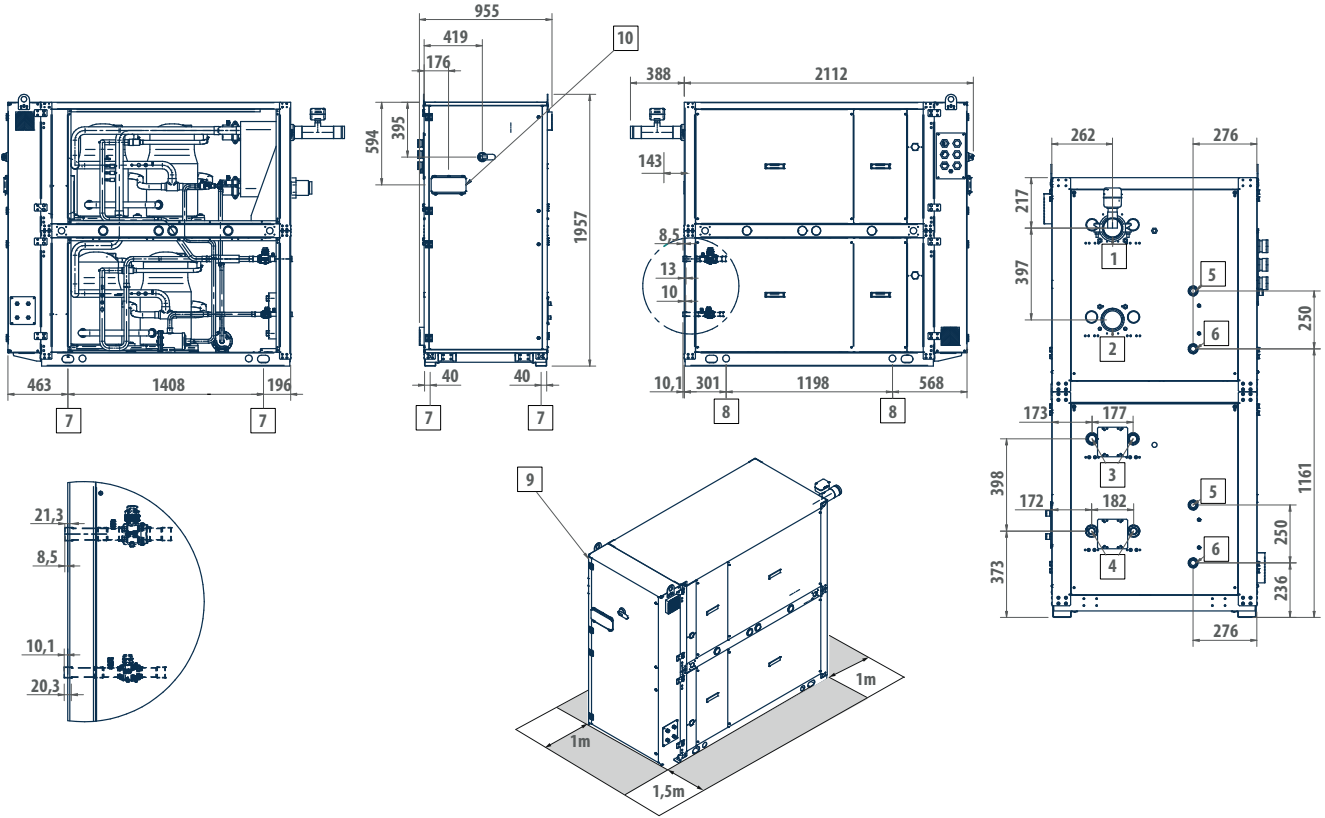

LEGEND

1	User side - inlet (Victaulic 3")
2	User side - outlet (Victaulic 3")
3	Refrigerant outlet
4	Refrigerant return
5	De-superheater water outlet 2"
6	Desuperheater water inlet 2"
7	Vibration dumpers
8	Lifting points
9	Power supply input
10	User interface

CLOSING PANNELLING AVAILABLE ON REQUEST

LRE	154	184	214	244	274
3) Ø	28	28	28	28	35
4) Ø	22	22	28	28	28

Motor-driven evaporating units LRE

DIMENSIONAL DRAWINGS

LRE 302

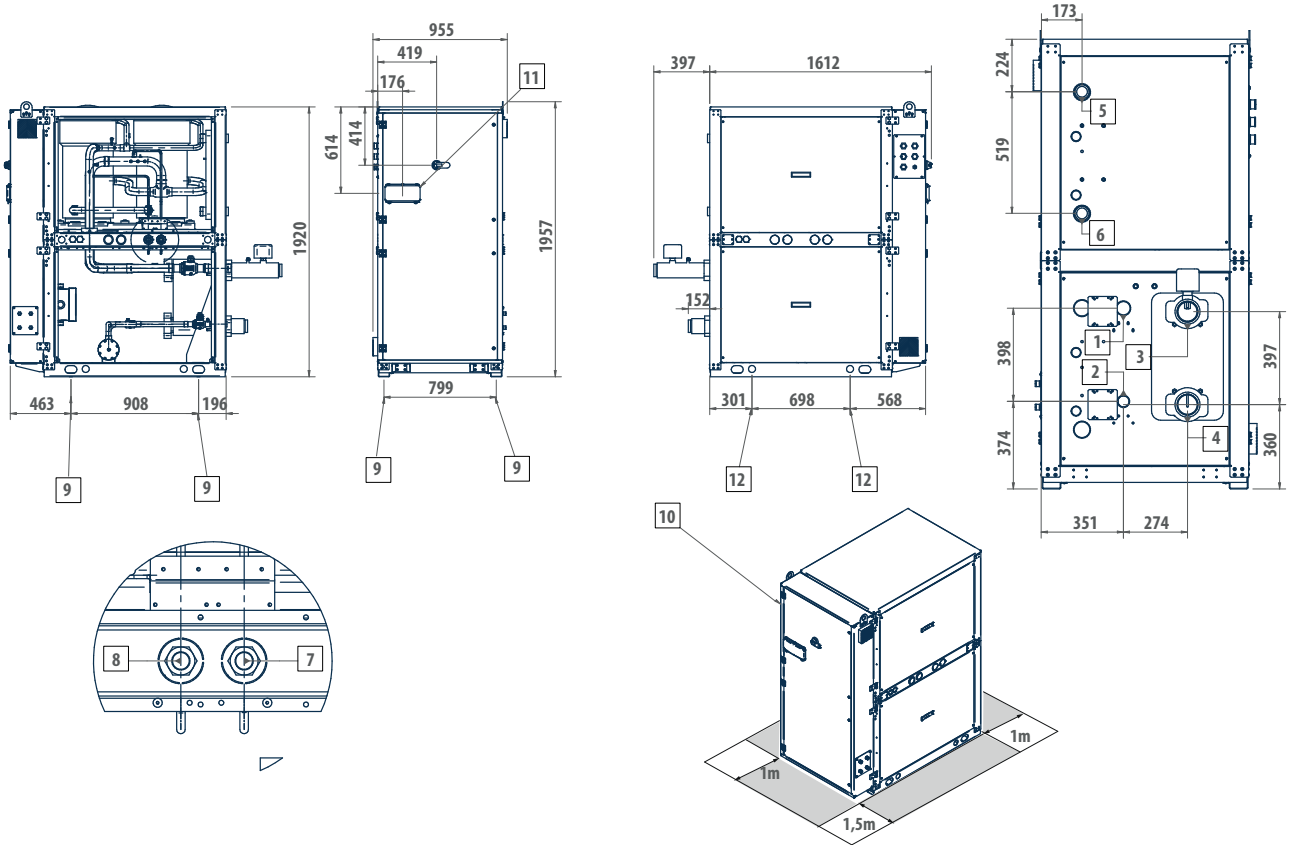

LEGEND

- | | |
|----|---|
| 1 | Refrigerant outlet |
| 2 | Refrigerant return |
| 3 | User side - inlet (Victaulic 3") |
| 4 | User side - outlet (Victaulic 3") |
| 5 | De-superheater water outlet 2" |
| 6 | Desuperheater water inlet 2" |
| 7 | Low pressure safety valve outlet G. 3/4" F |
| 8 | High-pressure relief valve outlet G. 3/4" F |
| 9 | Vibration dumpers |
| 10 | Power supply input |
| 11 | User interface |
| 12 | Lifting points |

CLOSING PANELLING AVAILABLE ON REQUEST

DIMENSIONAL DRAWINGS

LRE 314 - 384

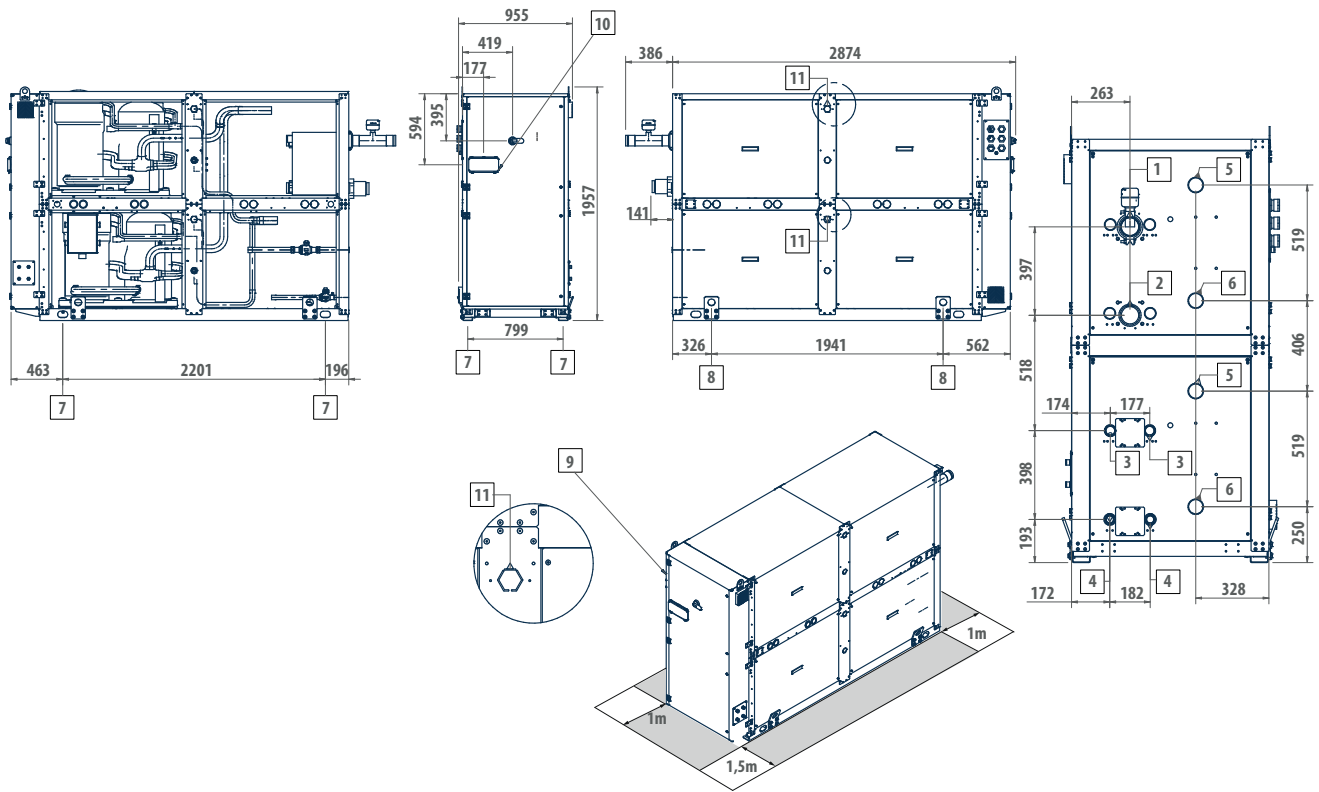

LEGEND

1	User side - inlet (Victaulic 3")
2	User side - outlet (Victaulic 3")
3	Refrigerant outlet
4	Refrigerant return
5	De-superheater water outlet 2"
6	Desuperheater water inlet 2"
7	Vibration dumpers
8	Lifting points
9	Power supply input
10	User interface
11	Outlet safety valve G. 1" F

CLOSING PANNELLING AVAILABLE ON REQUEST

LRE	314	364	384
3) Ø	35	35	35
4) Ø	28	28	28

Motor-driven evaporating units LRE

DIMENSIONAL DRAWINGS

LRE 454 - 564

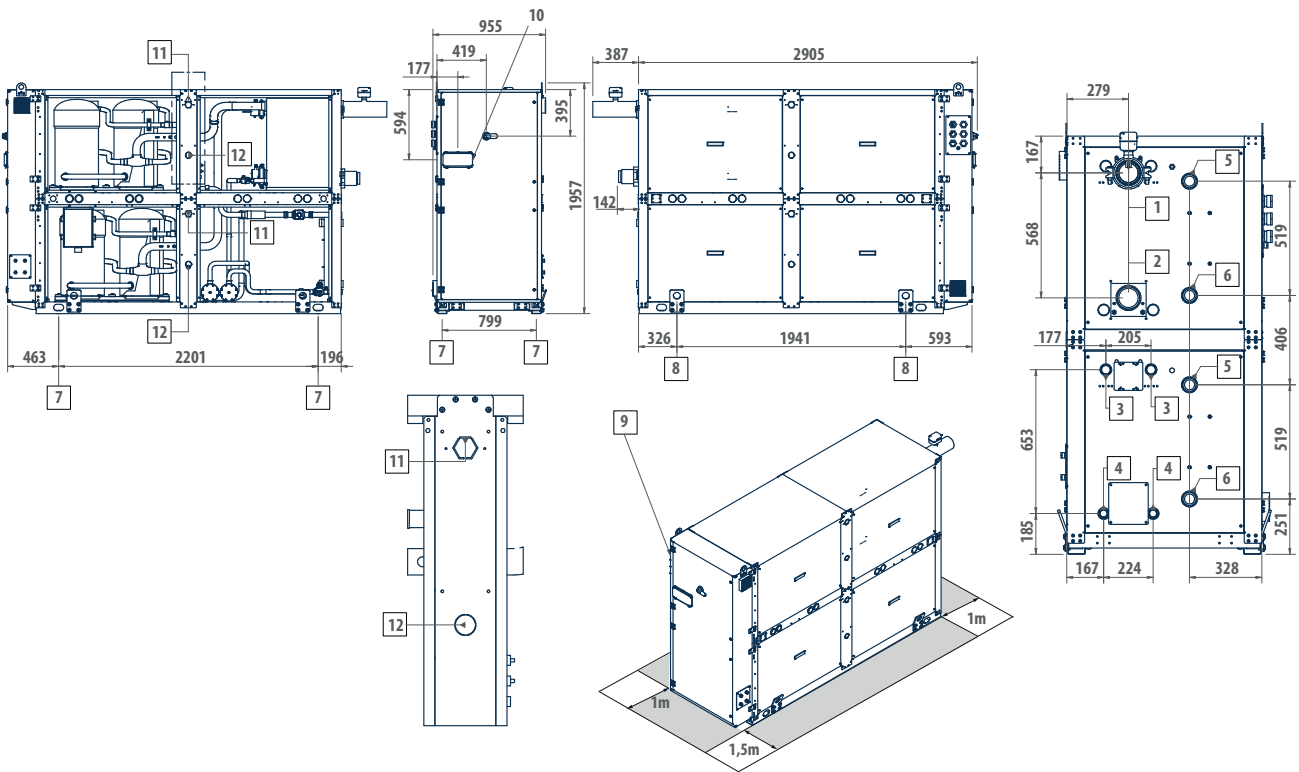

LEGEND

1	User side - inlet (Victaulic 4")
2	User side - outlet (Victaulic 4")
3	Refrigerant outlet
4	Refrigerant return
5	De-superheater water outlet 2"
6	Desuperheater water inlet 2"
7	Vibration dumpers
8	Lifting points
9	Power supply input
10	User interface
11	Low pressure safety valve outlet LRE 454-504 G. 1" F; LRE 564 G. 3/4" F
12	High-pressure relief valve outlet LRE 564 G. 1" M

CLOSING PANNELLING AVAILABLE ON REQUEST

LRE	454	504	564
3) Ø	42	42	42
4) Ø	35	35	35

DIMENSIONAL DRAWINGS

LRE 606 - 746

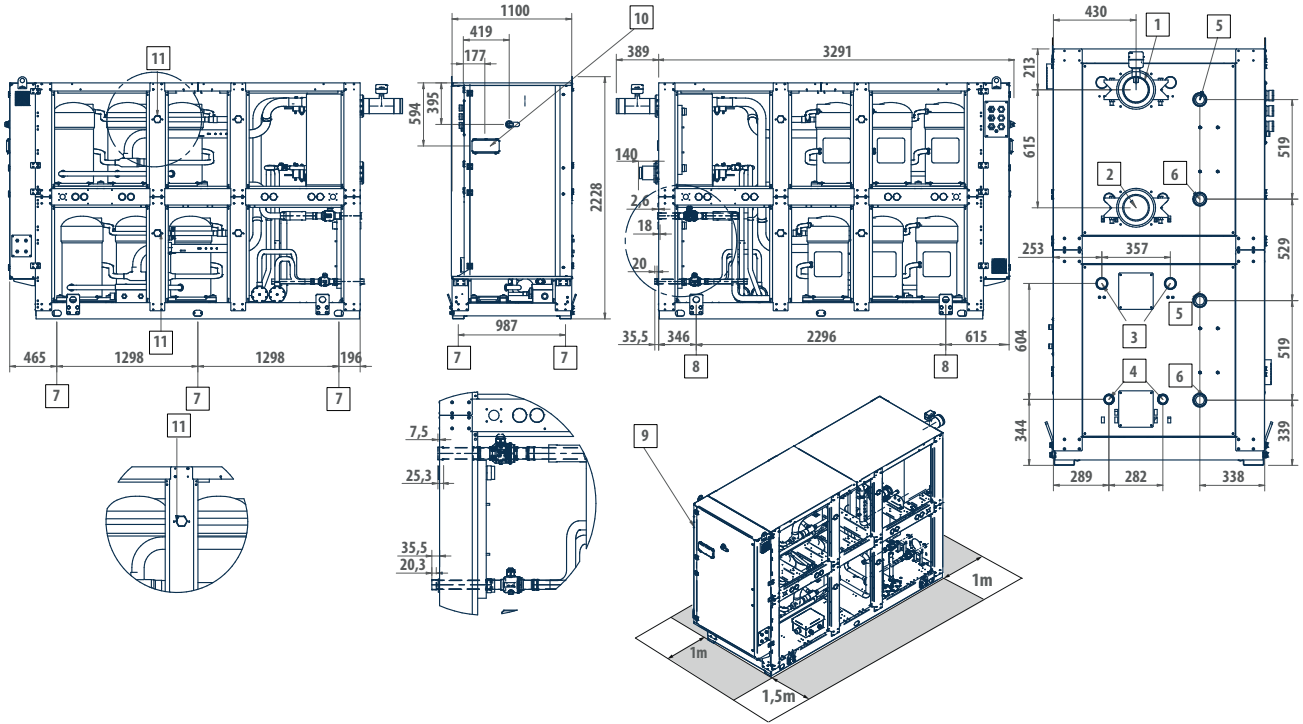

LEGEND

1	User side - inlet (Victaulic 5")
2	User side - outlet (Victaulic 5")
3	Refrigerant outlet
4	Refrigerant return
5	De-superheater water outlet 2"
6	Desuperheater water inlet 2"
7	Vibration dumpers
8	Lifting points
9	Power supply input
10	User interface
11	Outlet safety valve G. 1" 1/4 F

CLOSING PANNELLING AVAILABLE ON REQUEST

LRE	606	636	696	746
3) Ø	42	54	54	54
4) Ø	42	42	42	42



WW - WATER CHILLERS AND HEAT PUMPS

Introduction	p.306
MCW	p.308
WRE	p.314
WLE	p.330



Water chillers and heat pumps

GEO THERMAL ENERGY

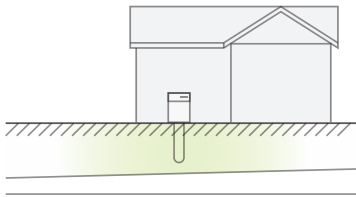

HYDROTHERMAL ENERGY

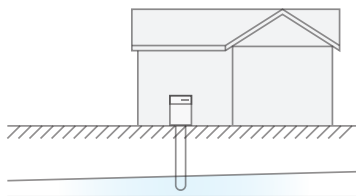

A complete offer ranging from 5 to 700 kW, which adapts to every type of source

The possibility of using water to receive condensation heat from a chilling unit or using water as an energy source for a heat pump, represents an important opportunity to achieve high seasonal and nominal energy performances. Compared to air, in fact, the temperature of the water from an aquifer, well or watercourse is characterised by significantly lower values in summer and higher values in winter and, in general, by slight variations when functioning during the different seasons. Galletti's range of MCW and WRE chillers and heat pumps have been designed to exploit this opportunity more efficiently and various versions of the units are available to better adapt to different types of installations. Water chillers are also used combined with a dry cooler, where it is not possible to install an air unit for lack of space or for the presence of structures that are not able to support its weight.



An efficiency pack for every application

To respond to the different installation requirements in the air conditioning market means being able to propose ad hoc technical solutions where the main features are optimised each time, according to the specific project.

The philosophy underlying the Efficiency Pack adopted on Galletti's range of water-cooled chillers aims to provide systems that focus on reliability and redundancy through bi-circuit solutions or part-load efficiency through tandem or trio solutions. In the first case, the continuity of the supply of power to the system is in fact guaranteed by the presence of independent circuits and continues to operate when the machine comes to a partial stop. In the second case, however, the presence of several compressors connected in parallel to the same cooling circuit allows to achieve a high degree of efficiency under part-load conditions.



High power density

The footprint represents a key feature for units installed inside equipment compartments. The design philosophy which characterises Galletti's water-water units takes this aspect into account, favouring a compact size by choosing smaller components without overlooking efficiency and reliability.

The scroll compressors and the plate heat exchangers fully comply with these criteria, while the careful positioning of the water connections to the system, helps minimising the space required and installation costs.

Versatility in every application

The different water temperatures needed to allow condensation heat to dissipate require ad hoc sizings of the plate heat exchangers involved. Whether the units use water from a well or aquifer, or whether the units are to be connected to a dry-cooler or an evaporating tower, from the range of Galletti products it is possible to choose the version that better meets the system requirements.



Indoor packaged unit

MCW 5 - 39 kW



Compact single circuit units

MCW heat pumps are designed for residential and light-duty commercial environments, and in some cases for industrial applications, process industries and geothermal energy. The entire range is built with a structure and base made of galvanised sheet panelling in epoxy-polyester paint finish, RAL7035, and there is the possibility of choosing an efficient sound absorbing material which, together with the adoption of scroll type compressors, ensure that the units are exceptionally silent and compact.

With an attractive design, a small footprint, the possibility to fit the units with a hydraulic kit complete with circulation pump, expansion tank and buffer tank, means that the machines can even be installed in environments not involved in residential applications.

The design philosophy has favoured the development of units having a reduced height with water connections placed on the upper part, which reduce installation time and costs and the need for technical space.

The MCW series offers a wide range of configurations in terms of accessories available and consists of a large number of sizes, including several single-phase models, each available as a low noise version, in order to fully respond to all system requirements. Only top quality products are used for the cooling, hydraulic and electric systems guaranteeing high technical level of the MCW heat pumps in terms of efficiency, reliability and reduced noise levels.



Scroll compressor



Cooling only



Heating/
Cooling



Rotary compressor



Refrigerant
R-407C

PLUS

- » Easy installation and compact dimensions
- » Scroll compressor
- » Built-in hydronic units
- » Wide range of available accessories

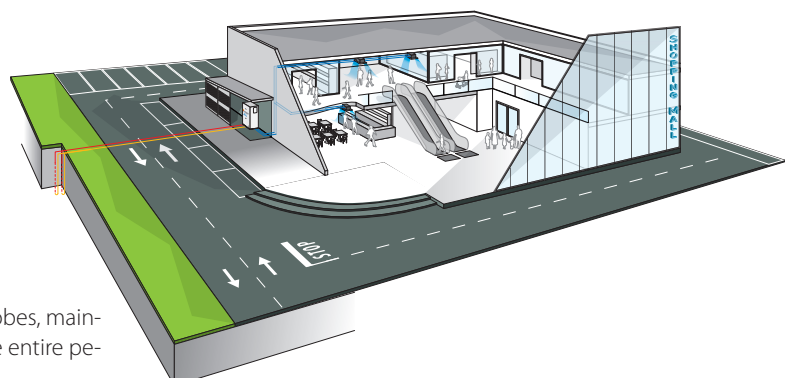

The possibility to dissipate into the aquifer or soil using probes, maintains the original performance of the MCW unit during the entire period of use.

MAIN COMPONENTS

Structure

The structure is in galvanised steel sheet, which is resistant to corrosive agents. Closed equipment compartments are accessible on three sides thanks to easily removable panels with internal sound-proofing insulation.

Compressor

Hermetic scroll compressor powered by a single or three-phase asynchronous motor. It is fixed to the base with rubber vibration dampers.

Heat exchangers

Brazed-welded plate condenser and evaporator in AISI 316 austenitic stainless steel, specifically developed to maximise heat exchange coefficients between water and refrigerant.



Microprocessor control

The microprocessor control has complete management of the MCW units and, because it is highly customisable, it allows to adapt and improve its functioning in every application.

Hydraulic kit

It consists of a centrifugal circulating pump powered by an asynchronous electric motor capable of providing a suitable available head under operating conditions. Also included are an expansion tank and an automatic filling tap.

CONFIGURATOR

The models are completely configurable by selecting the version and the options. To the right is shown an example of configuration.

Version	Field	1	2	3	4	5	6	7	8	9	10	11	12	13	14	15
MCW039HSP		1	0	C	2	0	0	0	0	0	0	G	0	0	0	0

To verify the compatibility of the options, use the selection software or the price list.

AVAILABLE VERSIONS

Reversible heat pump versions
MCW..HSP
MCW..HLP

Standard execution
 Low noise execution

CONFIGURATION OPTIONS

1 Refrigerant - Power supply

- 0 R407C - 230 V - 1 - 50 Hz
- 1 R407C - 400 V - 3 N - 50 Hz
- 2 R407C - 400 V - 3 - 50 Hz

2 Onboard controller and expansion valve

- 0 Basic + mechanical expansion valve
- 3 Source water flow modulation**
- 0 Absent
- C Water flow adjustment valve onboard

4 Water pump and tank

- 0 Absent
- 1 LP pump + expansion vessel
- 2 LP pump + expansion vessel + water tank

5 Remote control / Serial communication

- 0 Absent
- 2 RS485 serial board (Carel / Modbus protocol)

6 Refrigerant pipework accessories

- 0 Absent
- M Refrigerant pressure gauges

7 Compressors options

- 0 Absent

8 Plate water condenser

- 0 Oversized water plate condenser for cooling tower/dry cooler

9 Remote control

- 0 Absent
- S Remote simplified user panel

10 Packing

- 0 Standard
- 1 Wooden cage
- 2 Wooden crate

11 Anti vibration shock mounts

- 0 Absent
- G Rubber anti vibration shock mounts

Water chillers and heat pumps MCW

MCW H RATED TECHNICAL DATA

MCW H		V-ph-Hz	005M	007M	010	010M	012	015	018
Power supply		V-ph-Hz	230 - 1 - 50	230 - 1 - 50	400 - 3N - 50	230 - 1 - 50	400 - 3N - 50	400 - 3N - 50	400 - 3N - 50
Cooling capacity	(1)(E)	kW	5,20	6,40	9,10	9,10	11,0	13,7	16,1
Total power input	(1)(E)	kW	1,50	2,10	2,70	2,80	3,30	4,00	4,70
EER	(1)(E)		3,36	3,03	3,33	3,27	3,32	3,44	3,45
SEER	(2)(E)		2,91	2,72	3,07	3,02	3,10	3,25	3,30
Water flow user side	(1)	l/h	896	1100	1577	1567	1901	2355	2779
Water pressure drop user side	(1)(E)	kPa	24	26	23	23	26	23	25
Water flow source side	(1)	l/h	1146	1439	2025	2021	2442	3008	3544
Water pressure drop source side	(1)(E)	kPa	30	43	29	29	42	28	42
Available pressure head user side - LP pumps	(1)	kPa	92	85	78	79	148	148	140
Heating capacity	(3)(E)	kW	5,40	6,90	9,50	9,70	11,7	14,2	17,3
Total power input	(3)(E)	kW	1,70	2,30	3,00	3,10	3,60	4,40	5,10
COP	(3)(E)		3,11	3,02	3,16	3,17	3,25	3,27	3,41
SCOP	(2)(E)		4,01	3,95	4,24	4,23	4,22	4,22	4,35
Heating energy efficiency class	(4)(E)		A++						
Water flow user side	(3)	l/h	939	1201	1645	1687	2024	2467	2996
Water pressure drop user side	(3)(E)	kPa	21	31	20	21	30	20	31
Water flow source side	(3)	l/h	1092	1380	1918	1970	2392	2916	3606
Water pressure drop source side	(3)(E)	kPa	35	39	33	34	39	34	40
Available pressure head user side - LP pumps	(3)	kPa	82	75	67	67	130	124	132
Maximum current absorption		A	12,0	15,0	7,00	23,0	10,0	13,0	14,0
Start up current		A	47	61	46	100	50	66	74
Compressors / circuits			1 / 1						
Expansion vessel volume		dm ³	1	1	1	1	5	5	5
Buffer tank volume		dm ³	47	47	47	47	92	92	92
Sound power level	(5)	dB(A)	55	55	59	59	61	61	61
Sound power level, low-noise version	(5)	dB(A)	53	53	57	57	59	59	59
Transport weight unit with pump and tank		kg	141	144	147	147	173	175	182
Operating weight unit with pump and full tank		kg	176	178	181	181	235	270	289

(1) Water temperature - user side 12°C / 7°C, water temperature - dissipation side 30°C / 35°C (EN14511:2022)

(2) η efficiency values for heating and cooling are respectively calculated by the following formulas: [$\eta = SCOP / 2,5 - F(1) - F(2)$] e [$\eta = SEER / 2,5 - F(1) - F(2)$]. For further information, please refer to the technical document "ErP 2009/125/EC DIRECTIVE" in the catalogue introducing pages, or to the EN14825:2022 regulation.

(3) Water temperature - user side 40°C / 45°C, water temperature - source side 10°C / 7°C (EN14511:2022)

(4) Seasonal energy efficiency class for LOW TEMPERATURE room heating under AVERAGE climatic conditions [EUROPEAN REGULATION No 811/2013. The energy efficiency class of this product is included in the range A+++ → D]

(E) EUROVENT certified data

MCW H RATED TECHNICAL DATA

MCW H			020	022	027	031	039
Power supply		V-ph-Hz	400 - 3N - 50				
Cooling capacity	(1)(E)	kW	18,9	19,9	24,4	28,3	34,9
Total power input	(1)(E)	kW	5,20	5,90	7,40	8,70	10,7
EER	(1)(E)		3,63	3,39	3,30	3,25	3,25
SEER	(2)(E)		3,50	3,29	3,22	3,20	3,22
Water flow user side	(1)	l/h	3252	3418	4207	4867	6014
Water pressure drop user side	(1)(E)	kPa	23	24	21	24	23
Water flow source side	(1)	l/h	4105	4376	5426	6290	7773
Water pressure drop source side	(1)(E)	kPa	35	42	35	49	49
Available pressure head user side - LP pumps	(1)	kPa	122	158	151	139	149
Heating capacity	(3)(E)	kW	19,3	21,1	26,0	30,3	37,5
Total power input	(3)(E)	kW	5,60	6,30	8,10	9,40	11,4
COP	(3)(E)		3,44	3,33	3,22	3,23	3,28
SCOP	(2)(E)		4,67	4,44	4,27	4,90	4,79
Heating energy efficiency class	(4)(E)		A+++	A++	A++	A+++	A+++
Water flow user side	(3)	l/h	3343	3654	4504	5249	6506
Water pressure drop user side	(3)(E)	kPa	24	30	25	35	36
Water flow source side	(3)	l/h	4028	4350	5283	6174	7697
Water pressure drop source side	(3)(E)	kPa	34	37	32	37	36
Available pressure head user side - LP pumps	(3)	kPa	115	127	113	89	132
Maximum current absorption		A	16,0	17,0	20,0	29,0	32,0
Start up current		A	101	98	130	130	135
Compressors / circuits			1 / 1				
Expansion vessel volume		dm ³	5	5	5	5	5
Buffer tank volume		dm ³	92	92	92	92	92
Sound power level	(5)	dB(A)	61	62	62	65	65
Sound power level, low-noise version	(5)	dB(A)	60	60	60	63	63
Transport weight unit with pump and tank		kg	225	259	271	286	297
Operating weight unit with pump and full tank		kg	292	295	307	322	348

- (1) Water temperature - user side 12°C / 7°C, water temperature - dissipation side 30°C / 35°C (EN14511:2022)
 (2) η efficiency values for heating and cooling are respectively calculated by the following formulas: $[\eta = SCOP / 2,5 - F(1) - F(2)]$ e $[\eta = SEER / 2,5 - F(1) - F(2)]$. For further information, please refer to the technical document "ErP 2009/125/EC DIRECTIVE" in the catalogue introducing pages, or to the EN14825:2022 regulation.
 (3) Water temperature - user side 40°C / 45°C, water temperature - source side 10°C / 7°C (EN14511:2022)
 (4) Seasonal energy efficiency class for LOW TEMPERATURE room heating under AVERAGE climatic conditions [EUROPEAN REGULATION No 811/2013. The energy efficiency class of this product is included in the range A+++ → D]
 (E) EUROVENT certified data

DIMENSIONAL DRAWINGS

MCW 005 - 010

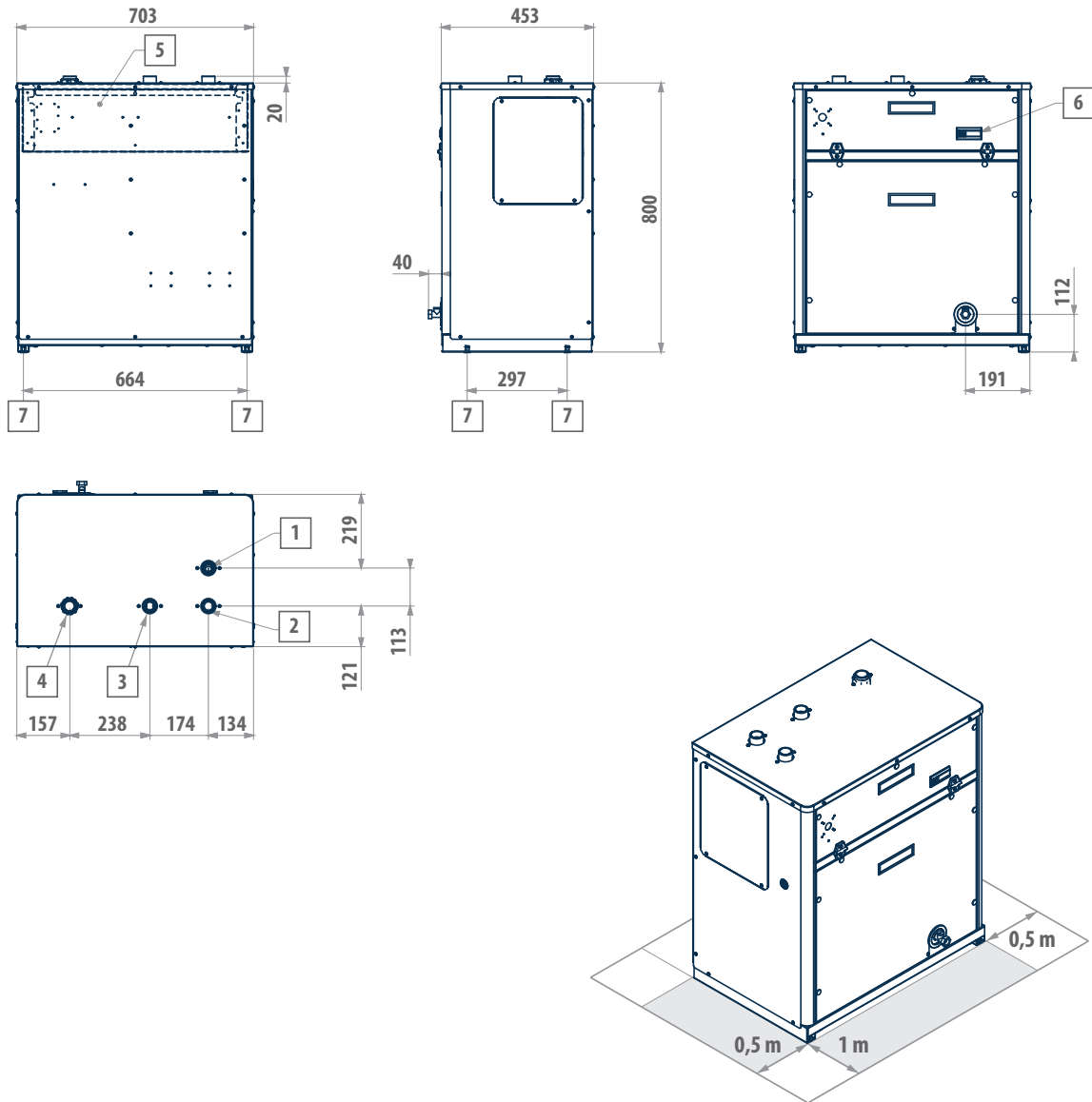

LEGEND

1	Condenser water inlet (1 ¼" gas)
2	Condenser water outlet (1 ¼" gas)
3	Evaporator water inlet (1 ¼" gas)
4	Evaporator water outlet (1 ¼" gas)
5	Electric control board
6	Microprocessor control
7	Vibration dampers

DIMENSIONAL DRAWINGS

MCW 012 - 039

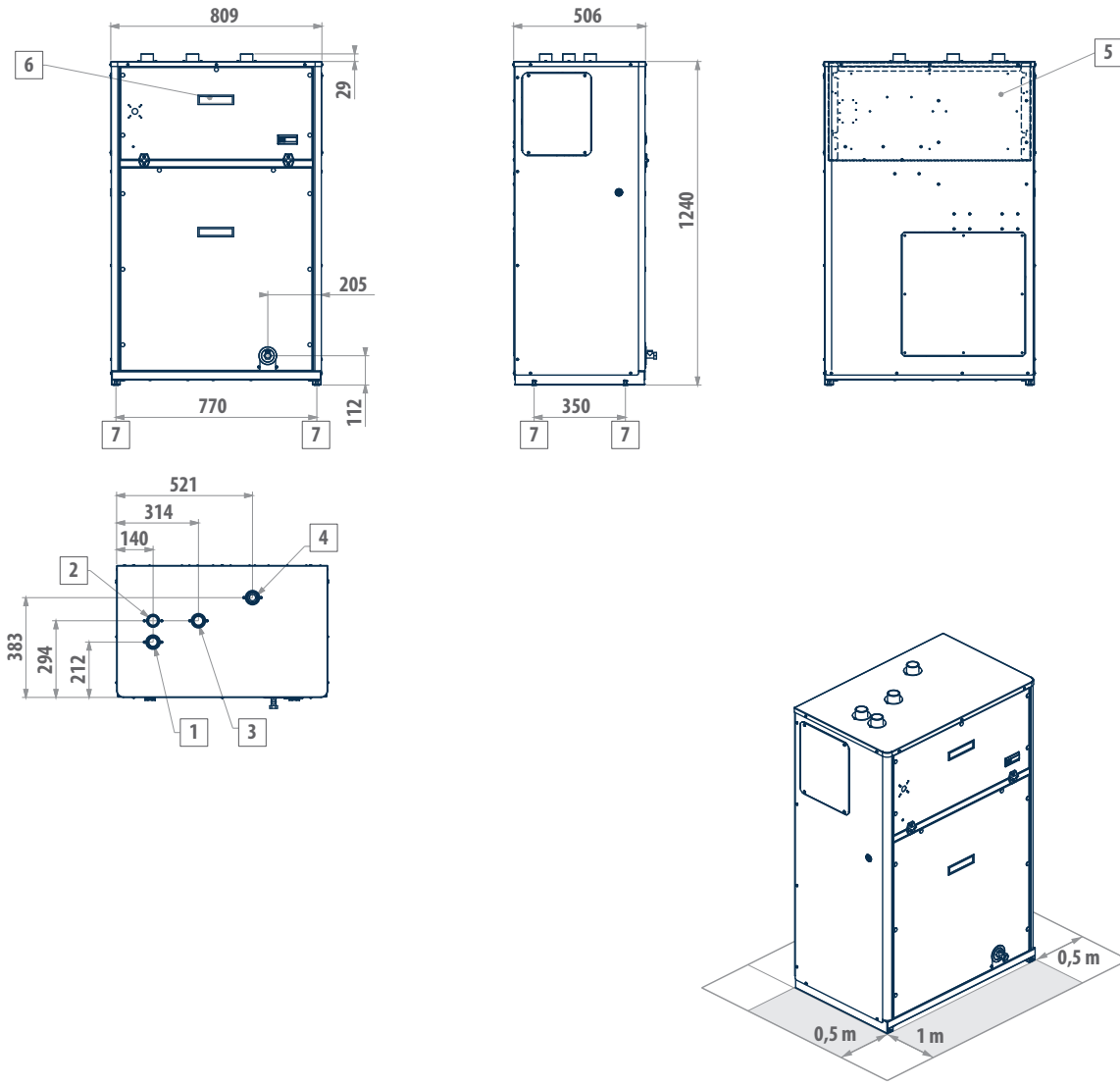

LEGEND

1	Condenser water inlet (1 ¼" gas)
2	Condenser water outlet (1 ¼" gas)
3	Evaporator water inlet (1 ¼" gas)
4	Evaporator water outlet (1 ¼" gas)
5	Electric control board
6	Microprocessor control
7	Vibration dampers

Indoor packaged unit

WRE 40 - 750 kW



Scroll
compressor



Refrigerant
R-410A



Cooling only



Heating/
Cooling

PLUS

- » Electronic expansion valve
- » Up to 6 compressors
- » 1 or 2 cooling circuits
- » Remote connectivity with the most common protocols
- » Compact dimensions
- » 3 different acoustic configurations
- » High seasonal efficiency values

Water-water unit with high seasonal efficiency

WRE is the new Galletti series of self-contained reversible heat pumps and water chillers for indoor installation, suitable for both air conditioning and industrial process applications. The range covers capacities from 40 kW up to a maximum of 750 kW and is characterised by extremely high levels of seasonal efficiency (in compliance with ErP 2021 requirements) and reduced space requirements in order to facilitate access to technical compartments (for capacities of up to 560 kW, the width and height are less than 96 cm and 196 cm respectively). In order to increase the efficiency at partial loads, WRE models are provided with tandem or trio solutions (2 or 3 compressors on a single circuit) and equipped with electronic expansion valve as standard. Both single and dual circuit versions are available.

The use of top quality components at the cutting edge of technology in cooling, hydraulic, and electrical systems makes WRE chillers state of the art in terms of efficiency, reliability, and operating limits. In fact, the ability to produce water from -8 °C to 55 °C and use any type of natural source for dissipation is guaranteed: soil, ground water, or outside air.

The high configurability of the series, which is in the DNA of Galletti, is guaranteed by 2 different versions, with and without closing panels, and 3 different acoustic configurations: standard, low noise, and super low noise, able to ensure a sound power level reduction of up to 12 dB(A).

The range of the configuration available is completed by the possibility of producing hot water up to 60 °C at zero cost through partial heat recovery.

Lastly, the advanced microprocessor that regulates the operation of the unit allows: the control of a maximum of 2 pumps on the equipment side and 2 pumps on the source side, on/off or modulating, the possibility of cascade connection of up to 4 units and management of reversibility on both the gas side and the water side.

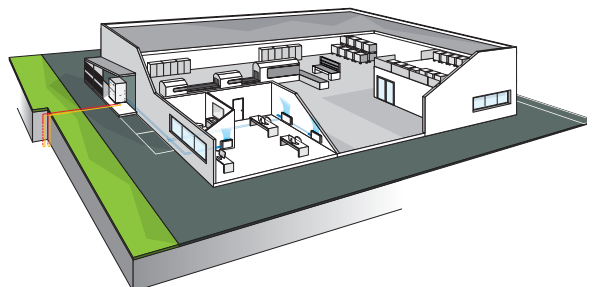

The possibility of keeping the evaporator indoors means there is no need to add glycol to the water inside the system. In addition, you can keep all components requiring maintenance in an easily accessible room.

MAIN COMPONENTS

Structure

Made in galvanised steel sheet with a polyester powder coating for outdoors.

On request the compressor compartment is completely sealed and accessible on 3 sides thanks to easily removable panels that greatly simplify all maintenance and inspection operations.

Compressori scroll

Scroll-type compressors in a tandem or trio configuration equipped with IDV valve. The IDV intermediate delivery valve technology allows the compressor to avoid losses caused by overcompression and, consequently, the additional work the motor has to perform in partial-load operation, saving energy and improving seasonal and partial-load efficiency from 3% to 10%.



Heat exchangers

All units have heat exchangers with braze-welded AISI 316 austenitic stainless steel plates and connections made of AISI 316 L, characterised by a reduced carbon content to facilitate brazing.

Cooling circuit

It can be produced in 2 different versions with the same power rating (Efficiency Pack); using mainly: R410A scroll compressors, brazed plate heat exchangers, and electronic expansion valves.



Electronic microprocessor control

It allows complete management of the unit. The electronic control system allows the setpoint to be adjusted automatically according to the outdoor temperature in order to reduce consumption and broaden the working temperature range. With the advanced microprocessor control it is possible to set up LAN networks for controlling 6 units in parallel.

CONFIGURATOR

The models are completely configurable by selecting the version and the options. To the right is shown an example of configuration.

Version	Field	1	2	3	4	5	6	7	8	9	10
WRE132HL		2	B	0	P	0	1	G	0	0	2

To verify the compatibility of the options, use the selection software or the price list.

AVAILABLE VERSIONS

Only cooling versions

WRE...CSG
WRE...CLG
WRE...CQG

Standard execution
Low noise execution
Super low noise execution

Heat pump versions

WRE...HSG
WRE...HLG
WRE...HQG

Reversible, standard execution
Reversible, low noise execution
Reversible, quiet execution

CONFIGURATION OPTIONS

1 Power supply

- 0 400 - 3 - 50 + N
- 1 400 - 3 - 50
- 2 400 - 3 - 50 + N + circuit breakers
- 3 400 - 3 - 50 + circuit breakers

2 Control microprocessor and lamination device

- B Advanced + electronic expansion valve

3 Partial heat recovery

- 0 Absent
- D Desuperheater (partial heat recovery)

4 Management of source side pumps*

- 1 Single pump
- 2 Dual pump
- 3 Single pump + condensation control with 0-10V modulated output signal
- 4 Dual pump + condensation control with 0-10V modulated output signal

5 User water flow modulation*

- 1 Single pump
- 2 Dual pump
- 3 Single pump + output signal with water flow modulation in ΔT logic = cost
- 4 Dual pump + output signal with water flow modulation in ΔT logic = cost
- 5 Single pump + output signal with water flow modulation in T logic = cost
- 6 Dual pump + output signal with water flow modulation in T logic = cost

6 Remote communication

- 0 Absent
- 1 RS485 serial card (Modbus or Carel protocol)
- 4 Ethernet card (SNMP or BACNET protocol) + clock card
- 5 Ethernet card + clock card + monitoring software

7 Anti vibration shock mounts

- 0 Absent
- G Rubber vibration dampers at the base of the unit
- M Spring vibration dampers at the base of the unit

8 Packing

- 0 Standard
- 1 Wooden cage
- 2 Wooden crate

9 Remote control

- 0 Absent
- 1 Simplified remote control panel
- 3 Remote display for programmable microprocessor

10 Anti-intrusion panelling

- 0 Absent
- P Present (standard for Q version)

*PUMP NOT SUPPLIED

ACCESSORIES

A	Power factor capacitors	I	Two pairs of Victaulic joints
B	Soft starter	L	Filter regulating kit
C	Service kit (advanced controller required)	M	Set point compensation outdoor temperature probe
D	Signal for user side water flow reversal valve management	N	Compressor tandem/trio isolation valves
E	ON/OFF status of the compressors	P	Unit lifting pipes
F	Remote control for step capacity limit (advanced controller required)	Q	Temperature probe for pump shutdown on the primary circuit
G	Configurable digital alarm board (advanced controller required)	T	Mains power analyzer for monitoring and reducing power consumption
H	Refrigerant pressure gauges	V	Set-point modification with 4-20mA signal

Water chillers and heat pumps WRE

RATED TECHNICAL DATA OF WRE C WATER CHILLERS

WRE			052	062	072	082	092	122	132	
Power supply		V-ph-Hz	400 - 3N - 50							
Cooling capacity	(1)(E)	kW	47,1	59,0	68,5	80,5	92,6	119	135	
Total power input	(1)(E)	kW	11,0	13,8	16,1	18,8	21,7	27,7	31,4	
EER	(1)(E)		4,26	4,26	4,26	4,28	4,27	4,31	4,31	
SEER	(2)(E)		5,48	5,71	5,75	5,53	5,84	5,55	5,53	
Water flow user side	(1)	l/h	8112	10158	11807	13864	15946	20510	23312	
Water pressure drop user side	(1)(E)	kPa	50	50	48	49	49	47	47	
Water flow source side	(1)	l/h	9873	12364	14382	16884	19432	24979	28414	
Water pressure drop source side	(1)(E)	kPa	77	77	73	74	75	70	71	
Maximum current absorption		A	29,0	36,0	42,0	49,0	57,0	72,0	81,0	
Start up current		A	112	161	211	218	178	288	296	
Startup current with soft starter		A	67	97	127	131	107	173	178	
Compressors / circuits			2 / 1							
Sound power level	(3)	dB(A)	73	75	76	77	80	80	82	
Sound power level, low-noise version	(3)	dB(A)	67	69	70	71	74	74	76	
Sound power level quiet version	(3)	dB(A)	61	63	64	65	68	68	70	
Transport / operating weight		kg	310	328	343	361	408	560	619	

WRE			152	154	182	184	212	214	242	
Power supply		V-ph-Hz	400 - 3N - 50							
Cooling capacity	(1)(E)	kW	156	149	182	185	215	214	240	
Total power input	(1)(E)	kW	36,2	35,0	41,0	42,6	48,4	48,9	53,3	
EER	(1)(E)		4,32	4,24	4,43	4,34	4,44	4,37	4,51	
SEER	(2)(E)		5,80	5,30	5,83	6,31	5,60	5,95	5,53	
Water flow user side	(1)	l/h	26893	25552	31238	31791	36973	36795	41332	
Water pressure drop user side	(1)(E)	kPa	48	35	39	38	41	41	37	
Water flow source side	(1)	l/h	32772	31290	37948	38779	44903	44808	50098	
Water pressure drop source side	(1)(E)	kPa	74	52	60	58	63	63	57	
Maximum current absorption		A	91,0	90,0	112	114	130	128	151	
Start up current		A	356	224	380	293	399	307	420	
Startup current with soft starter		A	214	153	228	199	239	210	252	
Compressors / circuits			2 / 1	4 / 2	2 / 1	4 / 2	2 / 1	4 / 2	2 / 1	
Sound power level	(3)	dB(A)	87	79	87	83	89	83	89	
Sound power level, low-noise version	(3)	dB(A)	81	73	83	77	84	77	85	
Sound power level quiet version	(3)	dB(A)	75	67	77	71	78	71	79	
Transport / operating weight		kg	688	997	727	932	799	973	869	

(1) Water temperature - user side 12°C / 7°C, water temperature - dissipation side 30°C / 35°C (EN14511:2022)

(2) η efficiency values for heating and cooling are respectively calculated by the following formulas: $[\eta = SCOP / 2,5 - F(1) - F(2)]$ e $[\eta = SEER / 2,5 - F(1) - F(2)]$. For further information, please refer to the technical document "ErP 2009/125/EC DIRECTIVE" in the catalogue introducing pages, or to the EN14825:2022 regulation.

(3) Sound power level measured according to ISO 9614

(E) EUROVENT certified data

RATED TECHNICAL DATA OF WRE C WATER CHILLERS

WRE			244	274	302	314	364	384	454
Power supply		V-ph-Hz	400 - 3N - 50						
Cooling capacity	(1)(E)	kW	238	271	299	314	362	388	457
Total power input	(1)(E)	kW	54,7	62,3	66,8	71,4	82,1	88,0	93,7
EER	(1)(E)		4,35	4,35	4,48	4,40	4,41	4,40	4,88
SEER	(2)(E)		5,96	5,91	5,55	6,22	6,19	5,92	6,50
Water flow user side	(1)	l/h	40957	46553	51448	54021	62227	66617	78600
Water pressure drop user side	(1)(E)	kPa	44	46	44	46	47	47	30
Water flow source side	(1)	l/h	49913	56753	62410	65722	75682	81052	94179
Water pressure drop source side	(1)(E)	kPa	65	68	67	71	71	71	50
Maximum current absorption		A	144	161	166	182	224	240	261
Start up current		A	360	377	510	447	492	508	529
Startup current with soft starter		A	244	259	306	305	340	353	369
Compressors / circuits			4 / 2	4 / 2	2 / 1	4 / 2	4 / 2	4 / 2	4 / 2
Sound power level	(3)	dB(A)	83	85	91	90	90	90	92
Sound power level, low-noise version	(3)	dB(A)	77	79	88	84	86	86	87
Sound power level quiet version	(3)	dB(A)	71	73	82	78	80	80	81
Transport / operating weight		kg	992	1101	1101	1393	1491	1523	1925

WRE			504	564	606	636	696	746	
Power supply		V-ph-Hz	400 - 3N - 50						
Cooling capacity	(1)(E)	kW	511	565	596	643	696	747	
Total power input	(1)(E)	kW	104	118	127	138	148	157	
EER	(1)(E)		4,91	4,80	4,69	4,65	4,70	4,74	
SEER	(2)(E)		6,56	6,52	6,56	6,51	6,53	6,57	
Water flow user side	(1)	l/h	87730	97009	102425	110456	119608	128288	
Water pressure drop user side	(1)(E)	kPa	36	43	43	47	46	47	
Water flow source side	(1)	l/h	104947	116367	123329	133152	143938	154171	
Water pressure drop source side	(1)(E)	kPa	60	70	71	76	75	75	
Maximum current absorption		A	303	317	328	370	412	454	
Start up current		A	571	661	593	638	680	722	
Startup current with soft starter		A	403	460	421	457	491	524	
Compressors / circuits			4 / 2	4 / 2	6 / 2	6 / 2	6 / 2	6 / 2	
Sound power level	(3)	dB(A)	92	93	94	94	94	94	
Sound power level, low-noise version	(3)	dB(A)	88	90	88	89	89	90	
Sound power level quiet version	(3)	dB(A)	82	84	82	83	83	84	
Transport / operating weight		kg	1968	2035	2592	2689	2648	2752	

- (1) Water temperature - user side 12°C / 7°C, water temperature - dissipation side 30°C / 35°C (EN14511:2022)
(2) η efficiency values for heating and cooling are respectively calculated by the following formulas: $[\eta = SCOP / 2,5 - F(1) - F(2)]$ e $[\eta = SEER / 2,5 - F(1) - F(2)]$. For further information, please refer to the technical document "ErP 2009/125/EC DIRECTIVE" in the catalogue introducing pages, or to the EN14825:2022 regulation.
(3) Sound power level measured according to ISO 9614
(E) EUROVENT certified data

Water chillers and heat pumps WRE

RATED TECHNICAL DATA OF WRE H REVERSIBLE HEAT PUMPS

WRE			052	062	072	082	092	122	132
Power supply		V-ph-Hz	400 - 3N - 50						
Cooling capacity	(1)(E)	kW	47,1	58,9	68,5	80,5	92,6	119	135
Total power input	(1)(E)	kW	11,1	13,8	16,1	18,9	21,7	27,7	31,4
EER	(1)(E)		4,25	4,26	4,26	4,27	4,26	4,30	4,31
SEER	(2)(E)		5,48	5,71	5,75	5,53	5,84	5,55	5,53
Water flow user side	(1)	l/h	8122	10147	11798	13874	15946	20512	23307
Water pressure drop user side	(1)(E)	kPa	50	50	48	49	49	47	47
Water flow source side	(1)	l/h	9889	12353	14371	16899	19436	24984	28407
Water pressure drop source side	(1)(E)	kPa	77	77	73	74	75	70	71
Heating capacity	(3)(E)	kW	51,5	64,3	75,1	88,1	101	133	151
Total power input	(3)(E)	kW	14,1	17,4	20,2	23,5	27,2	34,7	39,6
COP	(3)(E)		3,65	3,70	3,72	3,75	3,71	3,83	3,81
Heating energy efficiency class	(4)		A+++						
SCOP	(2)(E)		5,01	5,08	5,11	5,05	5,17	5,06	5,09
Water flow user side	(3)	l/h	8902	11487	13414	15752	18136	23816	27138
Water pressure drop user side	(3)(E)	kPa	68	68	64	65	66	65	65
Water flow source side	(3)	l/h	11092	14517	16962	19943	22903	30323	34543
Water pressure drop source side	(3)(E)	kPa	93	96	93	94	94	96	96
Maximum current absorption		A	29,0	36,0	42,0	49,0	57,0	72,0	81,0
Start up current		A	112	161	211	218	178	288	296
Startup current with soft starter		A	67	97	127	131	107	173	178
Compressors / circuits			2 / 1						
Sound power level	(5)	dB(A)	73	75	76	77	80	80	82
Sound power level, low-noise version	(5)	dB(A)	67	69	70	71	74	74	76
Sound power level quiet version	(5)	dB(A)	61	63	64	65	68	68	70
Transport / operating weight		kg	315	334	353	371	418	572	635

(1) Water temperature - user side 12°C / 7°C, water temperature - dissipation side 30°C / 35°C (EN14511:2022)

(2) η efficiency values for heating and cooling are respectively calculated by the following formulas: [$\eta = SCOP / 2,5 - F(1) - F(2)$] e [$\eta = SEER / 2,5 - F(1) - F(2)$]. For further information, please refer to the technical document "ErP 2009/125/EC DIRECTIVE" in the catalogue introducing pages, or to the EN14825:2022 regulation.

(3) Water temperature - user side 40°C / 45°C, water temperature - source side 10°C / 7°C (EN14511:2022)

(4) Seasonal energy efficiency class for LOW TEMPERATURE room heating under AVERAGE climatic conditions [EUROPEAN REGULATION No 811/2013. The energy efficiency class of this product is included in the range A+++ → D]

(5) Sound power level measured according to ISO 9614

(E) EUROVENT certified data

RATED TECHNICAL DATA OF WRE H REVERSIBLE HEAT PUMPS

WRE			152	154	182	184	212	214	242
Power supply		V-ph-Hz	400 - 3N - 50						
Cooling capacity	(1)(E)	kW	156	148	182	185	215	214	240
Total power input	(1)(E)	kW	36,2	35,0	41,0	42,6	48,4	48,9	53,3
EER	(1)(E)		4,31	4,24	4,43	4,34	4,44	4,38	4,51
SEER	(2)(E)		5,80	5,30	5,83	6,31	5,60	5,95	5,53
Water flow user side	(1)	l/h	26895	25545	31235	31789	36961	36787	41326
Water pressure drop user side	(1)(E)	kPa	48	35	39	38	41	41	37
Water flow source side	(1)	l/h	32778	37944	44893	50089	62402	31283	38775
Water pressure drop source side	(1)(E)	kPa	74	60	63	57	67	52	58
Heating capacity	(3)(E)	kW	170	168	194	204	235	236	260
Total power input	(3)(E)	kW	45,2	43,8	53,2	53,4	60,7	61,3	66,8
COP	(3)(E)		3,76	3,84	3,65	3,82	3,87	3,85	3,89
Heating energy efficiency class	(4)		A+++						
SCOP	(2)(E)		5,18	4,92	5,18	5,56	5,14	5,44	5,06
Water flow user side	(3)	l/h	30579	30190	34885	36631	42241	42305	46681
Water pressure drop user side	(3)(E)	kPa	65	49	52	52	57	57	50
Water flow source side	(3)	l/h	38688	38317	43571	46423	53818	53713	59452
Water pressure drop source side	(3)(E)	kPa	93	73	72	75	81	81	72
Maximum current absorption		A	91,0	90,0	112	114	130	128	151
Start up current		A	356	224	380	293	399	307	420
Startup current with soft starter		A	214	153	228	199	239	210	252
Compressors / circuits			2 / 1	4 / 2	2 / 1	4 / 2	2 / 1	4 / 2	2 / 1
Sound power level	(5)	dB(A)	87	79	87	83	87	83	89
Sound power level, low-noise version	(5)	dB(A)	81	73	83	77	84	77	85
Sound power level quiet version	(5)	dB(A)	75	67	77	71	78	71	79
Transport / operating weight		kg	706	1014	746	948	820	991	893

(1) Water temperature - user side 12°C / 7°C, water temperature - dissipation side 30°C / 35°C (EN14511:2022)

(2) η efficiency values for heating and cooling are respectively calculated by the following formulas: [$\eta = SCOP / 2,5 - F(1) - F(2)$] e [$\eta = SEER / 2,5 - F(1) - F(2)$]. For further information, please refer to the technical document "ErP 2009/125/EC DIRECTIVE" in the catalogue introducing pages, or to the EN14825:2022 regulation.

(3) Water temperature - user side 40°C / 45°C, water temperature - source side 10°C / 7°C (EN14511:2022)

(4) Seasonal energy efficiency class for LOW TEMPERATURE room heating under AVERAGE climatic conditions [EUROPEAN REGULATION No 811/2013. The energy efficiency class of this product is included in the range A+++ → D]

(5) Sound power level measured according to ISO 9614

(E) EUROVENT certified data

Water chillers and heat pumps WRE

RATED TECHNICAL DATA OF WRE H REVERSIBLE HEAT PUMPS

WRE			244	274	302	314	364	384	454
Power supply		V-ph-Hz	400 - 3N - 50						
Cooling capacity	(1)(E)	kW	238	271	299	314	362	388	457
Total power input	(1)(E)	kW	54,7	62,3	66,8	71,4	82,1	88,0	93,7
EER	(1)(E)		4,35	4,35	4,48	4,40	4,41	4,40	4,88
SEER	(2)(E)		5,96	5,91	5,55	6,22	6,19	5,92	6,50
Water flow user side	(1)	l/h	40958	46550	51446	54007	62223	66618	78595
Water pressure drop user side	(1)(E)	kPa	44	46	44	46	47	47	30
Water flow source side	(1)	l/h	44790	49915	56749	65705	75683	81057	94186
Water pressure drop source side	(1)(E)	kPa	63	65	68	71	71	71	50
Heating capacity	(3)(E)	kW	263	300	327	347	399	425	493
Total power input	(3)(E)	kW	68,4	78,2	83,3	90,3	103	109	116
COP	(3)(E)		3,85	3,84	3,93	3,84	3,87	3,90	4,25
Heating energy efficiency class	(4)		A+++						
SCOP	(2)(E)		5,41	5,42	5,09	5,55	5,50	5,39	5,95
Water flow user side	(3)	l/h	47109	53836	58708	62288	71491	76255	88389
Water pressure drop user side	(3)(E)	kPa	59	62	60	64	64	63	45
Water flow source side	(3)	l/h	59784	68402	75069	79238	91067	97284	115004
Water pressure drop source side	(3)(E)	kPa	87	91	88	91	92	92	59
Maximum current absorption		A	144	161	166	182	224	240	261
Start up current		A	360	377	510	447	492	508	529
Startup current with soft starter		A	244	259	306	305	340	353	369
Compressors / circuits			4 / 2	4 / 2	2 / 1	4 / 2	4 / 2	4 / 2	4 / 2
Sound power level	(5)	dB(A)	83	85	91	90	90	90	92
Sound power level, low-noise version	(5)	dB(A)	77	79	88	84	86	86	87
Sound power level quiet version	(5)	dB(A)	71	73	82	78	80	80	81
Transport / operating weight		kg	1012	1121	1141	1425	1523	1555	1959

(1) Water temperature - user side 12°C / 7°C, water temperature - dissipation side 30°C / 35°C (EN14511:2022)

(2) η efficiency values for heating and cooling are respectively calculated by the following formulas: $[\eta = SCOP / 2,5 - F(1) - F(2)]$ e $[\eta = SEER / 2,5 - F(1) - F(2)]$. For further information, please refer to the technical document "ErP 2009/125/EC DIRECTIVE" in the catalogue introducing pages, or to the EN14825:2022 regulation.

(3) Water temperature - user side 40°C / 45°C, water temperature - source side 10°C / 7°C (EN14511:2022)

(4) Seasonal energy efficiency class for LOW TEMPERATURE room heating under AVERAGE climatic conditions [EUROPEAN REGULATION No 811/2013. The energy efficiency class of this product is included in the range A+++ → D]

(5) Sound power level measured according to ISO 9614

(E) EUROVENT certified data

RATED TECHNICAL DATA OF WRE H REVERSIBLE HEAT PUMPS

WRE			504	564	606	636	696	746
Power supply		V-ph-Hz	400 - 3N - 50					
Cooling capacity	(1)(E)	kW	510	565	596	643	696	747
Total power input	(1)(E)	kW	104	118	127	138	148	157
EER	(1)(E)		4,91	4,80	4,69	4,65	4,70	4,74
SEER	(2)(E)		6,56	6,52	6,56	6,51	6,53	6,57
Water flow user side	(1)	l/h	87721	97016	102424	110464	119601	128286
Water pressure drop user side	(1)(E)	kPa	35	43	43	47	46	47
Water flow source side	(1)	l/h	104931	116374	123327	133169	143929	154171
Water pressure drop source side	(1)(E)	kPa	60	70	71	76	75	75
Heating capacity	(3)(E)	kW	548	610	644	697	751	807
Total power input	(3)(E)	kW	130	147	157	171	184	196
COP	(3)(E)		4,22	4,15	4,10	4,08	4,08	4,12
Heating energy efficiency class	(4)		A+++					
SCOP	(2)(E)		5,92	5,88	5,97	5,85	5,86	5,88
Water flow user side	(3)	l/h	98259	109416	115479	124926	134660	144717
Water pressure drop user side	(3)(E)	kPa	53	63	63	67	66	67
Water flow source side	(3)	l/h	127862	141965	149123	161213	174027	187468
Water pressure drop source side	(3)(E)	kPa	70	86	85	92	91	93
Maximum current absorption		A	303	317	328	370	412	454
Start up current		A	571	661	593	638	680	722
Startup current with soft starter		A	403	460	421	457	491	524
Compressors / circuits			4 / 2	4 / 2	6 / 2	6 / 2	6 / 2	6 / 2
Sound power level	(5)	dB(A)	92	93	94	94	94	94
Sound power level, low-noise version	(5)	dB(A)	88	90	88	89	89	90
Sound power level quiet version	(5)	dB(A)	82	84	82	83	83	84
Transport / operating weight		kg	2008	2075	2669	2775	2734	2838

- (1) Water temperature - user side 12°C / 7°C, water temperature - dissipation side 30°C / 35°C (EN14511:2022)
(2) η efficiency values for heating and cooling are respectively calculated by the following formulas: [$\eta = SCOP / 2,5 - F(1) - F(2)$] e [$\eta = SEER / 2,5 - F(1) - F(2)$]. For further information, please refer to the technical document "ErP 2009/125/EC DIRECTIVE" in the catalogue introducing pages, or to the EN14825:2022 regulation.
(3) Water temperature - user side 40°C / 45°C, water temperature - source side 10°C / 7°C (EN14511:2022)
(4) Seasonal energy efficiency class for LOW TEMPERATURE room heating under AVERAGE climatic conditions [EUROPEAN REGULATION No 811/2013. The energy efficiency class of this product is included in the range A+++ → D]
(5) Sound power level measured according to ISO 9614
(E) EUROVENT certified data

Water chillers and heat pumps WRE

DIMENSIONAL DRAWINGS

WRE 52 - 92

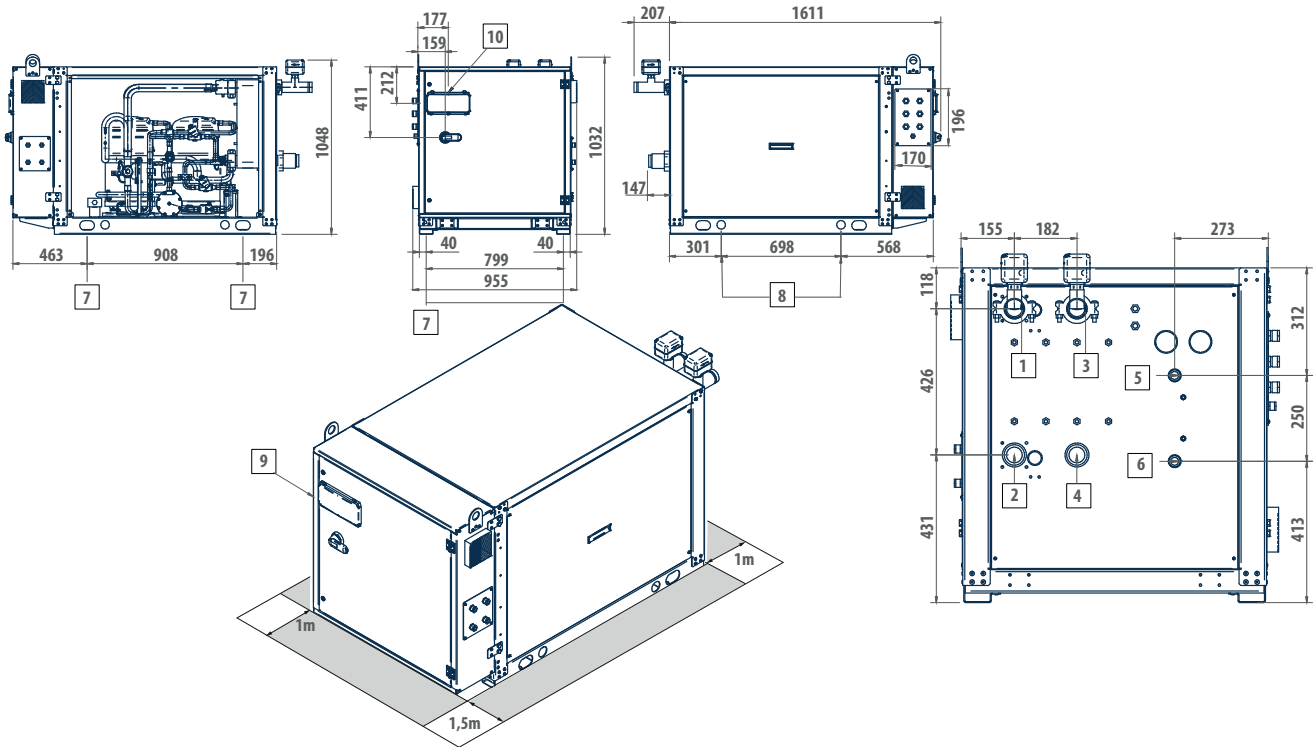

LEGEND WRE C

1	Dissipation side - outlet (Victaulic 2")
2	Dissipation side - inlet Victaulic (Victaulic 2")
3	User side - inlet (Victaulic 2")
4	User side - outlet (Victaulic 2")
5	De-superheater water outlet 1"
6	Desuperheater water inlet 1"
7	Vibration dumpers
8	Lifting points
9	Power supply input
10	User interface

CHILLER FLOW SWITH POSITION: 2-3

CLOSING PANELLING AVAILABLE ON REQUEST

LEGEND WRE H

1	Dissipation side - inlet Victaulic (Victaulic 2")
2	Dissipation side - outlet (Victaulic 2")
3	User side - inlet (Victaulic 2")
4	User side - outlet (Victaulic 2")
5	De-superheater water outlet 1"
6	Desuperheater water inlet 1"
7	Vibration dumpers
8	Lifting points
9	Power supply input
10	User interface

HEAT PUMP FLOW SWITH POSITION: 1-3

CLOSING PANELLING AVAILABLE ON REQUEST

DIMENSIONAL DRAWINGS

WRE 122 - 152

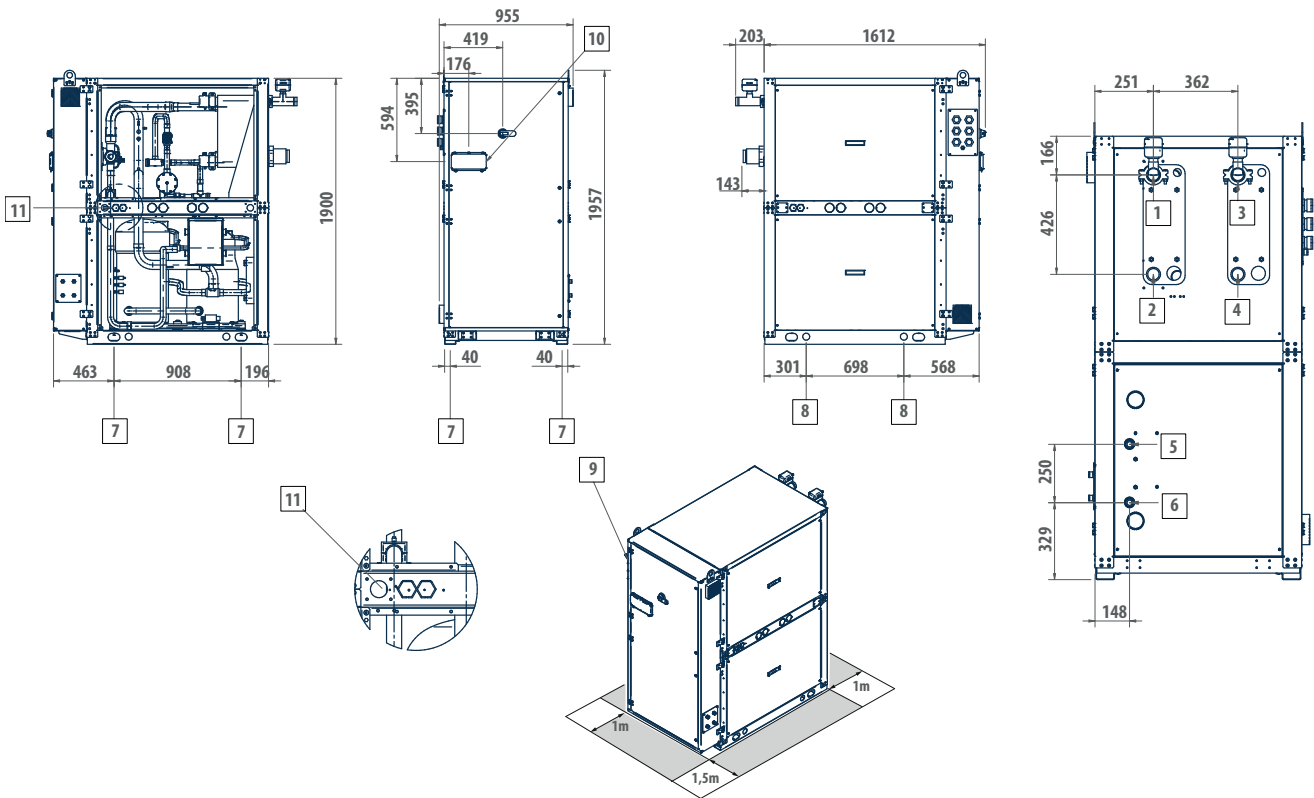

LEGEND WRE C

1	Dissipation side - outlet (Victaulic 2")
2	Dissipation side - inlet Victaulic (Victaulic 2")
3	User side - inlet (Victaulic 2")
4	User side - outlet (Victaulic 2")
5	De-superheater water outlet 1"
6	Desuperheater water inlet 1"
7	Vibration dumpers
8	Lifting points
9	Power supply input
10	User interface
11	Outlet safety valve G. 3/4" F (only 152)

CHILLER FLOW SWITH POSITION: 2-3

CLOSING PANNELLING AVAILABLE ON REQUEST

LEGEND WRE H

1	Dissipation side - inlet Victaulic (Victaulic 2")
2	Dissipation side - outlet (Victaulic 2")
3	User side - inlet (Victaulic 2")
4	User side - outlet (Victaulic 2")
5	De-superheater water outlet 1"
6	Desuperheater water inlet 1"
7	Vibration dumpers
8	Lifting points
9	Power supply input
10	User interface
11	Outlet safety valve G. 3/4" F (only 152)

HEAT PUMP FLOW SWITH POSITION: 1-3

CLOSING PANNELLING AVAILABLE ON REQUEST

Water chillers and heat pumps WRE

DIMENSIONAL DRAWINGS

WRE 182-242

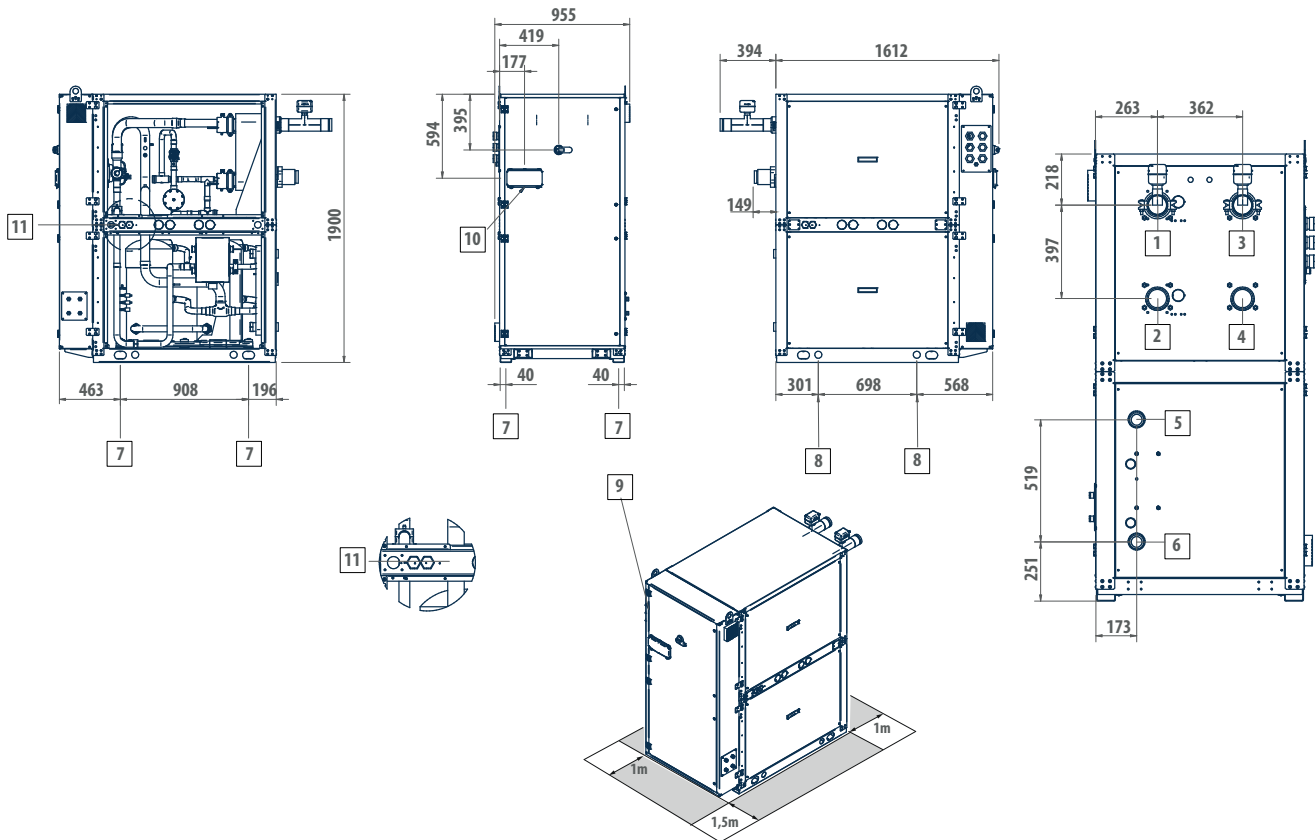

LEGEND WRE C

1	Dissipation side - outlet (Victaulic 3")
2	Dissipation side - inlet (Victaulic 3")
3	User side - inlet (Victaulic 3")
4	User side - outlet (Victaulic 3")
5	De-superheater water outlet 2"
6	Desuperheater water inlet 2"
7	Vibration dumpers
8	Lifting points
9	Power supply input
10	User interface
11	Outlet safety valve G. 3/4" F

CHILLER FLOW SWITH POSITION: 2-3

CLOSING PANELLING AVAILABLE ON REQUEST

LEGEND WRE H

1	Dissipation side - inlet (Victaulic 3")
2	Dissipation side - outlet (Victaulic 3")
3	User side - inlet (Victaulic 3")
4	User side - outlet (Victaulic 3")
5	De-superheater water outlet 2"
6	Desuperheater water inlet 2"
7	Vibration dumpers
8	Lifting points
9	Power supply input
10	User interface
11	Outlet safety valve G. 3/4" F

HEAT PUMP FLOW SWITH POSITION: 1-3

CLOSING PANELLING AVAILABLE ON REQUEST

DIMENSIONAL DRAWINGS

WRE 154-274

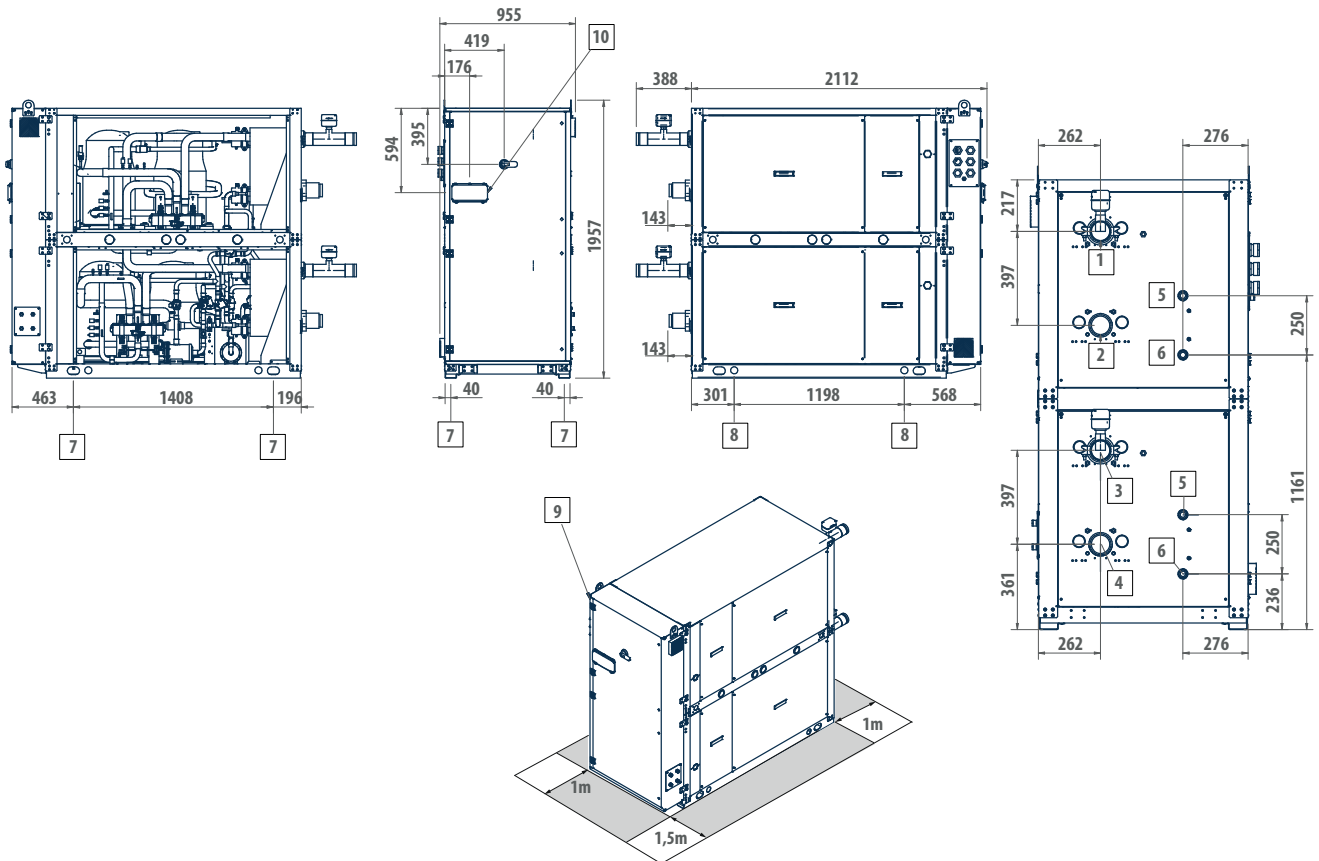

LEGEND WRE C

1	User side - inlet (Victaulic 3")
2	User side - outlet (Victaulic 3")
3	Dissipation side - outlet (Victaulic 3")
4	Dissipation side - inlet (Victaulic 3")
5	De-superheater water outlet 2"
6	Desuperheater water inlet 2"
7	Vibration dumpers
8	Lifting points
9	Power supply input
10	User interface

CHILLER FLOW SWITH POSITION: 1-4

CLOSING PANELLING AVAILABLE ON REQUEST

LEGEND WRE H

1	User side - inlet (Victaulic 3")
2	User side - outlet (Victaulic 3")
3	Dissipation side - inlet (Victaulic 3")
4	Dissipation side - outlet (Victaulic 3")
5	De-superheater water outlet 2"
6	Desuperheater water inlet 2"
7	Vibration dumpers
8	Lifting points
9	Power supply input
10	User interface

HEAT PUMP FLOW SWITH POSITION: 1-3

CLOSING PANELLING AVAILABLE ON REQUEST

Water chillers and heat pumps WRE

DIMENSIONAL DRAWINGS

WRE 302

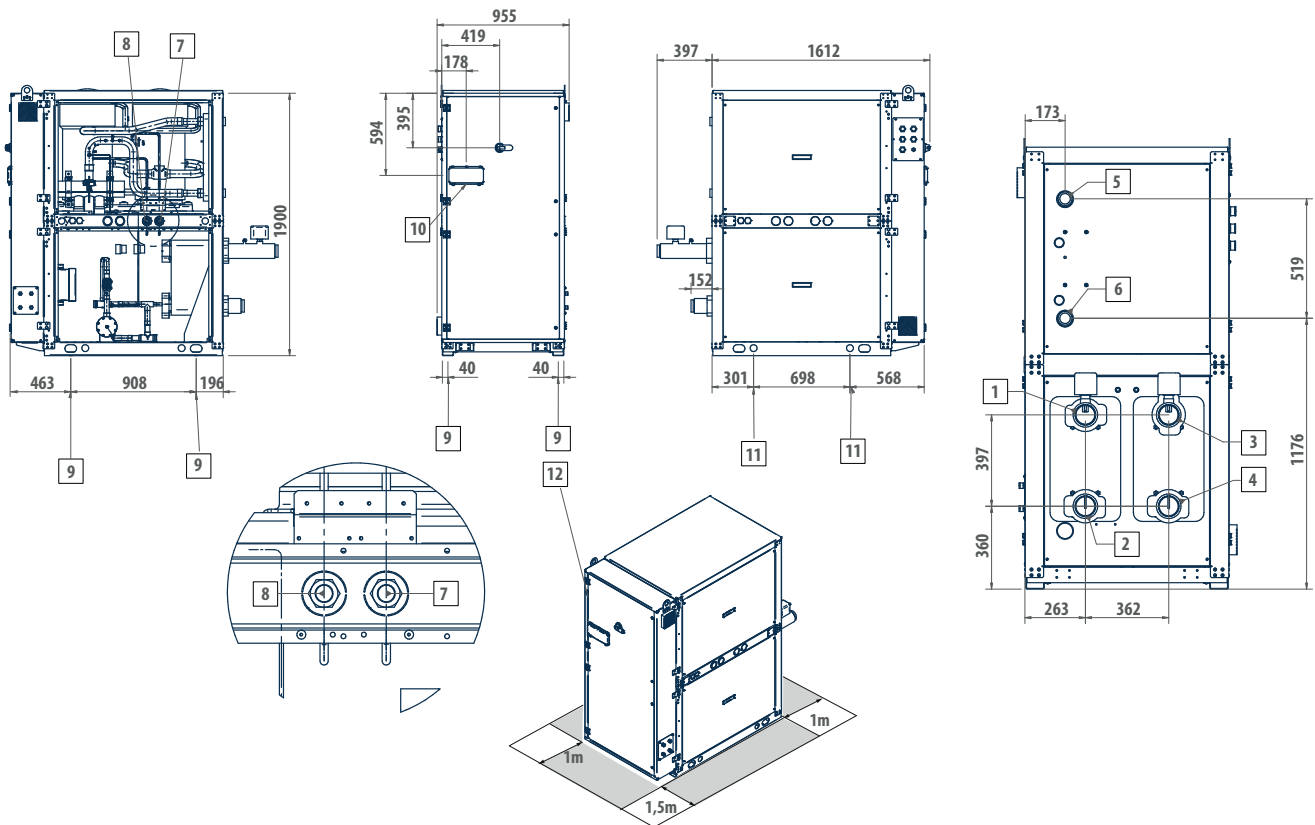

LEGEND WRE C

- | | |
|----|---|
| 1 | Dissipation side - outlet (Victaulic 3") |
| 2 | Dissipation side - inlet (Victaulic 3") |
| 3 | User side - inlet (Victaulic 3") |
| 4 | User side - outlet (Victaulic 3") |
| 5 | Heat exchanger outlet 2" |
| 6 | Heat exchanger inlet 2" |
| 7 | Low pressure safety valve outlet G. 3/4" F |
| 8 | High-pressure relief valve outlet G. 3/4" F |
| 9 | Vibration dumpers |
| 10 | User interface |
| 11 | Lifting points |
| 12 | Power supply input |

CHILLER FLOW SWITH POSITION: 2-3

CLOSING PANELLING AVAILABLE ON REQUEST

LEGEND WRE H

- | | |
|----|---|
| 1 | Dissipation side - inlet (Victaulic 3") |
| 2 | Dissipation side - outlet (Victaulic 3") |
| 3 | User side - inlet (Victaulic 3") |
| 4 | User side - outlet (Victaulic 3") |
| 5 | Heat exchanger outlet 2" |
| 6 | Heat exchanger inlet 2" |
| 7 | Low pressure safety valve outlet G. 3/4" F |
| 8 | High-pressure relief valve outlet G. 3/4" F |
| 9 | Vibration dumpers |
| 10 | User interface |
| 11 | Lifting points |
| 12 | Power supply input |

HEAT PUMP FLOW SWITH POSITION: 1-3

CLOSING PANELLING AVAILABLE ON REQUEST

DIMENSIONAL DRAWINGS

WRE 314 - 384

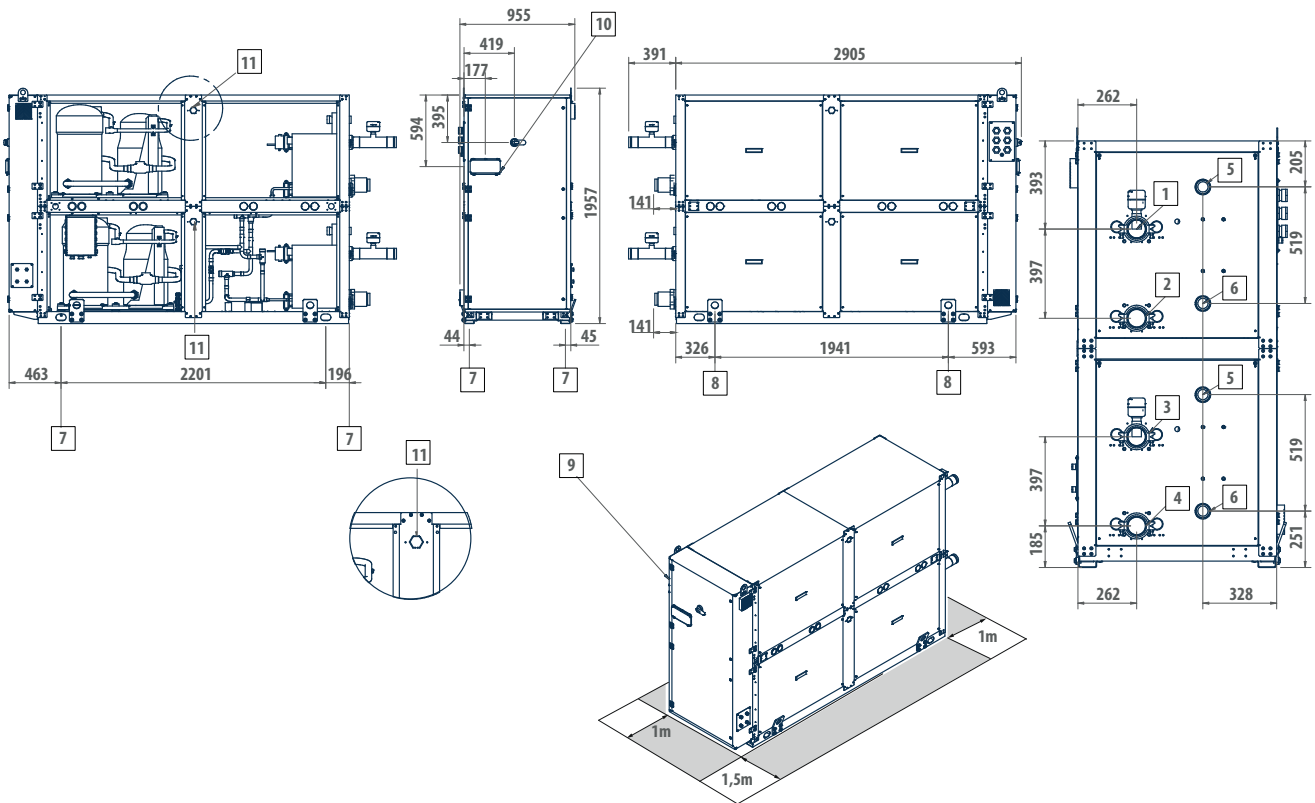

LEGEND WRE C

1	User side - inlet (Victaulic 3")
2	User side - outlet (Victaulic 3")
3	Dissipation side - outlet (Victaulic 3")
4	Dissipation side - inlet (Victaulic 3")
5	De-superheater water outlet 2"
6	Desuperheater water inlet 2"
7	Vibration dumpers
8	Lifting points
9	Power supply input
10	User interface
11	Outlet safety valve G. 1" F

CHILLER FLOW SWITH POSITION: 1-4

CLOSING PANELLING AVAILABLE ON REQUEST

LEGEND WRE H

1	User side - inlet (Victaulic 3")
2	User side - outlet (Victaulic 3")
3	Dissipation side - inlet (Victaulic 3")
4	Dissipation side - outlet (Victaulic 3")
5	De-superheater water outlet 2"
6	Desuperheater water inlet 2"
7	Vibration dumpers
8	Lifting points
9	Power supply input
10	User interface
11	Outlet safety valve G. 1" F

HEAT PUMP FLOW SWITH POSITION: 1-3

CLOSING PANELLING AVAILABLE ON REQUEST

Water chillers and heat pumps WRE

DIMENSIONAL DRAWINGS

WRE 454 - 564

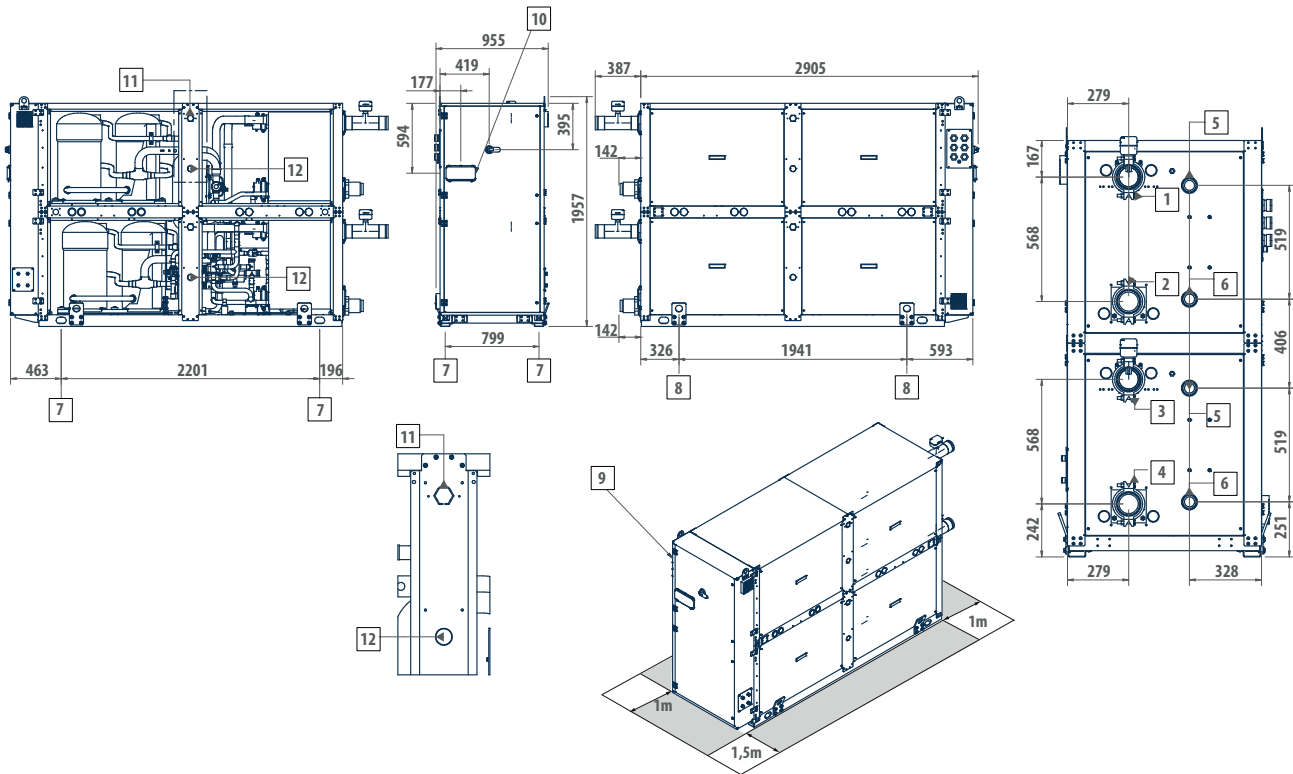

LEGEND WRE C

1	User side - inlet (Victaulic 4")
2	User side - outlet (Victaulic 4")
3	Dissipation side - outlet (Victaulic 4")
4	Dissipation side - inlet (Victaulic 4")
5	De-superheater water outlet 2"
6	Desuperheater water inlet 2"
7	Vibration dumpers
8	Lifting points
9	Power supply input
10	User interface
11	Low pressure safety valve outlet WRE 454-504 G. 1" F; WRE 564 G. 3/4" F
12	High-pressure relief valve outlet WRE 564 G. 1" M

CHILLER FLOW SWITH POSITION: 1-4

CLOSING PANELLING AVAILABLE ON REQUEST

LEGEND WRE H

1	User side - inlet (Victaulic 4")
2	User side - outlet (Victaulic 4")
3	Dissipation side - inlet (Victaulic 4")
4	Dissipation side - outlet (Victaulic 4")
5	De-superheater water outlet 2"
6	Desuperheater water inlet 2"
7	Vibration dumpers
8	Lifting points
9	Power supply input
10	User interface
11	Low pressure safety valve outlet WRE 454-504 G. 1" F; WRE 564 G. 3/4" F
12	High-pressure relief valve outlet WRE 564 G. 1" M

HEAT PUMP FLOW SWITH POSITION: 1-3

CLOSING PANELLING AVAILABLE ON REQUEST

DIMENSIONAL DRAWINGS

WRE 606 - 746

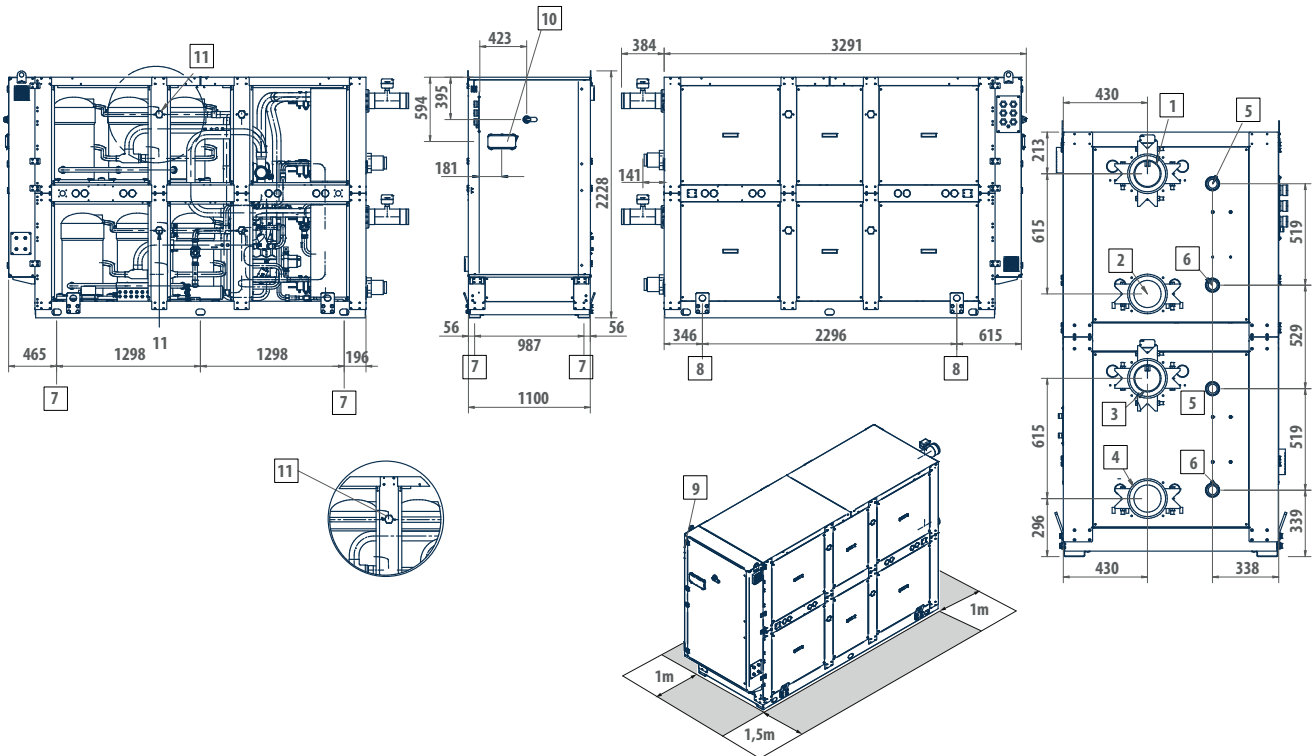

LEGEND WRE C

1	User side - inlet (Victaulic 5")
2	User side - outlet (Victaulic 5")
3	Dissipation side - outlet (Victaulic 5")
4	Dissipation side - inlet (Victaulic 5")
5	De-superheater water outlet 2"
6	Desuperheater water inlet 2"
7	Vibration dumpers
8	Lifting points
9	Power supply input
10	User interface
11	Outlet safety valve G. 1" 1/4 F
CHILLER FLOW SWITH POSITION: 1-4	
CLOSING PANELLING AVAILABLE ON REQUEST	

LEGEND WRE H

1	User side - inlet (Victaulic 5")
2	User side - outlet (Victaulic 5")
3	Dissipation side - inlet (Victaulic 5")
4	Dissipation side - outlet (Victaulic 5")
5	De-superheater water outlet 2"
6	Desuperheater water inlet 2"
7	Vibration dumpers
8	Lifting points
9	Power supply input
10	User interface
11	Outlet safety valve G. 1" 1/4 F
HEAT PUMP FLOW SWITH POSITION: 1-3	
CLOSING PANELLING AVAILABLE ON REQUEST	



Indoor or outdoor packaged unit

WLE 42 kW - 750 kW



Water-cooled packaged units for indoor or outdoor installation with high seasonal efficiency and low-GWP refrigerant

WLE is the new Galletti series of self-contained reversible heat pumps and water chillers for indoor or outdoors (with IP54 electrical panel option) installation, suitable for both air conditioning and industrial process applications. R454B is a next generation A2L refrigerant with a GWP of only 467, one of the lowest on the market. This GWP value ensures that the WLE range complies with the gradual reduction of greenhouse gas emissions required by the F-GAS regulation, down to the stricter limits foreseen for 2030.

The range covers capacities from 40 kW up to a maximum of 750 kW and is characterised by extremely high levels of seasonal efficiency (in compliance with ErP 2021 requirements) and reduced space requirements in order to facilitate access to technical compartments (for capacities of up to 500 kW, the width and height are less than 96 cm and 196 cm respectively). In order to increase the efficiency at partial loads, WLE models are provided with tandem or trio solutions (2 or 3 compressors on a single circuit) and equipped with electronic expansion valve as standard. Both single and dual circuit versions are available.

The use of top quality components at the cutting edge of technology in cooling, hydraulic, and electrical systems makes WLE chillers state of the art in terms of efficiency, reliability, and operating limits. In fact, the ability to produce water from -8 °C to 55 °C and use any type of natural source for dissipation is guaranteed: soil, ground water, or outside air.

The high configurability of the series, which is in the DNA of Galletti, is guaranteed by 2 different versions, with and without closing panels, and 3 different acoustic configurations: standard, low noise, and super low noise, able to ensure a sound power level reduction of up to 12 dB(A). The range of the configuration available is completed by the possibility of producing hot water up to 60 °C at zero cost through partial heat recovery. Lastly, the advanced microprocessor that regulates the operation of the unit allows: the control of a maximum of 2 pumps on the equipment side and 2 pumps on the source side, on/off or modulating, the possibility of cascade connection of up to 6 units and management of reversibility on both the gas side and the water side.

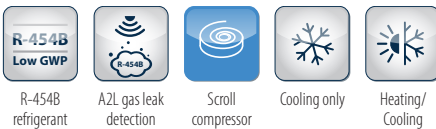

PLUS

- » Refrigerant R454B (GWP=467)
- » Electronic expansion valve
- » Up to 6 compressors
- » 1 or 2 cooling circuits
- » Remote connectivity with the most common protocols
- » Compact dimensions
- » 3 different acoustic configurations
- » High seasonal efficiency values
- » Production of hot water up to 55°C or cold water down to -8 °C

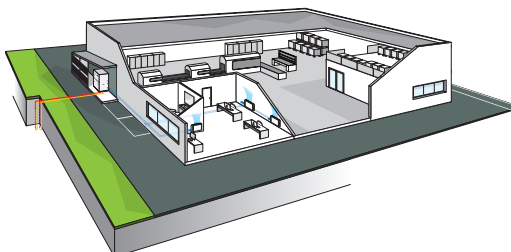

The possibility of keeping the evaporator indoors means there is no need to add glycol to the water inside the system. In addition, you can keep all components requiring maintenance in an easily accessible room.

MAIN COMPONENTS

Structure

Made in galvanised steel sheet with a polyester powder coating for outdoors. On request the compressor compartment is completely sealed and accessible on 3 sides thanks to easily removable panels that greatly simplify all maintenance and inspection operations. The unit can be fitted with electric control board with protection rating IP54 which makes it suitable for outdoor installation.

Compressori scroll

Scroll-type compressors in a tandem or trio configuration equipped with IDV valve. The IDV intermediate delivery valve technology allows the compressor to avoid losses caused by overcompression and, consequently, the additional work the motor has to perform in partial-load operation, saving energy and improving seasonal and partial-load efficiency from 3% to 10%.



Very low GWP refrigerant

Use of R454B refrigerant with low environmental impact. R454B is a next-generation A2L refrigerant with a GWP of only 467, one of the lowest on the market. This GWP value ensures the range complies with the gradual reduction of quotas of greenhouse refrigerants in the European market required by the F-GAS regulation, down to the stricter limits foreseen for 2030

Heat exchangers

All units have heat exchangers with braze-welded AISI 316 austenitic stainless steel plates and connections made of AISI 316 L, characterised by a reduced carbon content to facilitate brazing.



Safety procedures in case of refrigerant leakage

As a standard feature, the units are equipped with leak detection sensors in the electrical control board and near the cooling circuit. The microprocessor manages the procedures for securing and shutting down the unit in case of refrigerant leakage, also making it possible to divert the power supply of the control unit that collects the information from the leak sensors on a low-voltage emergency line. This function allows the complete disconnection of the power to the unit during maintenance operations, while leaving all the safety systems enabled.

CONFIGURATOR

The models are completely configurable by selecting the version and the options. To the right is shown an example of configuration.

Version	Field	1	2	3	4	5	6	7	8	9	10	11
WLE132HL		2	B	0	3	3	1	0	0	0	P	1

To verify the compatibility of the options, use the selection software or the price list.

AVAILABLE VERSIONS

Only cooling versions

WLE...CSG
WLE...CLG
WLE...CQG

Standard execution
Low noise execution
Super low noise execution

Heat pump versions

WLE...HSG
WLE...HLG
WLE...HQG

Reversible, standard execution
Reversible, low noise execution
Reversible, quiet execution

CONFIGURATION OPTIONS

- | | |
|---|--|
| <p>1 Power supply</p> <ul style="list-style-type: none"> 0 400/3/50 + N 1 400/3/50 2 400/3/50 + N + Circuit breakers 3 400/3/50 + circuit breakers <p>2 Control microprocessor and lamination device</p> <ul style="list-style-type: none"> B Advanced + electronic expansion valve <p>3 Partial heat recovery</p> <ul style="list-style-type: none"> 0 Absent D Desuperheater (partial heat recovery) <p>4 Management of source side pumps*</p> <ul style="list-style-type: none"> 1 Single pump 2 Dual pump 3 Single pump + condensation control with 0-10V modulated output signal 4 Dual pump + condensation control with 0-10V modulated output signal <p>5 User water flow modulation*</p> <ul style="list-style-type: none"> 1 Single pump 2 Dual pump 3 Single pump + output signal with water flow modulation in ΔT logic = cost 4 Dual pump + output signal with water flow modulation in ΔT logic = cost 5 Single pump + output signal with water flow modulation in T logic = cost 6 Dual pump + output signal with water flow modulation in T logic = cost <p>6 Remote communication</p> <ul style="list-style-type: none"> 0 Absent | <p>7 RS485 serial card (Modbus or Carel protocol)</p> <ul style="list-style-type: none"> 4 Ethernet card (SNMP or BACNET protocol) + clock card 5 Ethernet card + clock card + monitoring software <p>7 Anti vibration shock mounts</p> <ul style="list-style-type: none"> 0 Absent G Rubber vibration dampers at the base of the unit M Spring vibration dampers at the base of the unit <p>8 Packing</p> <ul style="list-style-type: none"> 0 Standard 1 Wooden cage 2 Wooden crate <p>9 Remote control</p> <ul style="list-style-type: none"> 0 Absent 1 Simplified remote control panel 3 Remote display for programmable microprocessor <p>10 Anti-intrusion panelling</p> <ul style="list-style-type: none"> 0 Absent P Present (standard for Q version and mandatory for field 11 = 1) <p>11 Unit installation</p> <ul style="list-style-type: none"> 0 Indoor 1 Outdoor |
|---|--|

*PUMP NOT SUPPLIED

ACCESSORIES

A	Power factor capacitors	L	Filter regulating kit
B	Soft starter	M	Set point compensation outdoor temperature probe
C	Service kit (advanced controller required)	N	Compressor tandem/trio isolation valves
D	User side water flow reversal valve management	P	Unit lifting pipes
E	ON/OFF status of the compressors	Q	Temperature probe for pump shutdown on the primary circuit
F	Remote control for step capacity limit (advanced controller required)	T	Mains power analyzer for monitoring and reducing power consumption
G	Configurable digital alarm board (advanced controller required)	V	Set-point modification with 4-20mA signal
I	Two pairs of Victaulic joints		

Water chillers and HP with Low GWP refrigerant WLE

WLE C WATER CHILLERS RATED TECHNICAL DATA

WLE			052	062	072	082	092	122	132	
Power supply		V-ph-Hz	400/3N/50							
Cooling capacity	(1)(E)	kW	45,3	57,9	66,3	76,8	85,7	116	131	
Total power input	(1)(E)	kW	10,5	13,5	15,2	17,7	19,8	26,3	29,9	
EER	(1)(E)		4,30	4,27	4,36	4,35	4,32	4,39	4,37	
SEER	(2)(E)		5,72	5,98	6,02	5,78	5,95	5,81	5,80	
Water flow user side	(1)	l/h	7796	9977	11418	13231	14763	19893	22476	
Water pressure drop user side	(1)(E)	kPa	31	49	45	45	43	45	35	
Water flow source side	(1)	l/h	9518	12143	13864	16074	17969	24151	27369	
Water pressure drop source side	(1)(E)	kPa	48	75	68	67	65	66	53	
Maximum current absorption		A	29,0	36,0	42,0	49,0	57,0	72,0	81,0	
Start up current		A	112	161	211	218	178	288	296	
Startup current with soft starter		A	67	97	127	131	107	173	178	
Compressors / circuits			2/1							
Sound power level	(3)	dB(A)	73	75	76	77	80	80	82	
Sound power level quiet version	(3)	dB(A)	61	63	64	65	68	68	70	
Sound power level, low-noise version	(3)	dB(A)	67	69	70	71	74	74	76	
Weight without options		kg	310	328	343	361	408	560	619	

WLE			152	154	182	184	212	214	242	
Power supply		V-ph-Hz	400/3N/50							
Cooling capacity	(1)(E)	kW	161	144	177	177	208	203	235	
Total power input	(1)(E)	kW	37,2	33,2	39,5	40,6	46,7	46,5	51,8	
EER	(1)(E)		4,33	4,34	4,47	4,36	4,46	4,38	4,54	
SEER	(2)(E)		6,06	5,54	6,09	6,48	5,84	6,11	5,78	
Water flow user side	(1)	l/h	27732	24792	30369	30429	35841	34985	40465	
Water pressure drop user side	(1)(E)	kPa	51	24	29	35	39	38	49	
Water flow source side	(1)	l/h	33758	30291	36888	37093	43502	42614	48918	
Water pressure drop source side	(1)(E)	kPa	78	37	44	53	60	57	74	
Maximum current absorption		A	91,0	90,0	112	114	130	128	151	
Start up current		A	356	224	380	293	399	307	420	
Startup current with soft starter		A	214	153	228	199	239	210	252	
Compressors / circuits			2/1	4/2	2/1	4/2	2/1	4/2	2/1	
Sound power level	(3)	dB(A)	87	79	87	83	89	83	89	
Sound power level quiet version	(3)	dB(A)	75	67	77	71	78	71	79	
Sound power level, low-noise version	(3)	dB(A)	81	73	83	77	84	77	85	
Weight without options		kg	688	997	727	932	799	973	869	

(1) Water temperature - user side 12°C / 7°C, water temperature - dissipation side 30°C / 35°C (EN14511:2022)

(2) η efficiency values for heating and cooling are respectively calculated by the following formulas: [$\eta = SCOP / 2,5 - F(1) - F(2)$] e [$\eta = SEER / 2,5 - F(1) - F(2)$]. For further information, please refer to the technical document "ErP 2009/125/EC DIRECTIVE" in the catalogue introducing pages, or to the EN14825:2022 regulation.

(3) Sound power level measured according to ISO 9614

(E) EUROVENT certified data

WLE C WATER CHILLERS RATED TECHNICAL DATA

WLE			244	274	314	364	384	454	504
Power supply		V-ph-Hz	400/3N/50						
Cooling capacity	(1)(E)	kW	231	262	296	349	376	419	478
Total power input	(1)(E)	kW	51,9	58,8	66,6	76,6	81,9	89,3	99,2
EER	(1)(E)		4,45	4,46	4,44	4,56	4,59	4,69	4,81
SEER	(2)(E)		6,14	6,08	6,40	6,38	6,11	6,71	6,77
Water flow user side	(1)	l/h	39728	45112	50884	59992	64563	72043	82068
Water pressure drop user side	(1)(E)	kPa	42	43	41	44	44	25	31
Water flow source side	(1)	l/h	48233	54764	61834	72580	78025	86936	98537
Water pressure drop source side	(1)(E)	kPa	61	64	63	66	66	43	53
Maximum current absorption		A	144	161	182	224	240	261	303
Start up current		A	360	377	447	492	508	529	571
Startup current with soft starter		A	244	259	305	340	353	369	403
Compressors / circuits			4/2						
Sound power level	(3)	dB(A)	83	85	90	90	90	92	92
Sound power level quiet version	(3)	dB(A)	71	73	78	80	80	81	82
Sound power level, low-noise version	(3)	dB(A)	77	79	84	86	86	87	88
Weight without options		kg	992	1101	1393	1491	1523	1925	1968

WLE			606	636	696	746
Power supply		V-ph-Hz	400/3N/50			
Cooling capacity	(1)(E)	kW	557	612	664	720
Total power input	(1)(E)	kW	120	134	144	151
EER	(1)(E)		4,66	4,56	4,60	4,76
SEER	(2)(E)		6,69	6,73	6,72	6,80
Water flow user side	(1)	l/h	95729	105158	114046	123665
Water pressure drop user side	(1)(E)	kPa	38	43	52	60
Water flow source side	(1)	l/h	115496	127315	137734	148470
Water pressure drop source side	(1)(E)	kPa	63	62	71	70
Maximum current absorption		A	328	370	412	454
Start up current		A	593	638	680	722
Startup current with soft starter		A	421	457	491	524
Compressors / circuits			6/2			
Sound power level	(3)	dB(A)	94	94	94	94
Sound power level quiet version	(3)	dB(A)	82	83	83	84
Sound power level, low-noise version	(3)	dB(A)	88	89	89	90
Weight without options		kg	2592	2689	2648	2752

(1) Water temperature - user side 12°C / 7°C, water temperature - dissipation side 30°C / 35°C (EN14511:2022)

(2) η efficiency values for heating and cooling are respectively calculated by the following formulas: $[\eta = SCOP / 2,5 - F(1) - F(2)]$ e $[\eta = SEER / 2,5 - F(1) - F(2)]$. For further information, please refer to the technical document "ErP 2009/125/EC DIRECTIVE" in the catalogue introducing pages, or to the EN14825:2022 regulation.

(3) Sound power level measured according to ISO 9614

(E) EUROVENT certified data

Water chillers and HP with Low GWP refrigerant WLE

WLE H NOT REVERSIBLE HEAT PUMPS TECHNICAL DATA

WLE			052	062	072	082	092	122	132	
Power supply		V-ph-Hz	400/3N/50							
Cooling capacity	(1)(E)	kW	44,9	55,6	65,4	76,4	85,7	114	130	
Total power input	(1)(E)	kW	11,6	13,9	16,1	18,9	20,6	28,3	32,0	
EER	(1)(E)		3,87	4,00	4,06	4,04	4,16	4,04	4,07	
SEER	(2)(E)		5,64	5,89	5,93	5,69	5,86	5,72	5,71	
Water flow user side	(1)	l/h	7733	9570	11263	13152	14752	19655	22430	
Water pressure drop user side	(1)(E)	kPa	31	45	44	44	43	44	35	
Water flow source side	(1)	l/h	9628	11798	13857	16198	18082	24237	27671	
Water pressure drop source side	(1)(E)	kPa	49	71	68	68	66	67	54	
Heating capacity	(3)(E)	kW	49,0	64,3	75,3	87,9	96,6	130	148	
Total power input	(3)(E)	kW	13,2	17,0	19,5	21,8	24,1	33,0	37,5	
COP	(3)(E)		3,71	3,78	3,86	4,03	4,01	3,94	3,95	
Heating energy efficiency class	(4)		A+++							
SCOP	(2)(E)		5,41	5,49	5,52	5,45	5,23	5,48	5,52	
Water flow user side	(3)	l/h	9048	11481	13451	15697	17258	23403	26532	
Water pressure drop user side	(3)(E)	kPa	44	68	64	65	60	63	50	
Water flow source side	(3)	l/h	11247	14471	17045	20155	22073	29829	33678	
Water pressure drop source side	(3)(E)	kPa	61	95	93	96	88	93	72	
Maximum current absorption		A	29,0	36,0	42,0	49,0	57,0	72,0	81,0	
Start up current		A	112	161	211	218	178	288	296	
Startup current with soft starter		A	67	97	127	131	107	173	178	
Compressors / circuits			2/1							
Sound power level	(5)	dB(A)	73	75	76	77	80	80	82	
Sound power level, low-noise version	(5)	dB(A)	67	69	70	71	74	74	76	
Sound power level quiet version	(5)	dB(A)	61	63	64	65	68	68	70	
Weight without options		kg	315	334	353	371	418	572	635	

WLE			152	154	182	184	212	214	242	
Power supply		V-ph-Hz	400/3N/50							
Cooling capacity	(1)(E)	kW	149	145	174	177	204	203	230	
Total power input	(1)(E)	kW	37,0	36,3	42,4	43,7	49,1	51,2	54,4	
EER	(1)(E)		4,02	4,00	4,11	4,05	4,16	3,96	4,23	
SEER	(2)(E)		5,97	5,46	6,00	6,38	5,75	6,02	5,69	
Water flow user side	(1)	l/h	25587	24972	29949	30431	35122	34845	39546	
Water pressure drop user side	(1)(E)	kPa	44	25	28	35	38	37	47	
Water flow source side	(1)	l/h	31604	30973	36938	37608	43180	43251	48433	
Water pressure drop source side	(1)(E)	kPa	69	39	44	55	59	59	72	
Heating capacity	(3)(E)	kW	167	163	196	200	237	230	261	
Total power input	(3)(E)	kW	42,6	41,3	48,6	50,0	57,5	57,2	63,2	
COP	(3)(E)		3,92	3,95	4,03	4,00	4,12	4,02	4,13	
Heating energy efficiency class	(4)		A+++							
SCOP	(2)(E)		5,59	5,28	5,61	5,79	5,68	5,88	5,47	
Water flow user side	(3)	l/h	30026	29241	35166	35854	42453	41240	46757	
Water pressure drop user side	(3)(E)	kPa	63	35	41	50	57	54	68	
Water flow source side	(3)	l/h	38117	36958	44800	45642	54595	52583	60304	
Water pressure drop source side	(3)(E)	kPa	90	50	58	73	83	78	100	
Maximum current absorption		A	91,0	90,0	112	114	130	128	151	
Start up current		A	356	224	380	293	399	307	420	
Startup current with soft starter		A	214	153	228	199	239	210	252	
Compressors / circuits			2/1	4/2	2/1	4/2	2/1	4/2	2/1	
Sound power level	(5)	dB(A)	87	79	87	83	89	83	89	
Sound power level, low-noise version	(5)	dB(A)	81	73	83	77	84	77	85	
Sound power level quiet version	(5)	dB(A)	75	67	77	71	78	71	79	
Weight without options		kg	706	1014	746	948	820	991	893	

(1) Water temperature - user side 12°C / 7°C, water temperature - dissipation side 30°C / 35°C (EN14511:2022)

(2) η efficiency values for heating and cooling are respectively calculated by the following formulas: $[\eta = SCOP / 2,5 - F(1) - F(2)] e [\eta = SEER / 2,5 - F(1) - F(2)]$. For further information, please refer to the technical document "ErP 2009/125/EC DIRECTIVE" in the catalogue introducing pages, or to the EN14825:2022 regulation.

(3) Water temperature - user side 40°C / 45°C, water temperature - source side 10°C / 7°C (EN14511:2022)

(4) Seasonal energy efficiency class for LOW TEMPERATURE room heating under AVERAGE climatic conditions [EUROPEAN REGULATION No 811/2013. The energy efficiency class of this product is included in the range A+++ → D]

(5) Sound power level measured according to ISO 9614

(E) EUROVENT certified data

WLE H NOT REVERSIBLE HEAT PUMPS TECHNICAL DATA

WLE			244	274	314	364	384	454	504
Power supply		V-ph-Hz	400/3N/50						
Cooling capacity	(1)(E)	kW	229	261	296	349	376	420	474
Total power input	(1)(E)	kW	57,3	64,7	73,9	85,1	91,0	96,2	106
EER	(1)(E)		4,00	4,03	4,01	4,11	4,14	4,37	4,46
SEER	(2)(E)		6,05	5,99	6,31	6,29	6,02	6,61	6,67
Water flow user side	(1)	l/h	39448	44776	50946	60069	64702	72203	81499
Water pressure drop user side	(1)(E)	kPa	41	42	41	44	44	25	31
Water flow source side	(1)	l/h	48841	55392	63082	74035	79646	88222	99146
Water pressure drop source side	(1)(E)	kPa	63	65	66	68	68	44	54
Heating capacity	(3)(E)	kW	257	297	338	392	423	468	524
Total power input	(3)(E)	kW	64,1	73,5	82,8	95,9	103	112	124
COP	(3)(E)		4,01	4,04	4,08	4,09	4,11	4,18	4,23
Heating energy efficiency class	(4)		A+++						
SCOP	(2)(E)		5,85	5,82	5,91	5,85	5,74	6,11	6,06
Water flow user side	(3)	l/h	46051	53227	60587	70288	75962	83958	93908
Water pressure drop user side	(3)(E)	kPa	56	61	61	62	63	41	49
Water flow source side	(3)	l/h	58716	68084	77680	90152	97599	107671	121103
Water pressure drop source side	(3)(E)	kPa	84	90	88	91	93	52	63
Maximum current absorption		A	144	161	182	224	240	261	303
Start up current		A	360	377	447	492	508	529	571
Startup current with soft starter		A	244	259	305	340	353	369	403
Compressors / circuits			4/2						
Sound power level	(5)	dB(A)	83	85	90	90	90	92	92
Sound power level, low-noise version	(5)	dB(A)	77	79	84	86	86	87	88
Sound power level quiet version	(5)	dB(A)	71	73	78	80	80	81	82
Weight without options		kg	1012	1121	1425	1523	1555	1959	2008

(1) Water temperature - user side 12°C / 7°C, water temperature - dissipation side 30°C / 35°C (EN14511:2022)

(2) η efficiency values for heating and cooling are respectively calculated by the following formulas: $[\eta = SCOP / 2,5 - F(1) - F(2)]$ e $[\eta = SEER / 2,5 - F(1) - F(2)]$. For further information, please refer to the technical document "ErP 2009/125/EC DIRECTIVE" in the catalogue introducing pages, or to the EN14825:2022 regulation.

(3) Water temperature - user side 40°C / 45°C, water temperature - source side 10°C / 7°C (EN14511:2022)

(4) Seasonal energy efficiency class for LOW TEMPERATURE room heating under AVERAGE climatic conditions [EUROPEAN REGULATION No 811/2013. The energy efficiency class of this product is included in the range A+++ → D]

(5) Sound power level measured according to ISO 9614

(E) EUROVENT certified data

Water chillers and HP with Low GWP refrigerant WLE

WLE H NOT REVERSIBLE HEAT PUMPS TECHNICAL DATA

WLE			606	636	696	746
Power supply		V-ph-Hz	400/3N/50			
Cooling capacity	(1)(E)	kW	543	597	650	700
Total power input	(1)(E)	kW	129	141	151	167
EER	(1)(E)		4,20	4,24	4,29	4,19
SEER	(2)(E)		6,59	6,63	6,62	6,70
Water flow user side	(1)	l/h	93295	102590	111672	120233
Water pressure drop user side	(1)(E)	kPa	36	41	50	57
Water flow source side	(1)	l/h	114637	125788	136556	147523
Water pressure drop source side	(1)(E)	kPa	62	68	70	80
Heating capacity	(3)(E)	kW	612	673	741	799
Total power input	(3)(E)	kW	150	164	180	192
COP	(3)(E)		4,08	4,10	4,12	4,16
Heating energy efficiency class	(4)		A+++			
SCOP	(2)(E)		6,15	6,03	6,01	6,19
Water flow user side	(3)	l/h	109766	120603	132795	143252
Water pressure drop user side	(3)(E)	kPa	57	63	67	76
Water flow source side	(3)	l/h	140216	154510	170722	185132
Water pressure drop source side	(3)(E)	kPa	76	86	107	124
Maximum current absorption		A	328	370	412	454
Start up current		A	593	638	680	722
Startup current with soft starter		A	421	457	491	524
Compressors / circuits			6/2			
Sound power level	(5)	dB(A)	94	94	94	94
Sound power level, low-noise version	(5)	dB(A)	88	89	89	90
Sound power level quiet version	(5)	dB(A)	82	83	83	84
Weight without options		kg	2669	2775	2734	2838

(1) Water temperature - user side 12°C / 7°C, water temperature - dissipation side 30°C / 35°C (EN14511:2022)

(2) η efficiency values for heating and cooling are respectively calculated by the following formulas: $[\eta = SCOP / 2,5 - F(1) - F(2)]$ e $[\eta = SEER / 2,5 - F(1) - F(2)]$. For further information, please refer to the technical document "ErP 2009/125/EC DIRECTIVE" in the catalogue introducing pages, or to the EN14825:2022 regulation.

(3) Water temperature - user side 40°C / 45°C, water temperature - source side 10°C / 7°C (EN14511:2022)

(4) Seasonal energy efficiency class for LOW TEMPERATURE room heating under AVERAGE climatic conditions [EUROPEAN REGULATION No 811/2013]. The energy efficiency class of this product is included in the range A+++ → D]

(5) Sound power level measured according to ISO 9614

(E) EUROVENT certified data

DIMENSIONAL DRAWINGS

WLE 52 - 92

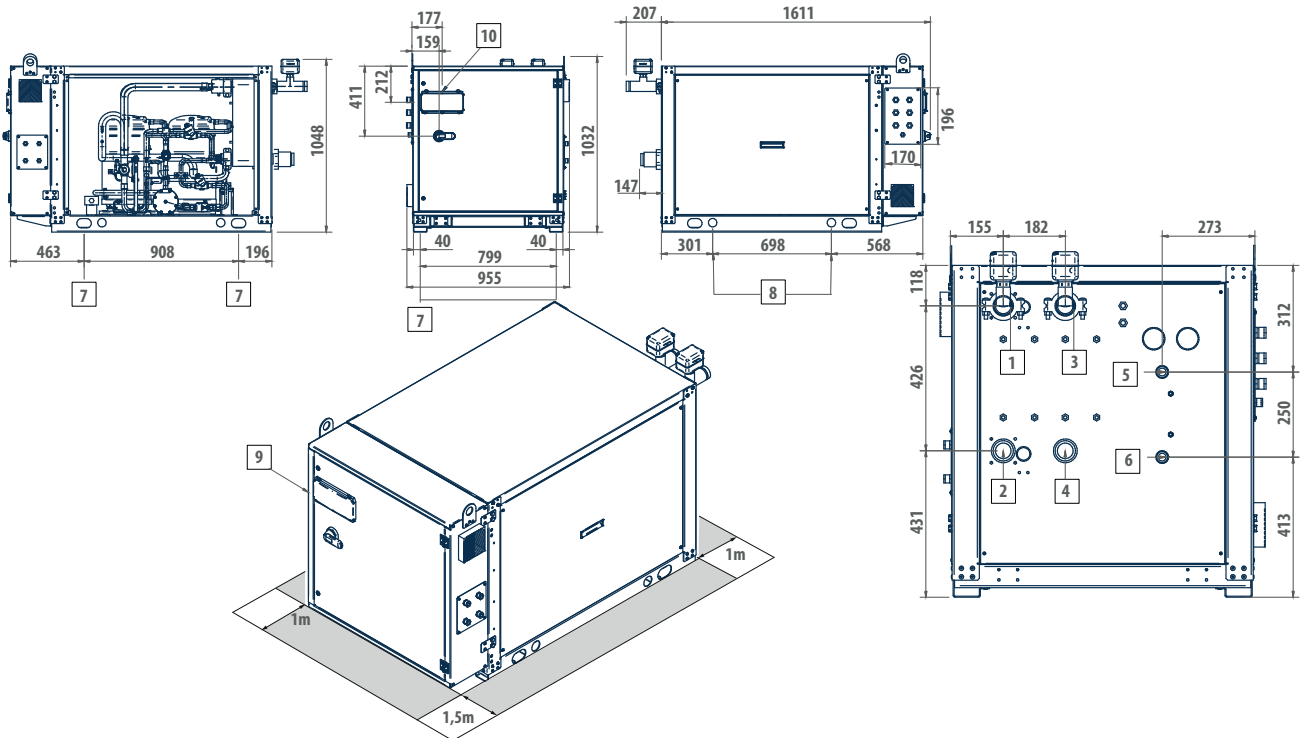

LEGEND WLE C

1	Dissipation side - outlet (Victaulic 2")
2	Dissipation side - inlet Victaulic (Victaulic 2")
3	User side - inlet (Victaulic 2")
4	User side - outlet (Victaulic 2")
5	De-superheater water outlet 1"
6	Desuperheater water inlet 1"
7	Vibration dumpers
8	Lifting points
9	Power supply input
10	User interface

CHILLER FLOW SWITH POSITION: 2-3

CLOSING PANELLING AVAILABLE ON REQUEST

LEGEND WLE H

1	Dissipation side - inlet Victaulic (Victaulic 2")
2	Dissipation side - outlet (Victaulic 2")
3	User side - inlet (Victaulic 2")
4	User side - outlet (Victaulic 2")
5	De-superheater water outlet 1"
6	Desuperheater water inlet 1"
7	Vibration dumpers
8	Lifting points
9	Power supply input
10	User interface

HEAT PUMP FLOW SWITH POSITION: 1-3

CLOSING PANELLING AVAILABLE ON REQUEST

Water chillers and HP with Low GWP refrigerant WLE

DIMENSIONAL DRAWINGS

WLE 122 - 152

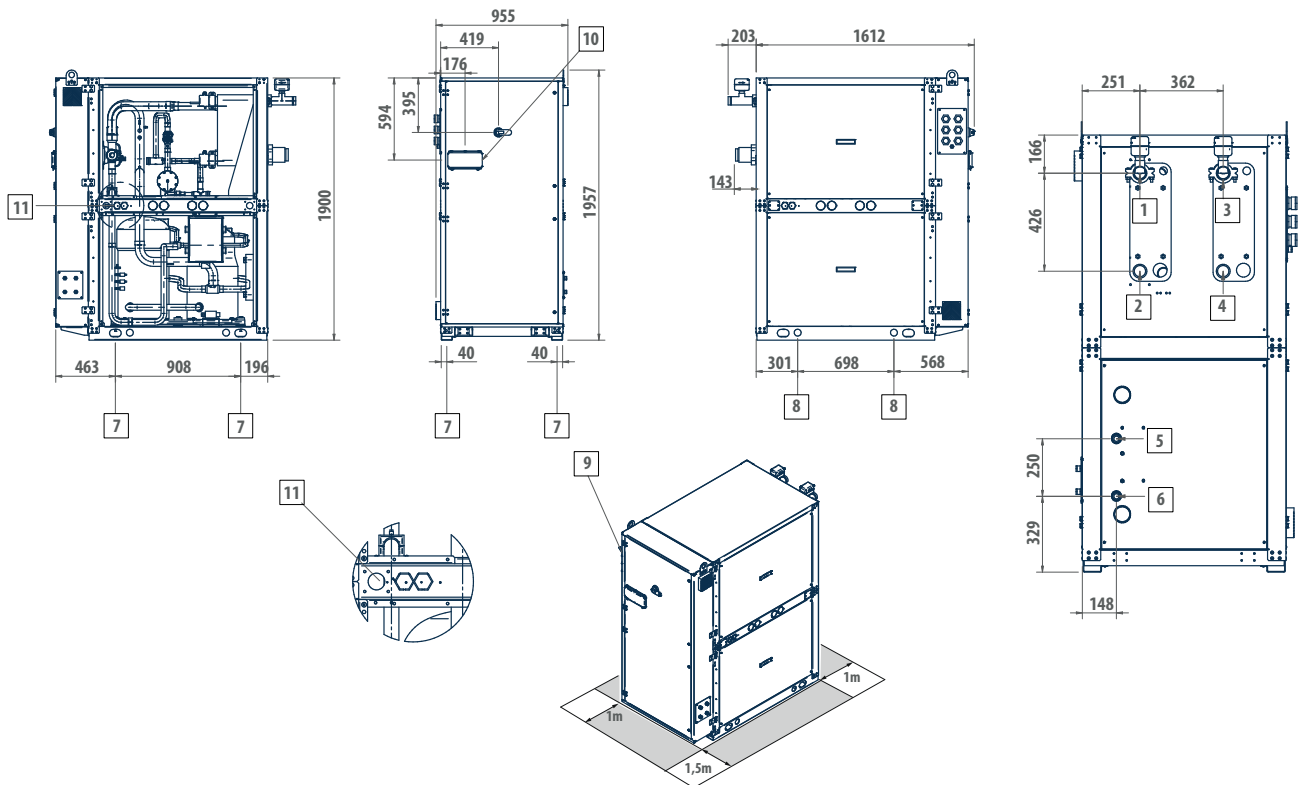

LEGEND WLE C

1	Dissipation side - outlet (Victaulic 2")
2	Dissipation side - inlet Victaulic (Victaulic 2")
3	User side - inlet (Victaulic 2")
4	User side - outlet (Victaulic 2")
5	De-superheater water outlet 1"
6	Desuperheater water inlet 1"
7	Vibration dumpers
8	Lifting points
9	Power supply input
10	User interface
11	Outlet safety valve G. 3/4" F (only 152)

CHILLER FLOW SWITH POSITION: 2-3

CLOSING PANELLING AVAILABLE ON REQUEST

LEGEND WLE H

1	Dissipation side - inlet Victaulic (Victaulic 2")
2	Dissipation side - outlet (Victaulic 2")
3	User side - inlet (Victaulic 2")
4	User side - outlet (Victaulic 2")
5	De-superheater water outlet 1"
6	Desuperheater water inlet 1"
7	Vibration dumpers
8	Lifting points
9	Power supply input
10	User interface
11	Outlet safety valve G. 3/4" F (only 152)

HEAT PUMP FLOW SWITH POSITION: 1-3

CLOSING PANELLING AVAILABLE ON REQUEST

DIMENSIONAL DRAWINGS

WLE 182-242

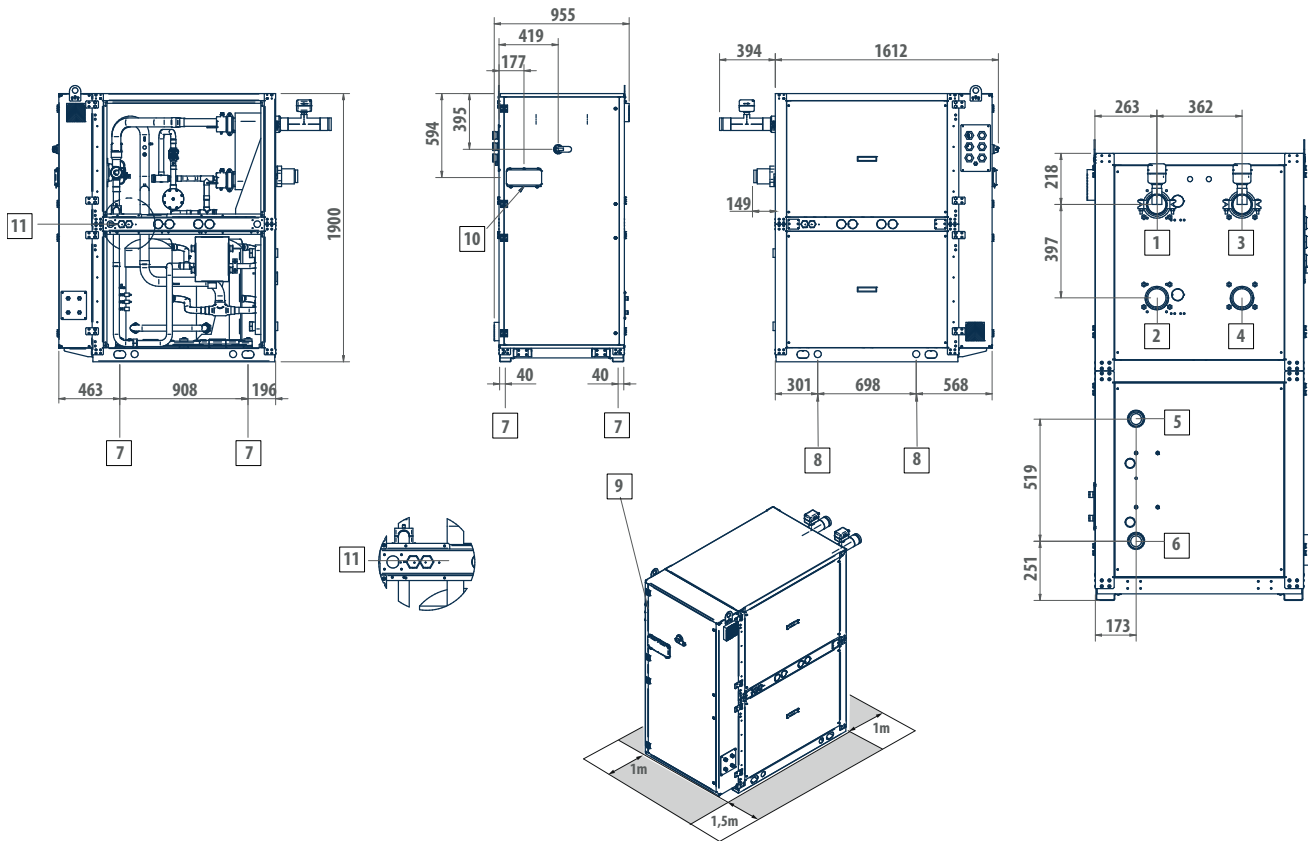

LEGEND WLE C

1	Dissipation side - outlet (Victaulic 3")
2	Dissipation side - inlet (Victaulic 3")
3	User side - inlet (Victaulic 3")
4	User side - outlet (Victaulic 3")
5	De-superheater water outlet 2"
6	Desuperheater water inlet 2"
7	Vibration dumpers
8	Lifting points
9	Power supply input
10	User interface
11	Outlet safety valve G. 3/4" F

CHILLER FLOW SWITH POSITION: 2-3

CLOSING PANNELLING AVAILABLE ON REQUEST

LEGEND WLE H

1	Dissipation side - inlet (Victaulic 3")
2	Dissipation side - outlet (Victaulic 3")
3	User side - inlet (Victaulic 3")
4	User side - outlet (Victaulic 3")
5	De-superheater water outlet 2"
6	Desuperheater water inlet 2"
7	Vibration dumpers
8	Lifting points
9	Power supply input
10	User interface
11	Outlet safety valve G. 3/4" F

HEAT PUMP FLOW SWITH POSITION: 1-3

CLOSING PANNELLING AVAILABLE ON REQUEST

Water chillers and HP with Low GWP refrigerant WLE

DIMENSIONAL DRAWINGS

WLE 154-274

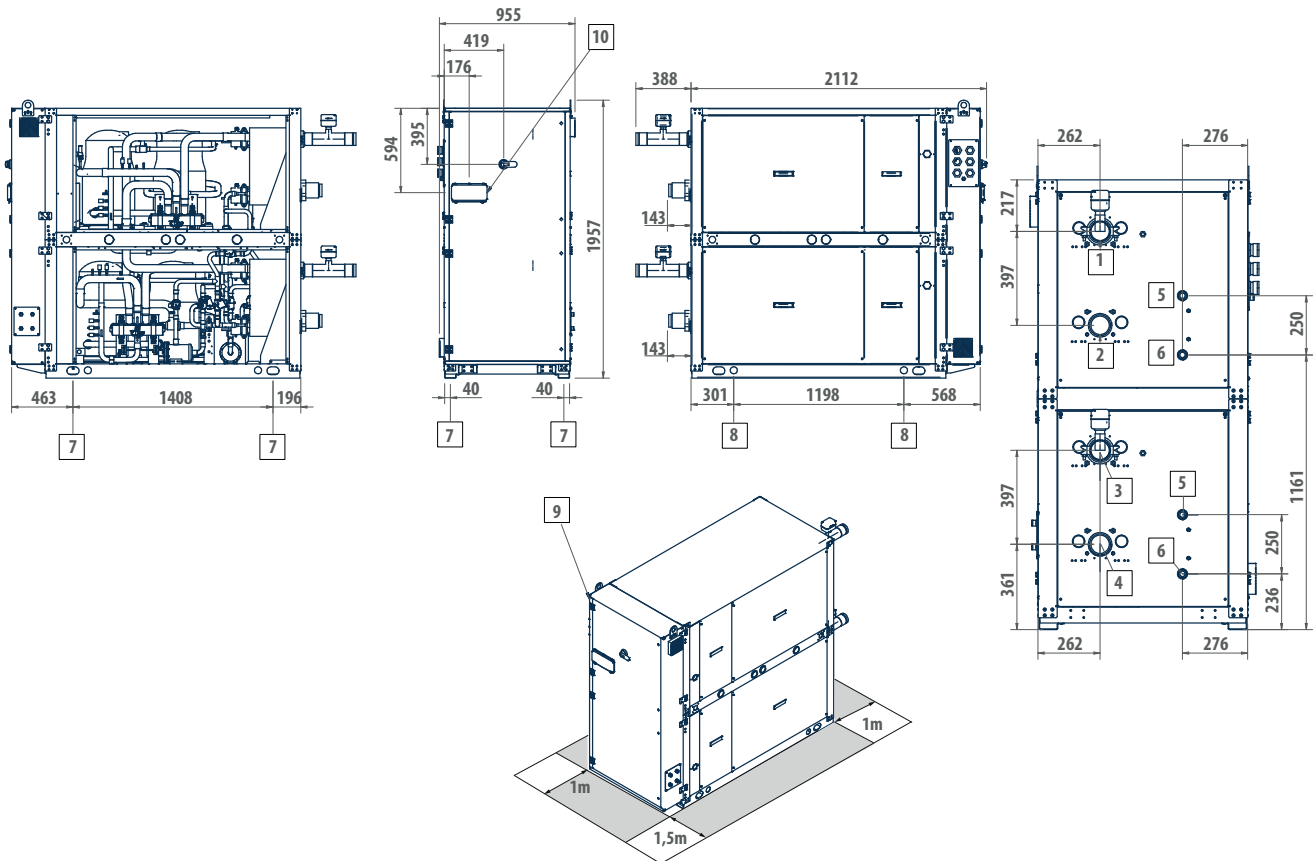

LEGEND WLE C

- | | |
|----|--|
| 1 | User side - inlet (Victaulic 3") |
| 2 | User side - outlet (Victaulic 3") |
| 3 | Dissipation side - outlet (Victaulic 3") |
| 4 | Dissipation side - inlet (Victaulic 3") |
| 5 | De-superheater water outlet 2" |
| 6 | Desuperheater water inlet 2" |
| 7 | Vibration dumpers |
| 8 | Lifting points |
| 9 | Power supply input |
| 10 | User interface |

CHILLER FLOW SWITH POSITION: 1-4

CLOSING PANELLING AVAILABLE ON REQUEST

LEGEND WLE H

- | | |
|----|--|
| 1 | User side - inlet (Victaulic 3") |
| 2 | User side - outlet (Victaulic 3") |
| 3 | Dissipation side - inlet (Victaulic 3") |
| 4 | Dissipation side - outlet (Victaulic 3") |
| 5 | De-superheater water outlet 2" |
| 6 | Desuperheater water inlet 2" |
| 7 | Vibration dumpers |
| 8 | Lifting points |
| 9 | Power supply input |
| 10 | User interface |

HEAT PUMP FLOW SWITH POSITION: 1-3

CLOSING PANELLING AVAILABLE ON REQUEST

DIMENSIONAL DRAWINGS

WLE 314 - 384

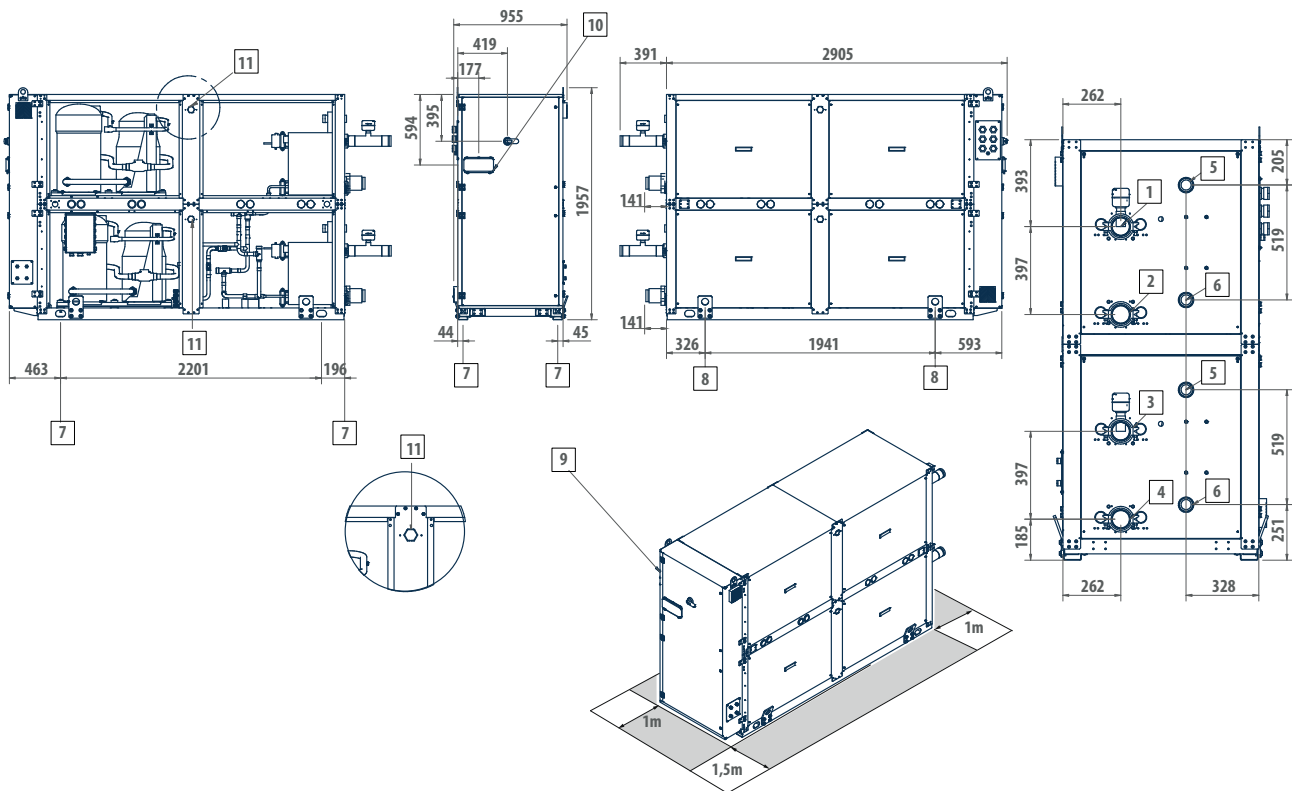

LEGEND WLE C

1	User side - inlet (Victaulic 3")
2	User side - outlet (Victaulic 3")
3	Dissipation side - outlet (Victaulic 3")
4	Dissipation side - inlet (Victaulic 3")
5	De-superheater water outlet 2"
6	Desuperheater water inlet 2"
7	Vibration dumpers
8	Lifting points
9	Power supply input
10	User interface
11	Outlet safety valve G. 1" F

CHILLER FLOW SWITH POSITION: 1-4

CLOSING PANELLING AVAILABLE ON REQUEST

LEGEND WLE H

1	User side - inlet (Victaulic 3")
2	User side - outlet (Victaulic 3")
3	Dissipation side - inlet (Victaulic 3")
4	Dissipation side - outlet (Victaulic 3")
5	De-superheater water outlet 2"
6	Desuperheater water inlet 2"
7	Vibration dumpers
8	Lifting points
9	Power supply input
10	User interface
11	Outlet safety valve G. 1" F

HEAT PUMP FLOW SWITH POSITION: 1-3

CLOSING PANELLING AVAILABLE ON REQUEST

Water chillers and HP with Low GWP refrigerant WLE

DIMENSIONAL DRAWINGS

WLE 454 - 504

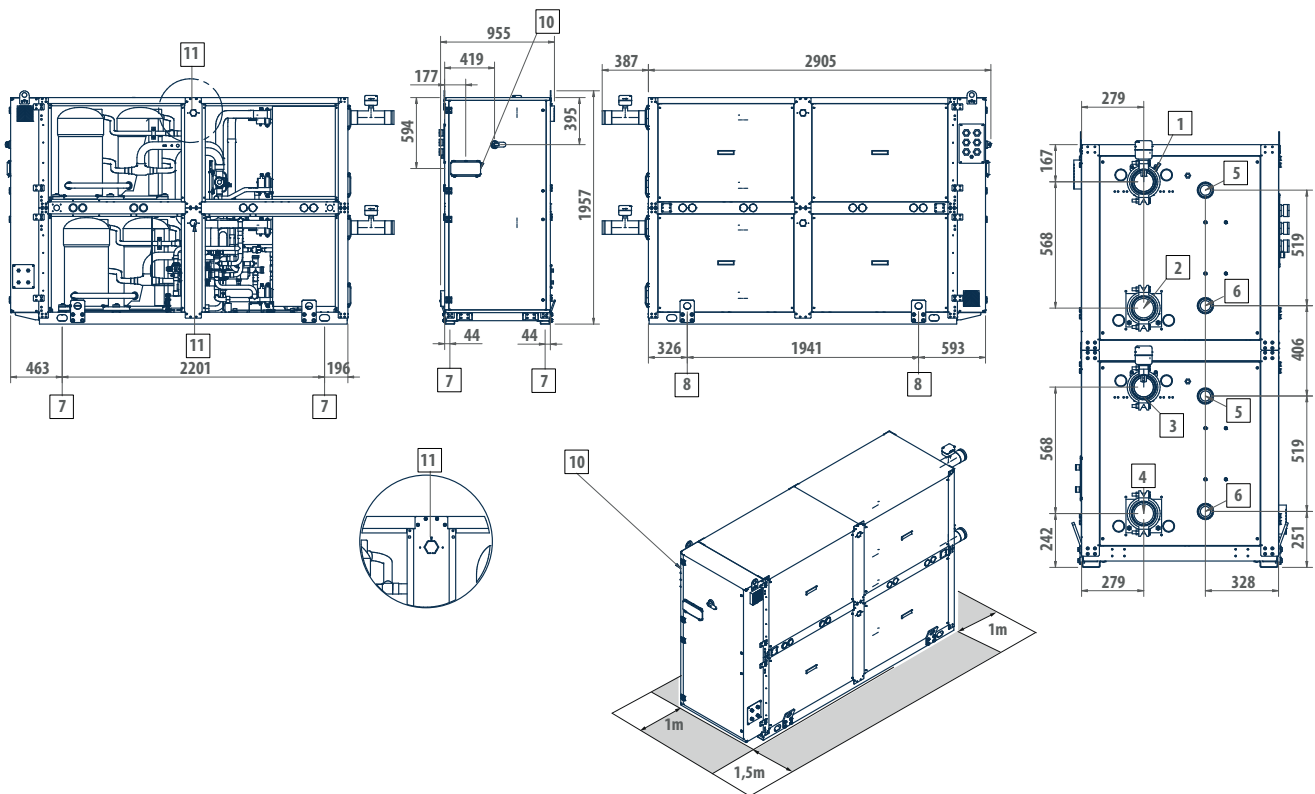

LEGEND WLE C

1	User side - inlet (Victaulic 4")
2	User side - outlet (Victaulic 4")
3	Dissipation side - outlet (Victaulic 4")
4	Dissipation side - inlet (Victaulic 4")
5	De-superheater water outlet 2"
6	Desuperheater water inlet 2"
7	Vibration dumpers
8	Lifting points
9	Power supply input
10	User interface
11	Outlet safety valve G. 1" F

CHILLER FLOW SWITH POSITION: 1-4

CLOSING PANELLING AVAILABLE ON REQUEST

LEGEND WLE H

1	User side - inlet (Victaulic 4")
2	User side - outlet (Victaulic 4")
3	Dissipation side - inlet (Victaulic 4")
4	Dissipation side - outlet (Victaulic 4")
5	De-superheater water outlet 2"
6	Desuperheater water inlet 2"
7	Vibration dumpers
8	Lifting points
9	Power supply input
10	User interface
11	Outlet safety valve G. 1" F

HEAT PUMP FLOW SWITH POSITION: 1-3

CLOSING PANELLING AVAILABLE ON REQUEST

DIMENSIONAL DRAWINGS

WLE 606 - 746

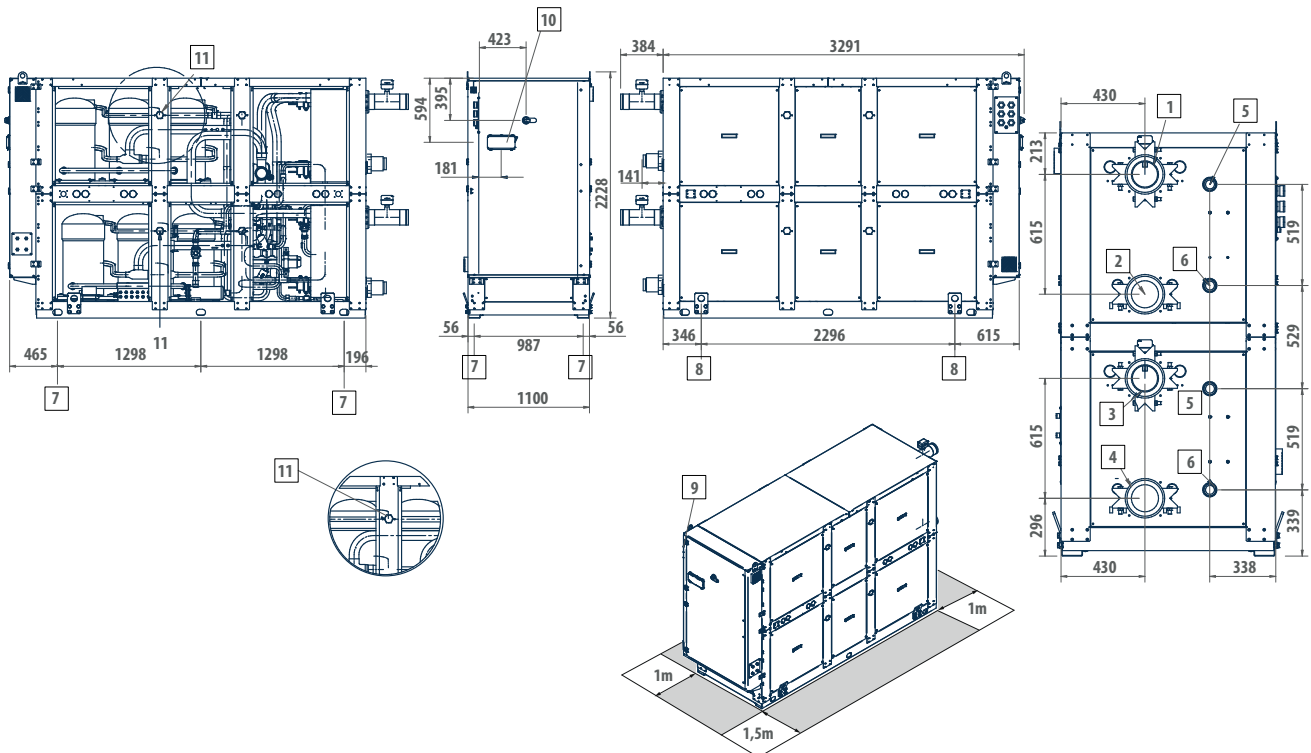

LEGEND WLE C

1	User side - inlet (Victaulic 5")
2	User side - outlet (Victaulic 5")
3	Dissipation side - outlet (Victaulic 5")
4	Dissipation side - inlet (Victaulic 5")
5	De-superheater water outlet 2"
6	Desuperheater water inlet 2"
7	Vibration dumpers
8	Lifting points
9	Power supply input
10	User interface
11	Outlet safety valve G. 1" 1/4 F

CHILLER FLOW SWITH POSITION: 1-4

CLOSING PANNELLING AVAILABLE ON REQUEST

LEGEND WLE H

1	User side - inlet (Victaulic 5")
2	User side - outlet (Victaulic 5")
3	Dissipation side - inlet (Victaulic 5")
4	Dissipation side - outlet (Victaulic 5")
5	De-superheater water outlet 2"
6	Desuperheater water inlet 2"
7	Vibration dumpers
8	Lifting points
9	Power supply input
10	User interface
11	Outlet safety valve G. 1" 1/4 F

HEAT PUMP FLOW SWITH POSITION: 1-3

CLOSING PANNELLING AVAILABLE ON REQUEST



MF - MULTI-PURPOSE

Introduction	p.346
MLE	p.350
PLN P	p.362
LEP	p.370



Total heat recovery multi-purpose units

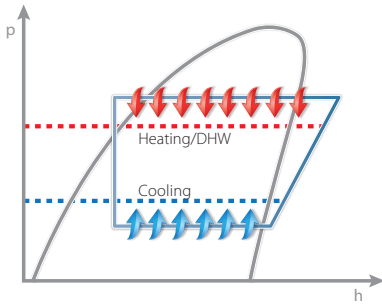

Energy saving thanks to a total recovery

Galletti multi-purpose heat pumps are total recovery units used for a simultaneous hot and cold water production. Available for a 2-pipe system, DHW production under request, or a 4-pipe system, designed for service and residential sectors. As well as winter heating and summer air conditioning, in case of a 2-pipe air-conditioning systems in which, thermal power for the DHW production is required, Galletti multi-purpose systems are equipped with a plate heat exchanger used for the DHW production. Thanks to the advanced technology of these systems, they can satisfy this request in every season, also when there is no need of air-conditioning, but that's not all! They can do that efficiently by using the total recovery of condensation heat available during cooling phase.

Production of chilled water with total condensation heat recovery for DHW production

- S1: "user side" plate exchanger
- S2: "DHW production side" plate exchanger
- S3: Finned block heat exchanger

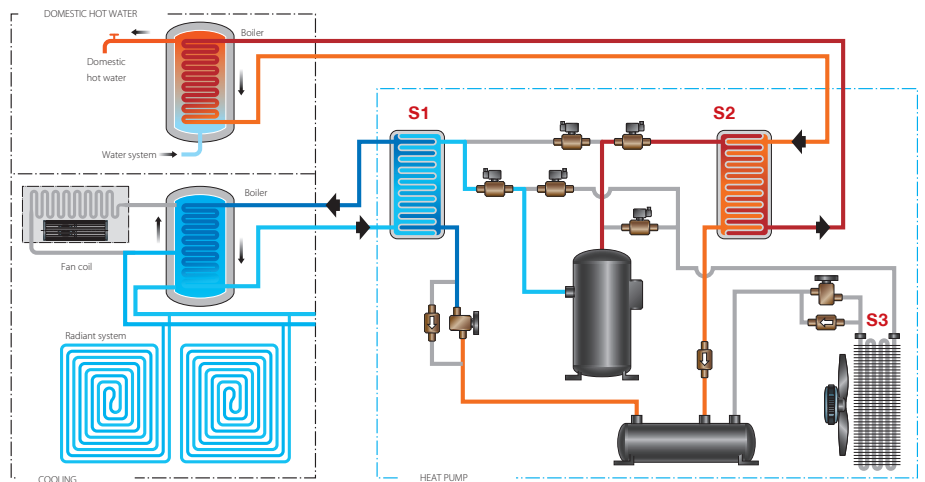



Partial load efficiency

It is necessary to guarantee that the generation system provides high values of COP/EER even in partial load efficiency which, often, corresponds to the greatest number of working hours in a seasonal cycle.

According to Galletti multi-purpose series, this purpose is achieved through a meticulous thermodynamic design of all main components.

As for the multi-purpose heat pumps which have one cooling circuit, it is possible to modulate the thermal power released through the variation of frequency in the single compressor activated by a BLDC motor.

When on-off compressors are used, high efficiency is guaranteed also for partial loads through different steps of operation due to compressors, divided in one or two thermodynamic circuits.

Additional total recovery heat pumps compared to traditional generation systems.

- » High renewable energy availability can be obtained from the environment using different methods
- » Respect for the environment through energy efficiency due to the excellent COP and EER values
- » Reduction in the consumption of fossil energy (ideal for photovoltaic systems combinations)
- » Risks of explosion, fire and indoor burning materials poisoning prevented
- » Totally programmable with the possibility of remote management and on line assistance
- » Low maintenance due to the absence of wearing parts
- » Low-noise execution
- » No CO₂ and local harmful emissions
- » It does not pollute and it can be fueled by renewable energy sources
- » Maximum savings on running costs combined with high environmental sustainability
- » One unit substituting boilers and air-conditioning units



Total heat recovery multi-purpose units

AVAILABLE VERSIONS

MULTI-PURPOSE M - 2-pipe systems

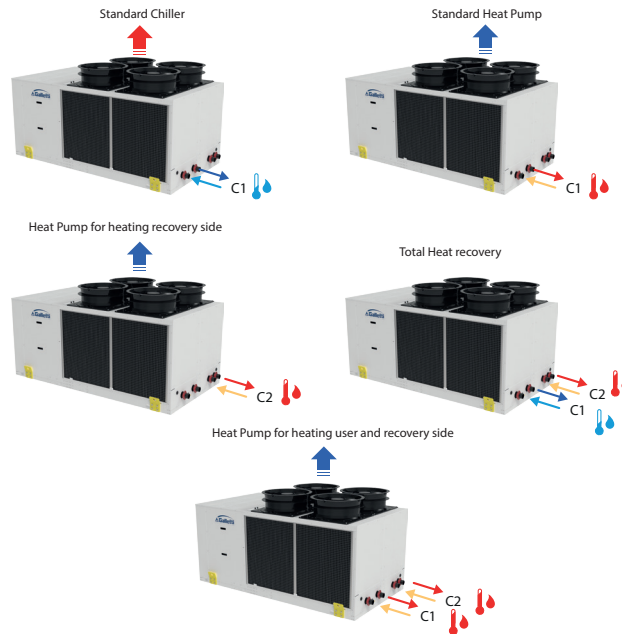

Operating modes available for the multi-purpose unit in M version, which interfaces with a 2-pipe system.

C1 Hydraulic circuit manages winter heating and summer air-conditioning while the C2 one is used for the production of DHW, ensuring this function 365 days per year.

In case of simultaneous production of cold (C1) and high-temperature water for domestic use (C2), the machine is able to recover all the condensation heat on the refrigerant for the production of DHW.

MULTI-PURPOSE P - 4-pipe systems

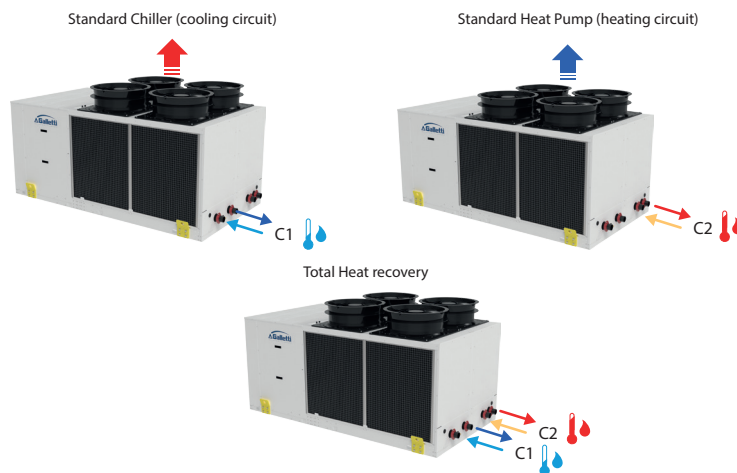

Operating modes available for the multi-purpose unit in P version, which interfaces with a 4-pipe air conditioning system.

In this kind of systems, it is possible to request air-conditioning and heating at the same time. For this reason, C1 and C2 hydraulic circuits respectively produce cold and hot water.

In case of simultaneous operation of C1 and C2 hydraulic circuits, the condensation heat of the cooling system is totally recovered for the production of hot water.

Available operating modes



Cooling

In the "Standard Chiller" mode, the multifunctional unit chills water to cool a room on the user side, dissipating the condensation heat in air by means of a finned block condenser.

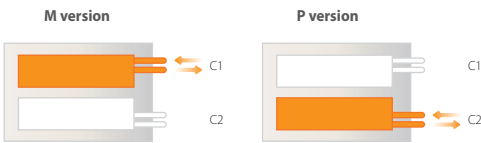

Heating

In the "Heat Pump" mode, the unit heats the water in the condenser to provide heating on the user side (C1 for M versions and C2 for P versions), absorbing the evaporative cooling capacity in air by means of a finned block heat exchanger.



Hot water production for sanitary use-DHW

In the "Heat Pump for hot production recovery side" mode the multipurpose unit in the M version heats the water in the recoverer, absorbing the evaporative cooling capacity in air by means of a finned block heat exchanger.



simultaneous

Cooling and hot water production through total recovery

In the "Total recovery" mode the multifunctional unit can produce chilled water with the simultaneous production of high-temperature hot water, thanks to total heat recovery.



simultaneous

Hot water production for sanitary use simultaneously with heating

The unit in M version, in "Heat Pump for hot production user and recovery side" mode heats water in parallel, optimally exploiting the complete independence of its thermodynamic circuits, allowing simultaneous water heating serving user site and for DHW. Capacity is equally divided between the two circuits.

The solution to the problem of defrosting

During the wintertime period, especially with temperatures ranging between -3°C and $+3^{\circ}\text{C}$, the high ambient relative humidity causes the formation of water condensation around the exchanger fins.

Since the exchanger is at a lower temperature than the outdoor air, the water in contact with it ends up hindering the heat exchange necessary for the system to work correctly.

A defrost cycle is a temporary reversal of the thermodynamic cycle which switches the unit into the summer mode and melts the ice present between fins.

This phase is obviously problematic, since the cooling cycle warms up the exchanger by drawing heat from the room that was previously being heated. The defrosting circuit will draw heat on the user side (that is, not on the DHW side) in version M, and will heat the hot water user side in version P.

Separate defrosting



The Galletti ranges reduce this problem with the following technical innovations:

- The two thermodynamic circuits are completely independent and while one defrosts, the other circuit is able to ensure continuity in the unit's operation, with practically no thermal discomfort for the user.
- The software which manages the defrost cycle minimizes the time it takes to complete it and only acts when it is really necessary. The fans are pushed to their maximum capacity at just the right time, that is, when the ice is no longer stuck to the fins, and mechanically ejects it from the heat exchanger.

Outdoor packaged air-water unit

MLE 40 - 240 kW

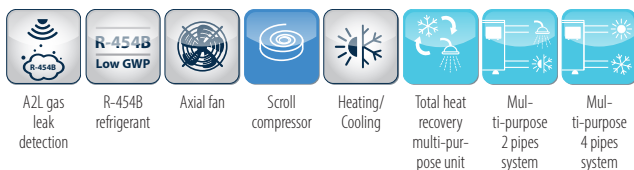

PLUS

- » Refrigerant with GWP of less than 500
- » Total heat recovery
- » High seasonal efficiency values
- » Electronic expansion valve
- » 2 cooling circuits
- » Possibility to configure low-noise versions
- » Production of hot water up to 55°C
- » Full load operation up to -15°C outside air temperature

Air-water unit with total recovery heat and high seasonal efficiency and low GWP refrigerant

MLE is the new range Galletti of air-cooled packaged multifunctional heat pumps with total heat recovery for outdoor installation featuring R454B refrigerant. R454B is a next generation A2L refrigerant with a GWP of only 467, one of the lowest on the market. This GWP value ensures that the MLE range complies with the gradual reduction of greenhouse gas emissions required by the F-GAS regulation. The range consists of 12 models with cooling capacities ranging from 40 to 240 kW, available for 2+2 pipe (M version) or 4 pipe (P version) systems. The main strong point of the range is the high seasonal efficiency, aimed at definitively reducing annual energy consumption, as well as offering the possibility of satisfying the thermal load, cooling and domestic hot water production of a building with a unique solution. In order to increase the efficiency at partial loads, all MLE models are equipped with dual-circuit solutions, using up to 4 scroll compressors with IDV (intermediate discharge valve) as standard, the units are equipped with an electronic expansion valve. The use of top quality components at the cutting edge of technology in the cooling, hydraulic, and electrical systems makes MLE units state of the art in terms of efficiency, reliability, and operating limits. In fact, the ability to produce water from 5°C to 55°C, and full load operation with external air from -15°C to 45°C.

The range allows high configurability from an acoustic point of view, having a wide range of accessories designed to reduce noise emissions, and hydraulic, with the possibility of integrating up to 4 pumps on board (2 user side and 2 recovery side) and an inertial buffer tank. The advanced control, always present in the whole range, allows a continuous monitoring of the operating parameters, advanced adjustment logics, and connectivity with the most common protocols.

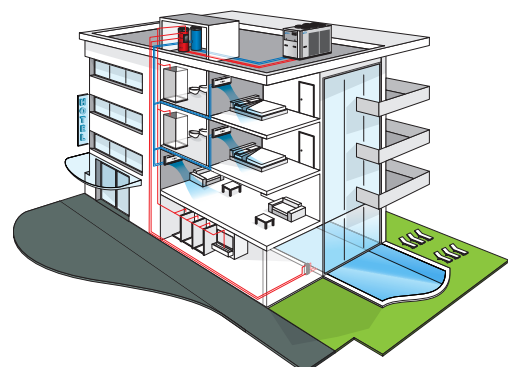

CONFIGURATOR

The models are completely configurable by selecting the version and the options. To the right is shown an example of configuration.

Version	Field	1	2	3	4	5	6	7	8	9	10	11	12	13
MLE174PS2A		A	0	0	0	E	E	0	0	0	0	0	0	1

To verify the compatibility of the options, use the selection software or the price list.

AVAILABLE VERSIONS

2 pipes systems version

MLE..MS2A

Power supply 400V-3N-50Hz + circuit breaker

MLE..MS5A

Power supply 400V-3-50Hz + circuit breaker

4 pipes systems version

MLE..PS2A

Power supply 400V-3N-50Hz + circuit breaker

MLE..PSSA

Power supply 400V-3-50Hz + circuit breaker

CONFIGURATION OPTIONS

1 Expansion valve

A Electronic

2 User side water pump

0 Absent

1 Single standard pump

2 Double std pump - OR

3 Single HP pump

4 Double HP pump - OR

A Single inverter standard pump

B Standard double inverter pump - (excludes inverter pump recovery side)

C Inverter Single HP pump

D HP double inverter pump - OR (excludes inverter pump recovery side)

3 Water buffer tank

0 Absent

R Selected recovery side

S Selected user side

4 Recovery water pump

0 Absent

1 Single standard pump

2 Double std pump - OR

3 Single HP pump

4 HP double pump - OR

A Single inverter standard pump

B Std single inverter pump - OR (excludes inverter pump user side)

C Inverter Single HP pump

D HP double inverter pump - OR (excludes inverter pump user side)

5 Air flow modulation

A with EC Fans high pressure head (not available up to size 114)

C With phase-cut (not available up to size 114)

E with EC Fans (supplied up to size 114)

6 Antifreezing kit

E Only plate exchanger (supplied user and recovery)

P Plate exchanger and pump

S For plate exchanger, pump, tank and expansion vessel.

T Plate exchanger, tank and expansion vessel

7 Acoustic insulation and attenuation

0 Absent

3 Compressor compartment acoustic insulation and sound blanket

6 Compressor soundproof insulations + Low-noise EC fans

8 Remote communication

0 Absent

2 RS485 connection port (Modbus protocol or Carel)

B BACNET IP / pCOWeb serial board

G BACNET IP / pCOWeb serial board + supervision software

9 Remote control

0 Absent

S Remote simplified control panel

X Remote control panel for advanced controller

10 Special coils / Protective treatments

0 Copper - aluminium (standard)

C Cataphoresis

I Hydrophilic

P Pre-painted fins with epoxy painting

R Copper-copper

11 Anti vibration shock mounts

0 Absent

G Made of rubber

M With spring

12 Outdoor coil trace heater and unit base

0 Absent

1 Selected

13 Onboard controller

1 Advanced

ACCESSORIES

A Outdoor finned coil heat exchanger protection filters

B Outdoor finned coil heat exchanger protection grille

C Two pairs of Victaulic joints (from size 104)

D ON/OFF status of the compressors

E Remote control for step capacity limit (advanced controller required)

F Configurable digital alarm board (advanced controller required)

G Soft starter

H Power factor capacitors

I Refrigerant sensors (standard)

L Refrigerant filter regulating kit

M 0-10V signal for external user and recovery pumps control (only if field 2 = 0 and field 4 = 0)

N Compressor isolation valves

O Night-time low-noise

Q Couple of probes for buffer tank temperature regulation (user and recovery)

R Enabling 2nd set-point / external alarm signaling via digital input

S Hot-wire electronic flow switch

T Energy metering kit

U Unit lifting pipes (up to size 94)

V Set-point modification with 4-20mA signal

OPERATING RANGE

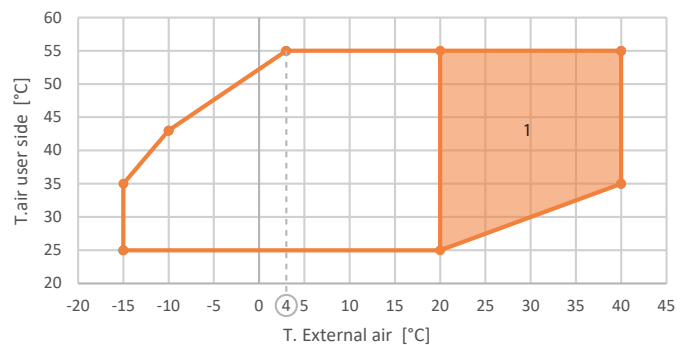
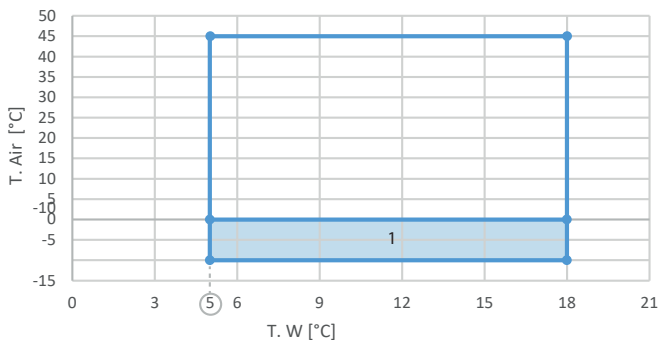

Total heat recovery multi-purpose units

Very low GWP refrigerant

Use of R454B refrigerant with low environmental impact. R454B is a next-generation A2L refrigerant with a GWP of only 467, one of the lowest on the market. This GWP value ensures that the MLE range complies with the gradual reduction of quotas of greenhouse refrigerants in the European market required by the F-GAS regulation.

Electronic valve

It is standard on the entire range and offers greater responsiveness during transients. The electronics also manage the synergistic operation of the compressors and the valve, thereby making it possible to vary overheating and maximize efficiency at partial loads.



Scroll compressors

The scroll-type compressors designed to work with R454B, which can be sound insulated, include internal thermal protection of the windings and are installed on special anti-vibration supports. The scroll-type compressors are equipped with an IDV valve. The IDV intermediate delivery valve technology allows the compressor to avoid losses caused by overcompression and, consequently, the additional work the motor has to perform in partial-load operation, thus saving energy and improving seasonal and partial-load efficiency from 3% to 10%.



Safety procedures in case of refrigerant leakage

As a standard feature, the units are equipped with leak detection sensors near the cooling circuit. The microprocessor manages the procedures for securing and shutting down the unit in case of refrigerant leakage, also making it possible to divert the power supply of the control unit that collects the information from the leak sensors on a low-voltage emergency line. This function allows the complete disconnection of the power to the unit during maintenance operations, while leaving all the safety systems enabled.



Economy - low noise function

Based on time slots or no-voltage contact, this function makes it possible to reduce the maximum speed of fans and the number of compressors that can be activated. This operation is especially useful during the night phase, when the power required is very low, and the unit can operate at a reduced level, thus lowering the noise level during a sensitive time period.

Low noise execution

The units can be supplied in a low-noise version, with noise-canceling headsets for compressors, and additional acoustic insulation to the fridge compartment. This configuration, combined with the night attenuation function, provides a large reduction in the sound power level.

Primary heat pump management

In case of a decoupled circuit, it is possible, via remote sensor, to switch off the primary circuit's pumps, when permitted, due to low thermal load. In this manner a further reduction in pumping costs is achieved.

Power analyzer

Integrated inside the electrical panel, it includes current transformers and control unit. It allows the continuous monitoring of consumption and the main electrical quantities, then made available for any BMS system via serial port, as well as the limitation of the power absorbed when this exceeds a threshold value set by the user.

RATED TECHNICAL DATA MLE P

MLE			41	51	61	84	94	104
Power supply		V-ph-Hz	400-3N-50					
Cooling mode operation								
Cooling capacity	(1)(E)	kW	40,0	50,9	57,9	80,0	88,9	101
Total power input	(1)(E)	kW	14,0	18,6	20,8	28,5	33,6	37,3
EER	(1)(E)		2,85	2,74	2,78	2,80	2,65	2,71
Water flow	(1)	l/h	6879	8754	9959	13760	15311	17382
Water pressure drop	(1)(E)	kPa	16	25	31	32	39	31
Available pressure head - LP pumps	(1)	kPa	170	152	140	124	103	120
Available pressure head - HP pumps	(1)	kPa	204	187	176	192	179	178
Cooling and heating mode in total heat recovery								
Cooling capacity	(2)(E)	kW	38,9	51,5	58,3	75,3	88,5	101
Heating capacity	(2)(E)	kW	52,4	69,2	78,9	103	121	137
Total power input	(2)(E)	kW	12,4	16,2	18,6	25,5	29,4	32,7
TER	(2)(E)		7,35	7,45	7,36	7,00	7,12	7,28
Available pressure head LP pumps user side		kPa	170	154	143	117	103	121
Available pressure head HP pumps user side		kPa	205	189	178	188	179	180
Available pressure head LP pump total recovery side		kPa	166	147	132	112	89	105
Available pressure head HP pump total recovery side		kPa	201	182	167	185	170	163
Heating mode operation								
Heating capacity	(3)(E)	kW	45,2	58,1	67,7	89,4	103	119
Total power input	(3)(E)	kW	13,9	17,4	19,9	27,6	31,3	35,2
COP	(3)(E)		3,26	3,33	3,41	3,24	3,28	3,39
SCOP	(4)		3,54	3,61	3,62	3,70	3,75	3,75
Water flow	(3)	l/h	7842	10083	11743	15493	17788	20674
Water pressure drop	(3)(E)	kPa	18	29	38	36	46	43
Available pressure head - LP pumps	(3)	kPa	164	142	128	109	82	104
Available pressure head - HP pumps	(3)	kPa	198	177	163	183	166	162
General data								
Maximum current absorption		A	40,0	50,0	54,0	74,0	86,0	98,0
Start up current		A	98	142	147	98	142	142
Startup current with soft starter		A	69	99	103	69	99	99
Compressors / circuits			2/2	2/2	2/2	4/2	4/2	4/2
Expansion vessel volume		dm ³	8	8	8	8	8	12
Buffer tank volume		dm ³	125	125	125	200	200	315
Sound power level	(5)(E)	dB(A)	83	83	83	84	85	86
Weight without options		kg	690	705	715	960	985	1350
Maximum transport weight		kg	782	798	809	1092	1121	1458

(1) Outdoor air temperature 35°C, water temperature 12°C / 7°C (EN14511:2022)

(2) Cooling water temperature 7°C, water flow rate same as in cooling mode; Recovery water temperature 45°C, water flow rate same as in heating mode

(3) Outdoor air temperature dry bulb 7°C / wet bulb 6°C, water temperature 40°C / 45°C (EN14511:2022)

(4) η efficiency values for heating and cooling are respectively calculated by the following formulas: $[\eta = SCOP / 2,5 - F(1) - F(2)]$ e $[\eta = SEER / 2,5 - F(1) - F(2)]$. For further information, please refer to the technical document "ErP 2009/125/EC DIRECTIVE" in the catalogue introducing pages, or to the EN14825:2022 regulation. Low temperature conditions.

(5) Sound power level measured according to ISO 9614

(E) EUROVENT certified data

Total heat recovery multi-purpose units

RATED TECHNICAL DATA MLE P

MLE			114	144	154	174	204	244
Power supply		V-ph-Hz	400-3N-50					
Cooling mode operation								
Cooling capacity	(1)(E)	kW	119	137	150	170	200	234
Total power input	(1)(E)	kW	42,7	48,4	55,0	65,4	75,8	92,0
EER	(1)(E)		2,79	2,83	2,73	2,60	2,64	2,54
Water flow	(1)	l/h	20491	23570	25823	29266	34424	40218
Water pressure drop	(1)(E)	kPa	41	28	33	41	31	41
Available pressure head - LP pumps	(1)	kPa	107	184	168	141	148	113
Available pressure head - HP pumps	(1)	kPa	166	307	290	263	197	163
Cooling and heating mode in total heat recovery								
Cooling capacity	(2)(E)	kW	115	134	150	174	202	244
Heating capacity	(2)(E)	kW	156	180	201	234	271	326
Total power input	(2)(E)	kW	37,6	41,9	46,5	55,4	63,0	76,4
TER	(2)(E)		7,21	7,51	7,53	7,37	7,51	7,45
Available pressure head LP pumps user side		kPa	102	183	168	142	153	123
Available pressure head HP pumps user side		kPa	161	306	290	265	202	173
Available pressure head LP pump total recovery side		kPa	91	170	153	121	142	103
Available pressure head HP pump total recovery side		kPa	149	292	274	242	191	153
Heating mode operation								
Heating capacity	(3)(E)	kW	134	154	168	193	225	268
Total power input	(3)(E)	kW	39,8	47,3	52,1	60,8	71,9	84,2
COP	(3)(E)		3,36	3,26	3,22	3,17	3,13	3,18
SCOP	(4)		3,80	3,70	3,71	3,70	3,60	3,65
Water flow	(3)	l/h	23166	26732	29153	33439	39120	46430
Water pressure drop	(3)(E)	kPa	53	36	42	54	35	48
Available pressure head - LP pumps	(3)	kPa	87	163	142	105	129	84
Available pressure head - HP pumps	(3)	kPa	145	285	263	227	178	134
General data								
Maximum current absorption		A	106	115	127	145	165	193
Start up current		A	147	158	197	215	215	260
Startup current with soft starter		A	103	111	138	150	150	182
Compressors / circuits			4/2					
Expansion vessel volume		dm ³	12	24	24	24	24	24
Buffer tank volume		dm ³	315	600	600	600	600	600
Sound power level	(5)(E)	dB(A)	86	85	85	87	89	89
Weight without options		kg	1355	1795	1810	1895	2320	2320
Maximum transport weight		kg	1464	1988	2000	2090	2560	2562

(1) Outdoor air temperature 35°C, water temperature 12°C / 7°C (EN14511:2022)

(2) Cooling water temperature 7°C, water flow rate same as in cooling mode; Recovery water temperature 45°C, water flow rate same as in heating mode

(3) Outdoor air temperature dry bulb 7°C / wet bulb 6°C, water temperature 40°C / 45°C (EN14511:2022)

(4) η efficiency values for heating and cooling are respectively calculated by the following formulas: $[\eta = SCOP / 2,5 - F(1) - F(2)]$ e $[\eta = SEER / 2,5 - F(1) - F(2)]$. For further information, please refer to the technical document "ErP 2009/125/EC DIRECTIVE" in the catalogue introducing pages, or to the EN14825:2022 regulation. Low temperature conditions.

(5) Sound power level measured according to ISO 9614

(E) EUROVENT certified data

RATED TECHNICAL DATA MLE M

MLE			41	51	61	84	94	104
Power supply		V-ph-Hz	400-3N-50					
Cooling mode operation								
Cooling capacity	(1)(E)	kW	40,0	50,9	57,9	80,0	88,9	101
Total power input	(1)(E)	kW	14,0	18,6	20,8	28,5	33,6	37,3
EER	(1)(E)		2,85	2,74	2,78	2,80	2,65	2,71
Water flow	(1)	l/h	6879	8754	9959	13760	15311	17382
Water pressure drop	(1)(E)	kPa	16	25	31	32	39	31
Available pressure head - LP pumps	(1)	kPa	170	152	140	124	103	120
Available pressure head - HP pumps	(1)	kPa	204	187	176	192	179	178
Cooling and heating mode in total heat recovery								
Cooling capacity	(2)(E)	kW	38,9	51,5	58,3	75,3	88,5	101
Heating capacity	(2)(E)	kW	52,4	69,2	78,9	103	121	137
Total power input	(2)(E)	kW	12,4	16,2	18,6	25,5	29,4	32,7
TER	(2)(E)		7,35	7,45	7,36	7,00	7,12	7,28
Available pressure head LP pumps user side		kPa	170	154	143	117	103	121
Available pressure head HP pumps user side		kPa	205	189	178	188	179	180
Available pressure head LP pump total recovery side		kPa	166	147	132	112	89	105
Available pressure head HP pump total recovery side		kPa	201	182	167	185	170	163
Heating mode operation								
Heating capacity	(3)(E)	kW	44,1	56,8	66,2	87,3	100	116
Total power input	(3)(E)	kW	14,8	18,5	21,1	29,4	33,3	37,4
COP	(3)(E)		2,98	3,07	3,14	2,97	3,01	3,11
SCOP	(4)		3,54	3,61	3,62	3,70	3,75	3,75
Water flow	(3)	l/h	7658	9853	11471	15140	17345	20177
Water pressure drop	(3)(E)	kPa	18	28	36	35	44	41
Available pressure head - LP pumps	(3)	kPa	166	144	131	112	88	107
Available pressure head - HP pumps	(3)	kPa	200	179	166	185	169	165
General data								
Maximum current absorption		A	40,0	50,0	54,0	74,0	86,0	98,0
Start up current		A	98	142	147	98	142	142
Startup current with soft starter		A	69	99	103	69	99	99
Compressors / circuits			2/2	2/2	2/2	4/2	4/2	4/2
Expansion vessel volume		dm ³	8	8	8	8	8	12
Buffer tank volume		dm ³	125	125	125	200	200	315
Sound power level	(5)(E)	dB(A)	83	83	83	84	85	86
Weight without options		kg	690	705	715	960	985	1350
Maximum transport weight		kg	782	798	809	1092	1121	1458

(1) Outdoor air temperature 35°C, water temperature 12°C / 7°C (EN14511:2022)

(2) Cooling water temperature 7°C, water flow rate same as in cooling mode; Recovery water temperature 45°C, water flow rate same as in heating mode

(3) Outdoor air temperature dry bulb 7°C / wet bulb 6°C, water temperature 40°C / 45°C (EN14511:2022)

(4) η efficiency values for heating and cooling are respectively calculated by the following formulas: $[\eta = SCOP / 2,5 - F(1) - F(2)]$ e $[\eta = SEER / 2,5 - F(1) - F(2)]$. For further information, please refer to the technical document "ErP 2009/125/EC DIRECTIVE" in the catalogue introducing pages, or to the EN14825:2022 regulation. Low temperature conditions.

(5) Sound power level measured according to ISO 9614

(E) EUROVENT certified data

Total heat recovery multi-purpose units

RATED TECHNICAL DATA MLE M

MLE			114	144	154	174	204	244
Power supply		V-ph-Hz	400-3N-50					
Cooling mode operation								
Cooling capacity	(1)(E)	kW	119	137	150	170	200	234
Total power input	(1)(E)	kW	42,7	48,4	55,0	65,4	75,8	92,0
EER	(1)(E)		2,79	2,83	2,73	2,60	2,64	2,54
Water flow	(1)	l/h	20491	23570	25823	29266	34424	40218
Water pressure drop	(1)(E)	kPa	41	28	33	41	31	41
Available pressure head - LP pumps	(1)	kPa	107	184	168	141	148	113
Available pressure head - HP pumps	(1)	kPa	166	307	290	263	197	163
Cooling and heating mode in total heat recovery								
Cooling capacity	(2)(E)	kW	115	134	150	174	202	244
Heating capacity	(2)(E)	kW	156	180	201	234	271	326
Total power input	(2)(E)	kW	37,6	41,9	46,5	55,4	63,0	76,4
TER	(2)(E)		7,21	7,51	7,53	7,37	7,51	7,45
Available pressure head LP pumps user side		kPa	102	183	168	142	153	123
Available pressure head HP pumps user side		kPa	161	306	290	265	202	173
Available pressure head LP pump total recovery side		kPa	91	170	153	121	142	103
Available pressure head HP pump total recovery side		kPa	149	292	274	242	191	153
Heating mode operation								
Heating capacity	(3)(E)	kW	130	150	164	189	221	262
Total power input	(3)(E)	kW	42,4	50,2	55,4	64,7	76,5	89,8
COP	(3)(E)		3,08	2,99	2,96	2,91	2,89	2,92
SCOP	(4)		3,80	3,70	3,71	3,70	3,60	3,65
Water flow	(3)	l/h	22603	26052	28405	32719	38351	45543
Water pressure drop	(3)(E)	kPa	50	34	40	52	34	47
Available pressure head - LP pumps	(3)	kPa	91	168	147	112	133	90
Available pressure head - HP pumps	(3)	kPa	149	289	268	233	182	139
General data								
Maximum current absorption		A	106	115	127	145	165	193
Start up current		A	147	158	197	215	215	260
Startup current with soft starter		A	103	111	138	150	150	182
Compressors / circuits			4/2					
Expansion vessel volume		dm ³	12	24	24	24	24	24
Buffer tank volume		dm ³	315	600	600	600	600	600
Sound power level	(5)(E)	dB(A)	86	85	85	87	89	89
Weight without options		kg	1355	1795	1810	1895	2320	2320
Maximum transport weight		kg	1464	1988	2000	2090	2560	2562

(1) Outdoor air temperature 35°C, water temperature 12°C / 7°C (EN14511:2022)

(2) Cooling water temperature 7°C, water flow rate same as in cooling mode; Recovery water temperature 45°C, water flow rate same as in heating mode

(3) Outdoor air temperature dry bulb 7°C / wet bulb 6°C, water temperature 40°C / 45°C (EN14511:2022)

(4) η efficiency values for heating and cooling are respectively calculated by the following formulas: $[\eta = SCOP / 2,5 - F(1) - F(2)]$ e $[\eta = SEER / 2,5 - F(1) - F(2)]$. For further information, please refer to the technical document "ErP 2009/125/EC DIRECTIVE" in the catalogue introducing pages, or to the EN14825:2022 regulation. Low temperature conditions.

(5) Sound power level measured according to ISO 9614

(E) EUROVENT certified data

DIMENSIONAL DRAWINGS

MLE 41 - 51 - 61

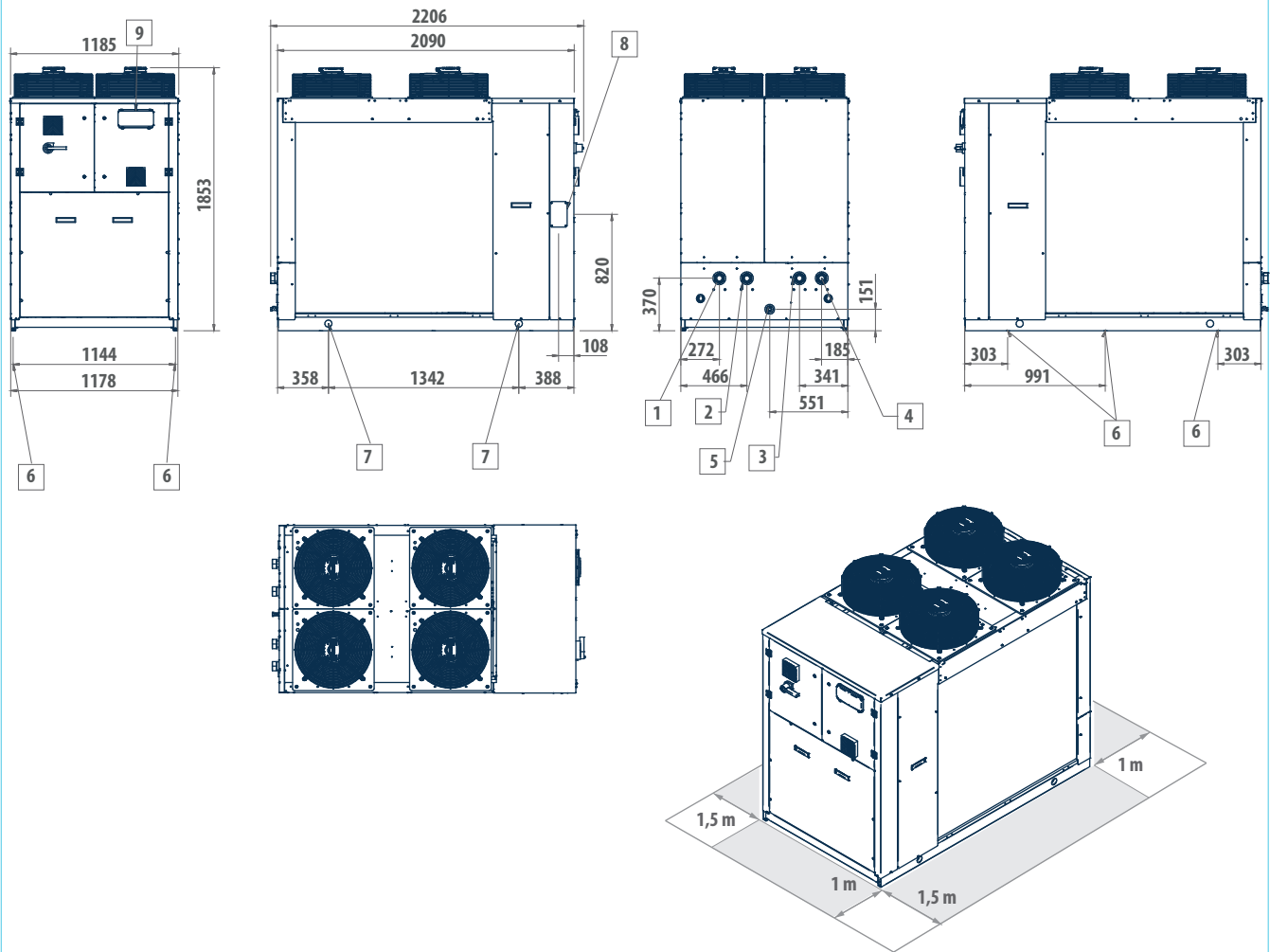

LEGEND

1	Water inlet on user side 2" F
2	Water outlet user 2" F
3	Heat recovery hot water inlet 2" F
4	Recovery hot water outlet recovery 2" F
5	Water drainage tank 1/2" F
6	Vibration dumpers
7	Lifting points
8	Power supply input
9	User interface

DIMENSIONAL DRAWINGS

MLE 84 - 94

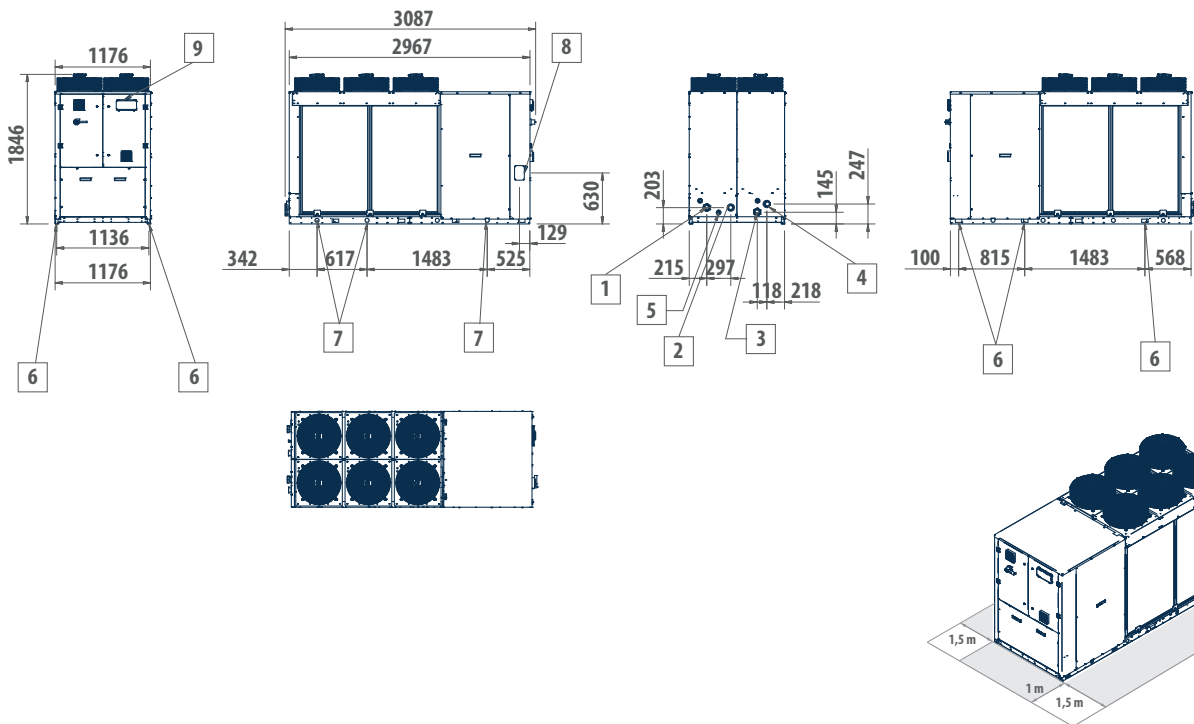

LEGEND

1	Water inlet on user side 2" 1/2 F
2	Water outlet user 2" 1/2 F
3	Heat recovery hot water inlet 2" 1/2 F
4	Recovery hot water outlet recovery 2" 1/2 F
5	Water drainage tank 1/2" F
6	Vibration dumpers
7	Lifting points
8	Power supply input
9	User interface

DIMENSIONAL DRAWINGS

MLE 104 - 114

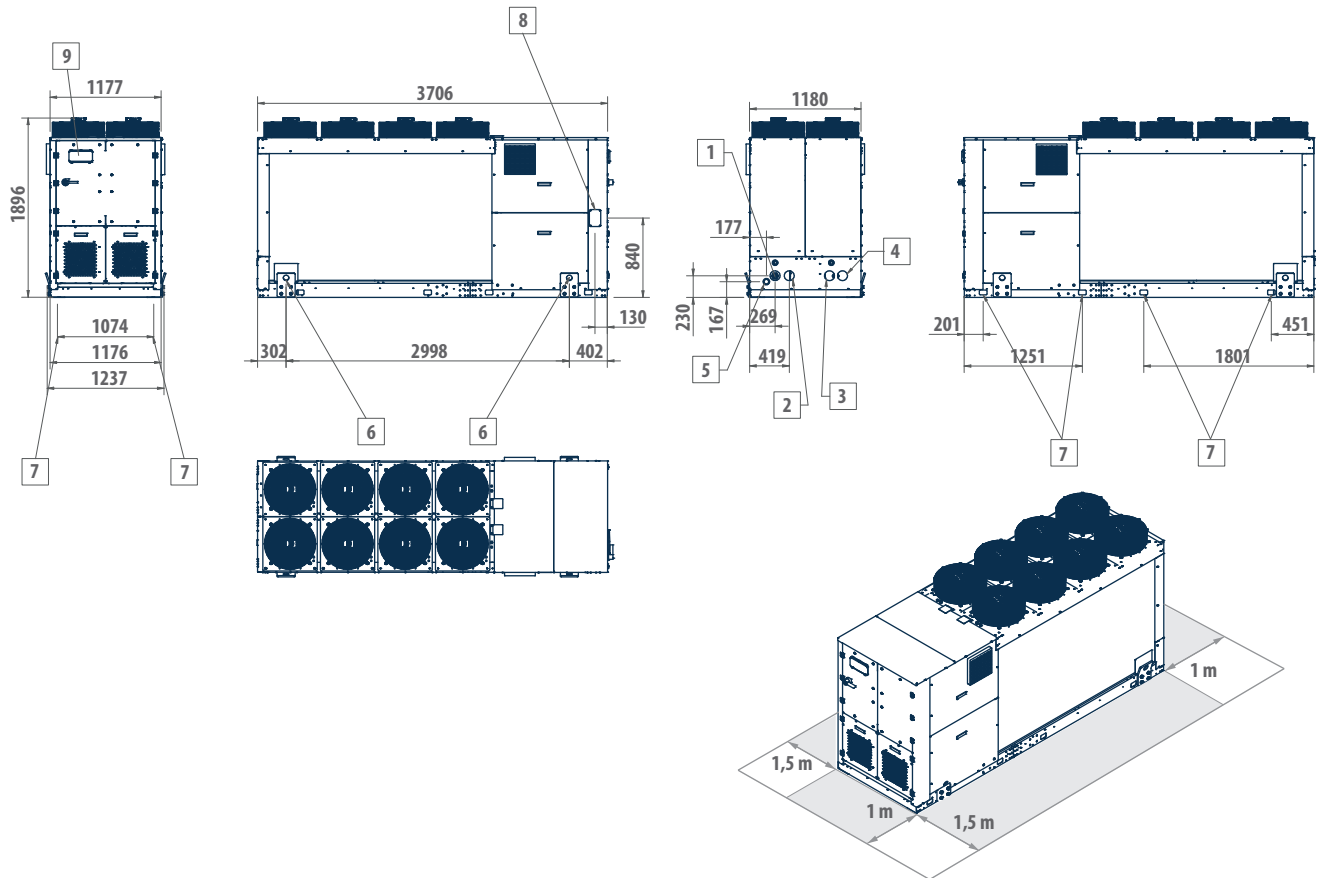

LEGEND

1	Water inlet on user side 2 1/2" VIC
2	Water outlet user 2 1/2" VIC
3	Heat recovery hot water inlet 2 1/2" VIC
4	Recovery hot water outlet recovery 2 1/2" VIC
5	Water drainage tank 1/2" F
6	Lifting points
7	Vibration dumpers
8	Power supply input
9	User interface

Total heat recovery multi-purpose units

DIMENSIONAL DRAWINGS

MLE 144 - 154 - 174

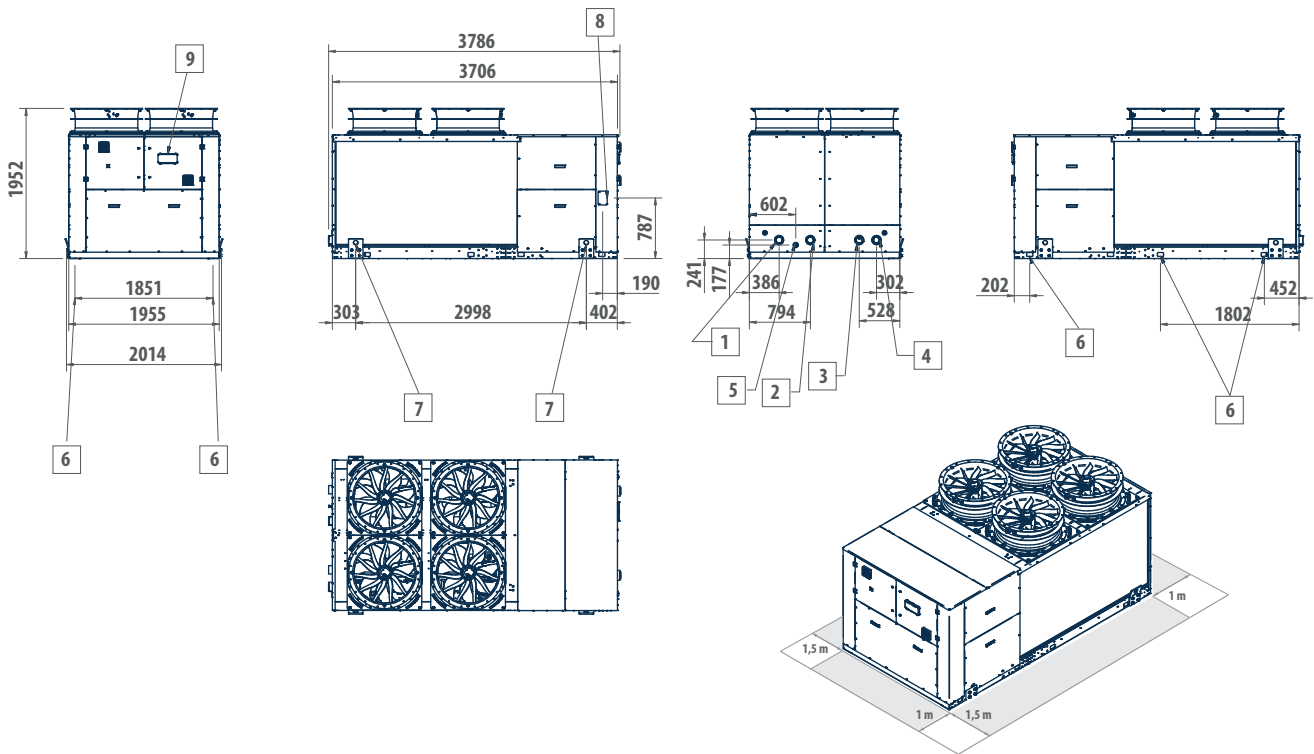

LEGEND

1	Water inlet on user side 3" VIC
2	Water outlet user 3" VIC
3	Heat recovery hot water inlet 3" VIC
4	Recovery hot water outlet recovery 3" VIC
5	Water drainage tank 1/2 " F
6	Vibration dumpers
7	Lifting points
8	Power supply input
9	User interface

DIMENSIONAL DRAWINGS

MLE 204 - 244

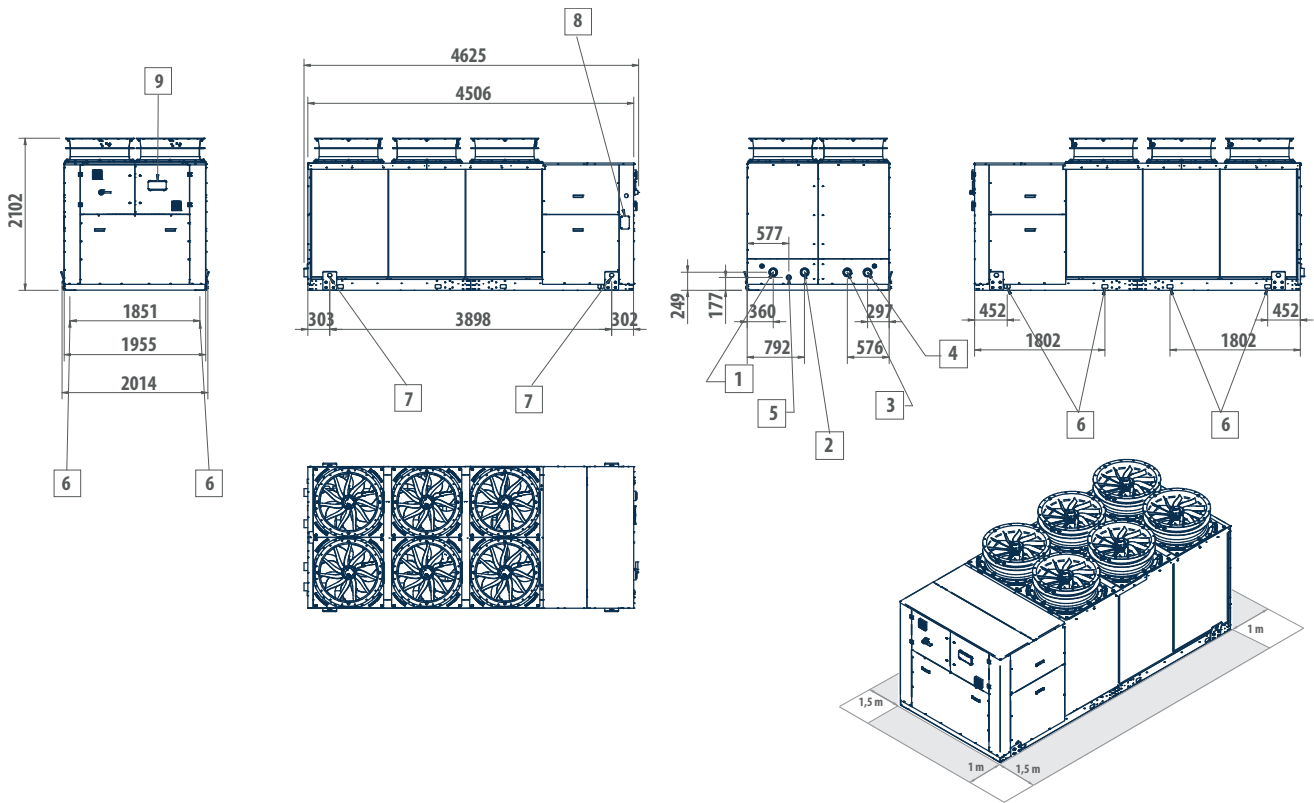

LEGEND

1	Water inlet on user side 3" VIC
2	Water outlet user 3" VIC
3	Heat recovery hot water inlet 3" VIC
4	Recovery hot water outlet recovery 3" VIC
5	Water drainage tank 1/2" F
6	Vibration dumpers
7	Lifting points
8	Power supply input
9	User interface

Total heat recovery multi-purpose units with low GWP refrigerant - MLE

Outdoor packaged unit with R290

PLN P 50 - 150 kW



Scroll compressor



R-290 Refrigerant



A3 gas leak detection



Multi-purpose 4 pipes system



Heating/Cooling

Outdoor packaged air-water polyvalent units with R290 refrigerant and multi-scroll compressors

The reduction of polluting emissions, whether directly related to the use of greenhouse gases or more indirectly related to emissions from the production of electricity used during the lifetime of a heat pump, is the first and most important pillar on which Galletti has based its Advanced Design solutions.

This journey led to the creation of PLN P, a new range of air-water units with total heat recovery, natural refrigerant, and multi-scroll solutions. Its extremely wide operating range and high performance under all operating conditions make it the ideal answer to the growing need to gradually move away from fossil energy sources for the heating and cooling of buildings.

Thanks to the high temperature of the water produced (up to 78°C), we can replace a fossil fuel generator while maintaining the full performance of the existing emissions system.

By leveraging multi-scroll configurations (with up to 4 compressors), we produce exactly what is needed at any given moment to ensure people's comfort no more, no less while working to maximize the overall system efficiency.

We look to the future of our environment as well as the needs of the people who use our products.

We work every day to make indoor comfort more sustainable.

PLUS

- » R290 refrigerant (GWP=3)
- » Multi-scroll solutions
- » Low refrigerant charge (<10 kg for circuit)
- » Production of hot water up to 78°C
- » Full load operation down to -20°C air (50°C water)
- » Very high seasonal efficiency values
- » Total heat recovery
- » Availability of silenced setups

The PLN P multi-purpose units have been designed for cooling or heating water intended for air-conditioning and heating systems in residential, commercial, or industrial applications. The use of the natural refrigerant R290 (propane) ensures compliance with the more stringent limits imposed by the F-GAS regulation regarding gases with a potential contribution to global warming (greenhouse gases).

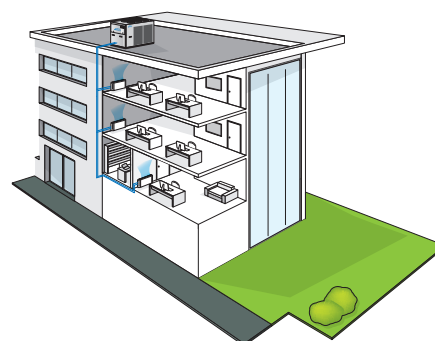

Natural refrigerant (R290)

R290 (propane) is a natural refrigerant with a GWP (Global Warming Potential) of only 3. This makes it a strong contender to be one of the leading refrigerants for air conditioning solutions. It has a much lower contribution to the greenhouse effect than synthetic refrigerants and physical properties that make it ideal for the design requirements associated with the ever-increasing use of heat pumps.

Scroll compressor

The new scroll compressor for R290 is designed for both single and parallel configurations, offering higher efficiency and extended durability. Featuring innovative elements such as intermediate discharge valves (IDV) for superior seasonal efficiency, lead-free polymer bearings for improved performance under low-lubrication conditions, and a patented motor for optimal cooling, this series sets a new benchmark in compressor technology. In addition, the internal non-return valve (INRV) minimizes the risk of leakage, while the brazed oil tube connection ensures leak-free operation.

EXTENDED OPERATING RANGE FOR EACH APPLICATION

Extremely extended operating limits

It is now clear that heat pumps will play a key role in achieving the objectives of the European Green Deal first and foremost, the phase-out of fossil fuels. One of the essential requirements for heat pumps to be considered a true alternative to boilers, even in the harshest climates, is undoubtedly the extension of the operating limits that have traditionally constrained conventional heat pumps. Thanks to the use of a new-generation scroll compressor technology, combined with propane as a natural refrigerant and the innovative solutions developed by the Advanced Design Unit of Galletti during the design and prototyping phase, PLN P ensures the ability to produce hot water at very high temperatures (up to 78 °C) and to operate at full load even at extremely low outdoor temperatures (down to -20 °C).

In this way (given the temperature levels achievable, unimaginable with a traditional heat pump) it becomes possible to replace a combustion generator with an R290 heat pump, even when building insulation improvements are postponed. This allows a significant increase in the share of renewable energy used for heating, without compromising indoor comfort.

Advanced Design's solutions look to the future of the environment and the needs of the people who use our products.

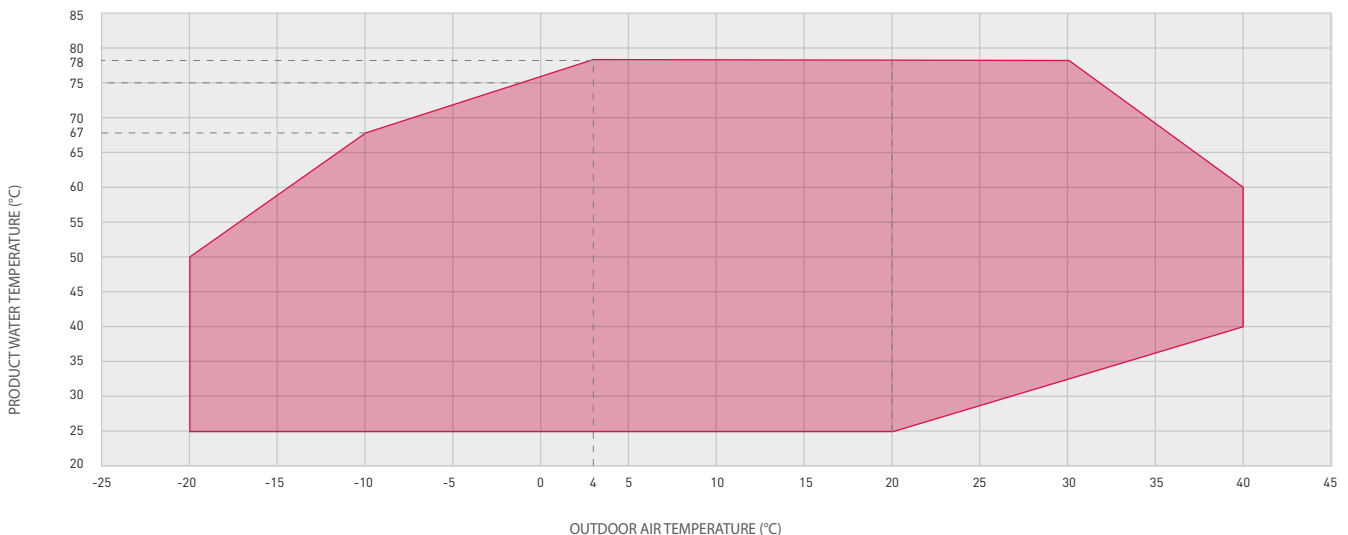

PLN P multi-purpose units with natural refrigerant

Multi-purpose units with natural refrigerant

CONFIGURATOR

The models are completely configurable by selecting the version and the options. To the right is shown an example of configuration.

Version	Field	1	2	3	4	5	6	7	8	9	10	11	12	13	14	15
PLN071PS2A	A	1	S	0	E	E	0	0	0	I	G	0	1	2	0	

To verify the compatibility of the options, use the online selection software or the price list.

AVAILABLE VERSIONS

Multipurpose versions with full recovery for 4-pipe systems

PLN..PS2A	Electrical supply 400V-3N-50Hz with circuit breakers
PLN..P55A	Electrical supply 400V-3-50Hz with circuit breakers

CONFIGURATION OPTIONS - PRELIMINARY

1 Expansion valve	0 Absent
A Electronic valve	S Remote simplified control panel
2 User side water pump	T Touch screen control (up to 50m)
0 Absent	X Additional remote control for advanced control (up to 50m)
1 Single standard pump	10 Special coils / Protective treatments
2 Double std pump - OR	0 Copper - aluminium
3 Single HP pump	C Cataphoresis
4 HP double pump - OR	I Hydrophilic
A Single inverter standard pump	P Pre-painted fins with epoxy painting
B Standard double inverter pump - OR (excludes inverter pump recovery side)	R Copper-copper
C Inverter Single HP pump	11 Base vibration dampers
D HP double inverter pump - OR (excludes inverter pump recovery side)	0 Absent
3 Water buffer tank	G Made of rubber
0 Absent	M With spring
R Selected recovery side	12 Outdoor coil trace heater and unit base
S Selected user side	0 Absent
4 Recovery water pump	1 Selected
0 Absent	13 Control panel
1 Single standard pump	1 Advanced
2 Double std pump - OR	2 Advanced with touch screen display
3 Single HP pump	14 Water flow control
4 HP double pump - OR	2 Vane-type flow switch
A Single inverter standard pump	3 Hot-wire electronic flow switch
B Std single inverter pump - OR (excludes inverter pump user side)	
C Inverter Single HP pump	
D HP double inverter pump - OR (excludes inverter pump user side)	
5 Condensation/Evaporation Control	
A With EC Fans high pressure head	
C With phase-cut (not available up to size 114)	
E With EC Fans (supplied up to size 114)	
6 Antifreezing kit	
E Only plate exchanger (supplied user and recovery)	
P Plate exchanger and pump	
S For plate exchanger, pump, tank and expansion vassel	
T Plate exchanger, tank and expansion vassel	
7 Acoustic insulation and attenuation	
0 Absent	
3 Compressor compartment acoustic insulation and sound blanket	
6 Compressor compartment acoustic insulation and sound blanket + Low-noise fans	
8 Remote communication	
0 Absent	
2 RS485 Board (Modbus protocol or Carel)	
B BACNET IP/pCOWeb serial board	
G BACNET IP / pCOWeb serial board + supervision software	
9 Remote control	
	B Outdoor finned coil heat exchanger protection grille
	D ON/OFF status of the compressors
	E Remote control for power step limits
	F Configurable digital alarm board
	G Soft starter
	H Power factor capacitors
	I Refrigerant sensors (standard)
	L Double insulation water side (as standard for tank)
	M 0-10V signal for external user pump control (only if opt 4 =0)
	N Integration system enabling contact (boiler / electric heater) plant
	O Night-time low-noise (only if opt 7 different from 6)
	Q Couple of probes for buffer tank temperature regulation (user and recovery)
	R Enabling 2nd set-point
	T Mains power analyzer for monitoring of power consumption
	V Set-point modification with 4-20mA signal
	3 2 Deaerators for hot and cold hydraulic circuits (supplied as an accessory)
	4 2 Dirt separators for hot and cold hydraulic circuits (supplied as an accessory)

ACCESSORIES



RATED TECHNICAL DATA PLN P

PLN P			051	071	081	104	114	134	154
Power supply		V-ph-Hz	400-3N-50						
Cooling mode operation									
Cooling capacity	(1)(E)	kW	50,8	63,0	73,0	103	115	125	147
Total power input	(1)(E)	kW	16,9	20,9	24,9	34,8	39,0	41,3	49,6
EER	(1)(E)		2,95	2,96	2,82	2,87	2,83	3,10	2,97
Water flow	(1)	l/h	8565	10652	12114	17206	19005	22025	25369
Water pressure drop	(1)(E)	kPa	25	34	41	48	57	32	38
Available pressure head - LP pumps	(3)	kPa	161	145	129	116	103	198	180
Available pressure head - HP pumps	(3)	kPa	195	180	165	175	162	322	303
Cooling and heating mode in total heat recovery									
Cooling capacity	(2)(E)	kW	50,8	63,0	73,0	103	115	125	147
Heating capacity	(2)(E)	kW	64,9	80,2	93,7	131	146	160	188
Total power input	(2)(E)	kW	15,1	18,2	21,9	30,2	33,9	36,4	43,1
TER	(2)(E)		7,68	7,86	7,62	7,71	7,71	7,82	7,80
Available pressure head LP pumps user side		kPa	163	149	133	120	111	200	183
Available pressure head HP pumps user side		kPa	197	184	168	179	169	324	307
Available pressure head LP pump total recovery side		kPa	157	139	118	114	99	190	170
Available pressure head HP pump total recovery side		kPa	191	173	152	172	157	313	292
Heating mode operation									
Heating capacity	(3)(E)	kW	54,2	67,8	78,2	106	121	135	156
Total power input	(3)(E)	kW	16,0	20,0	23,2	31,8	35,3	39,9	46,4
COP	(3)(E)		3,39	3,39	3,36	3,33	3,42	3,38	3,36
SCOP	(4)		3,10	3,05	3,06	3,25	3,36	3,16	3,30
SCOP	(5)		3,86	3,75	3,72	3,94	4,03	3,84	3,97
Heating energy efficiency class	(6)		A++	A+	A+	A++	A++	A++	A++
Heating energy efficiency class	(7)		A+	A+	A+	A++	A++	A+	A++
Water flow	(3)	l/h	9401	11759	13547	18321	20907	23362	27062
Water pressure drop	(3)(E)	kPa	25	35	45	48	59	33	40
Available pressure head - LP pumps	(3)	kPa	152	132	108	102	87	179	152
Available pressure head - HP pumps	(3)	kPa	187	167	144	160	145	301	273
General data									
Maximum current absorption		A	67,0	77,0	84,0	129	137	152	157
Start up current		A	187	240	247	249	264	315	320
Startup current with soft starter		A	143	181	188	205	217	256	261
Compressors / circuits			2/2	2/2	2/2	4/2	4/2	4/2	4/2
Buffer tank volume		dm ³	125	200	200	200	200	600	600
Sound power level	(8)(E)	dB(A)	84	85	85	85	86	87	87
Sound power level, low-noise version	(8)	dB(A)	81	82	82	82	83	84	84
Maximum transport weight		kg	1105	1348	1348	1863	1863	2694	2694

- (1) Outdoor air temperature 35°C, water temperature 12°C / 7°C (EN14511:2022)
- (2) Cooling water temperature 7°C, water flow rate same as in cooling mode; Recovery water temperature 45°C, water flow rate same as in heating mode
- (3) Outdoor air temperature dry bulb 7°C / wet bulb 6°C, water temperature 40°C / 45°C (EN14511:2022)
- (4) η efficiency values for heating and cooling are respectively calculated by the following formulas: $[\eta = SCOP / 2,5 - F(1) - F(2)]$ e $[\eta = SEER / 2,5 - F(1) - F(2)]$. For further information, please refer to the technical document "ErP 2009/125/EC DIRECTIVE" in the catalogue introducing pages, or to the EN14825:2022 regulation. Medium temperature conditions.
- (5) η efficiency values for heating and cooling are respectively calculated by the following formulas: $[\eta = SCOP / 2,5 - F(1) - F(2)]$ e $[\eta = SEER / 2,5 - F(1) - F(2)]$. For further information, please refer to the technical document "ErP 2009/125/EC DIRECTIVE" in the catalogue introducing pages, or to the EN14825:2022 regulation. Low temperature conditions.
- (6) Seasonal energy efficiency class for LOW TEMPERATURE room heating under AVERAGE climatic conditions [EUROPEAN REGULATION No 811/2013]
- (7) Seasonal energy efficiency class for MEDIUM TEMPERATURE room heating under AVERAGE climatic conditions [EUROPEAN REGULATION No 811/2013]
- (8) Sound power level measured according to ISO 9614
- (E) EUROVENT certified data

Multi-purpose units with natural refrigerant

DIMENSIONAL DRAWINGS

PLN P 51

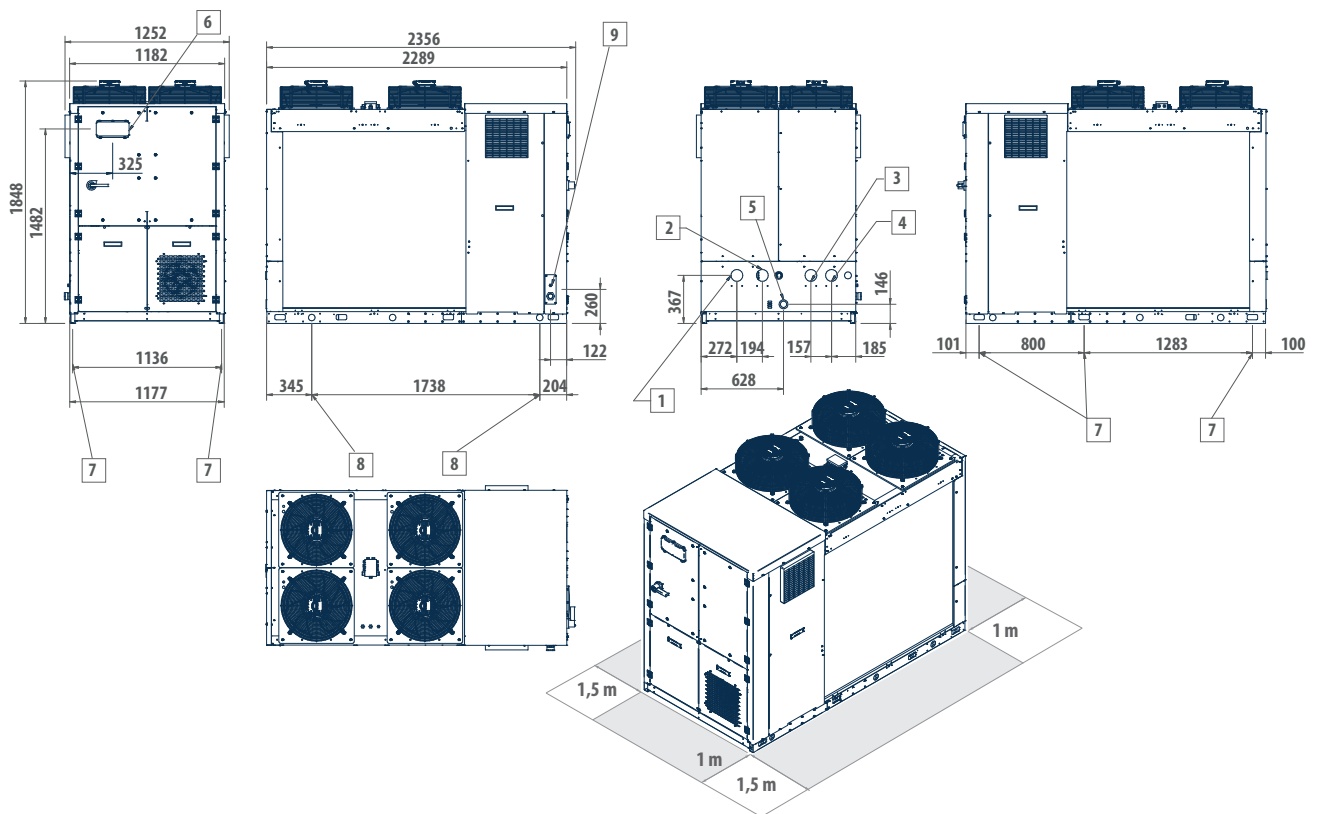

LEGENDA

1	Water inlet on user side 2" F
2	Water outlet user 2" F
3	Heat recovery hot water inlet 2" F
4	Recovery hot water outlet recovery 2" F
5	Water drainage tank 1/2" F
6	User interface
7	Vibration dampers
8	Lifting points
9	Power supply input

DIMENSIONAL DRAWINGS

PLN P 71 - 81

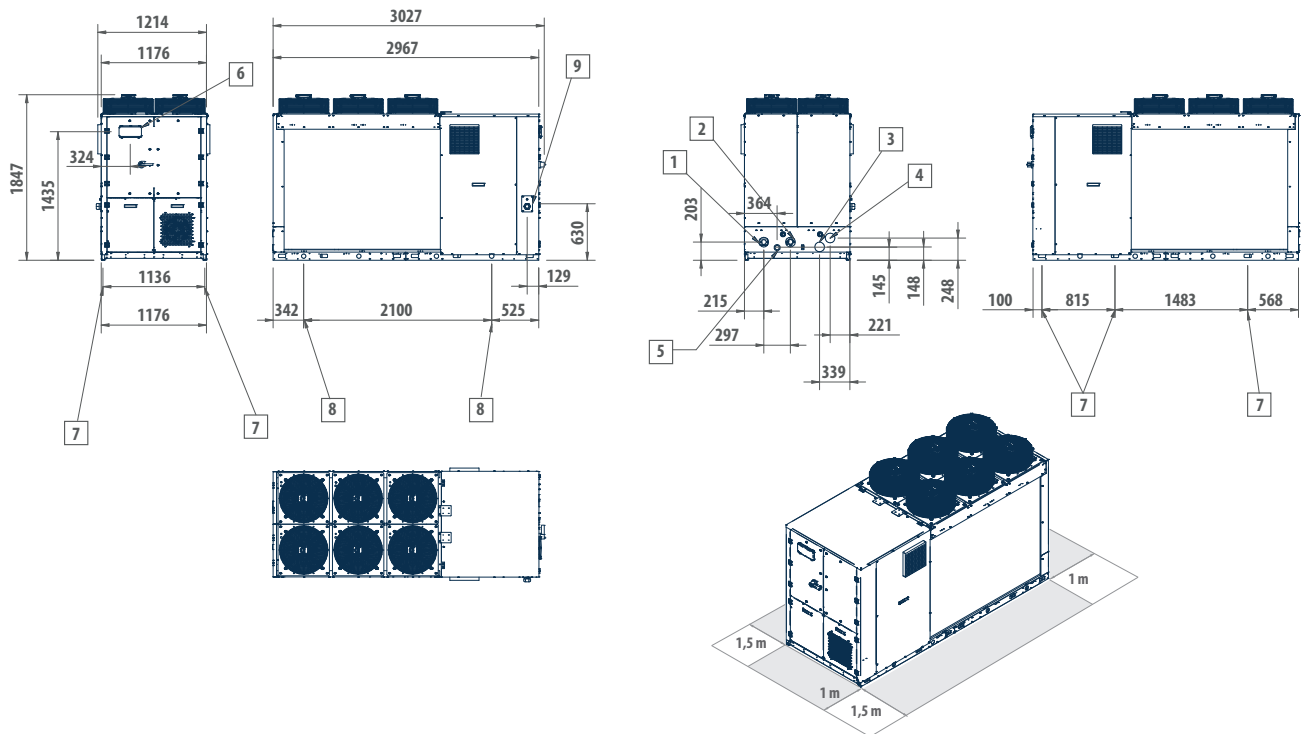

LEGENDA

1	Water inlet on user side 2" 1/2 F
2	Water outlet user 2" 1/2 F
3	Heat recovery hot water inlet 2" 1/2 F
4	Recovery hot water outlet recovery 2" 1/2 F
5	Water drainage tank 1/2 " F
6	User interface
7	Vibration dampers
8	Lifting points
9	Power supply input

PLN P multi-purpose units with natural refrigerant

Multi-purpose units with natural refrigerant

DIMENSIONAL DRAWINGS

PLN P 104 -114

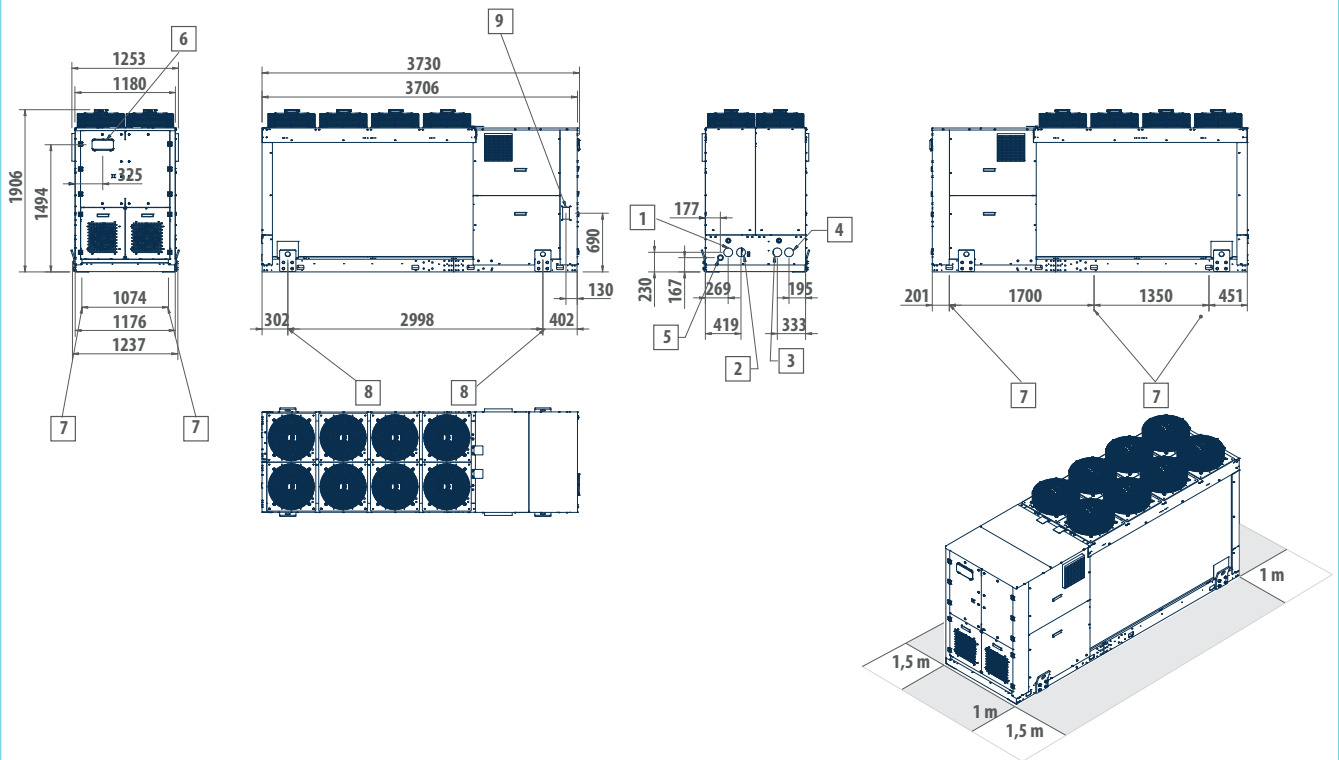

LEGENDA

1	Water inlet on user side 2" 1/2 F
2	Water outlet user 2" 1/2 F
3	Heat recovery hot water inlet 2" 1/2 F
4	Recovery hot water outlet recovery 2" 1/2 F
5	Water drainage tank 1/2" F
6	User interface
7	Vibration dampers
8	Lifting points
9	Power supply input

DIMENSIONAL DRAWINGS

PLN P 134 - 154

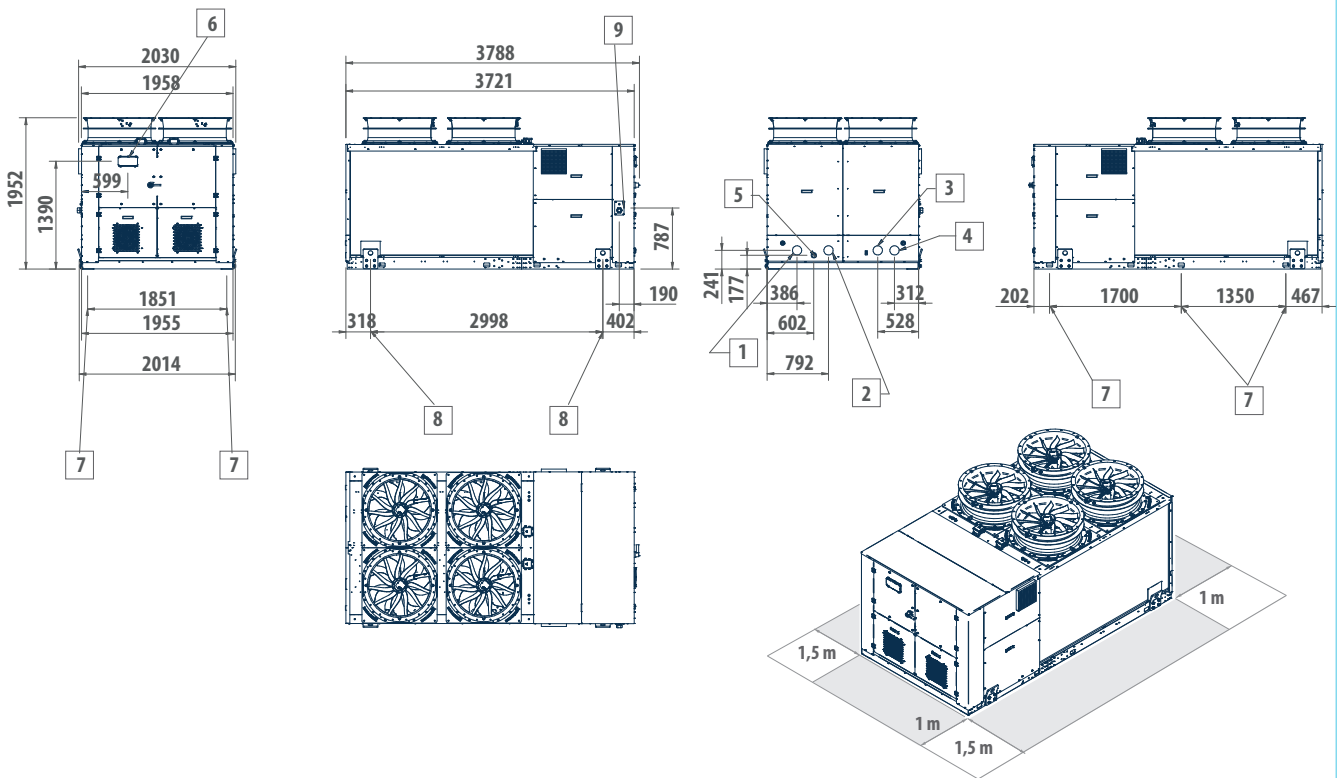

LEGENDA

1	Water inlet on user side 3" VIC
2	Water outlet user 3" VIC
3	Heat recovery hot water inlet 3" VIC
4	Recovery hot water outlet recovery 3" VIC
5	Water drainage tank 1/2 " F
6	User interface
7	Vibration dampers
8	Lifting points
9	Power supply input

Total heat recovery multi-purpose units LEP

Indoor packaged water-water unit

LEP 50 - 470 kW



Scroll
compressor



Refrigerant
R-410A



Heating/
Cooling



Total heat
recovery
multi-pur-
pose unit



Multi-purpose
2 pipes
system



Multi-purpose
4 pipes
system

Maximum efficiency with total recovery and dissipation in water.

LEP units are actually multi-purpose, they totally recover the condensation heat and they are characterized by the simultaneous production of cold and hot water. Available for two-pipe systems with the request of DHW production or in four-pipe systems, they are conceived for average-high power applications (multi residential or commercial unit) and they guarantee a high thermodynamic efficiency and a wide configurability both in terms of accessories and in terms of refrigeration cycle.

LEP series is characterized by a reduced size, high thermodynamic cycle COP, no external noise, reduced cooling load and it is composed of 24 models with refrigeration capacity ranging from 50 to 470 kW both for the standard version and the silenced one.

Multi-purpose LEP machines have six water connections linked to three different hydraulic circuits of which a dissipation one (hot or cold) opposed to the consumption. The users differ as for two-pipe system in which there is a hot/cold circuit and just one hot circuit for the production of DHW while in four-pipe systems there is one hot circuit and a cold one.

There is the option to obtain an external sound-proof hydraulic module with circulation pumps for dissipation circuits, users and domestic hot water.

PLUS

- » Maximum energy efficiency
- » Total condensation heat recovery
- » Electronic expansion valve
- » Up to 4 compressors
- » Remote connectivity with the most common protocols
- » Compact dimensions
- » Low-noise level thanks to the paneled structure

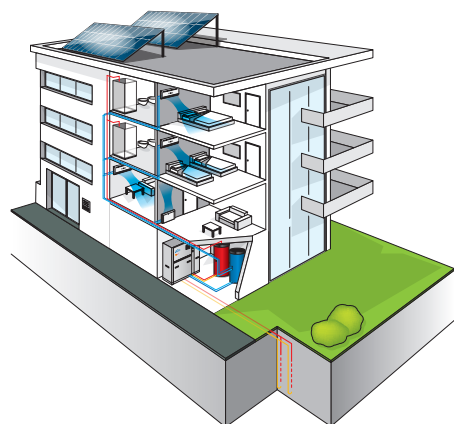

LEP is suitable to the air-conditioning of 2-pipe systems with production of DHW or in 4-pipe systems. In both, the total recovery of the heat ensures remarkable energy savings.

MAIN COMPONENTS

LEP-M: chiller mode

In the "Chiller" mode the unit cools water to air condition the interior on the user side, dissipating the condensation heat by means of water that is cooled in the dissipation exchanger.

LEP-M: chiller + DHW

In the "Chiller + DHW" mode the unit can produce chilled water with the simultaneous production of high-temperature hot water for sanitary use, thanks to total heat recovery.

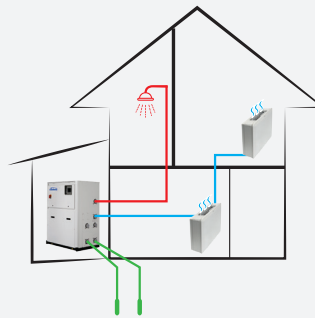

LEP-M: DHW mode

In the "high-temperature sanitary hot water (DHW)" mode the unit heats water in the condenser, dedicated to DHW as needed, dissipating the evaporative cooling capacity by means of water that is heated in the exchanger on the dissipation side.

LEP-M: heating pump mode

In the "heat pump" mode the unit heats the water in the condenser to warm the interior on the user side, dissipating the evaporative cooling capacity by means of water that is heated in the dissipation exchanger.

LEP-P: 4-pipes systems

The four-pipe system has a distribution system that offers both hot water (with respective return lines) and chilled water (with respective return lines). The LEP-P unit has a circuit used for the production of hot water and another one used for the production of cold water.

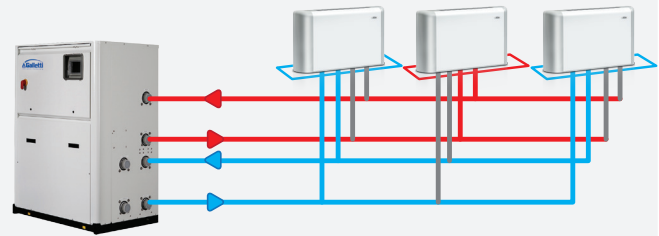

CONFIGURATOR

The models are completely configurable by selecting the version and the options. To the right is shown an example of configuration.

Version	Field	1	2	3	4	5	6	7	8	9
LEP214ML		2	B	P	0	2	G	0	0	B

To verify the compatibility of the options, use the selection software or the price list.

AVAILABLE VERSIONS

2 pipes systems version

LEP..MS Standard execution
LEP..ML Low noise execution

4 pipes systems version

LEP..PS Standard execution
LEP..PL Low noise execution

CONFIGURATION OPTIONS

- 1 Power supply**
 - 0 400 V - 3 N - 50 Hz
 - 2 400 V - 3 N - 50 Hz + magnetic breakers
- 2 Onboard controller and expansion valve**
 - B Advanced + electronic expansion valve
- 3 Source water flow modulation**
 - 0 Absent
 - P 0-10V signal for condensation control
- 4 User water flow modulation**
 - 0 Absent
 - D 0-10V signal for water flow adjustment with $\Delta T = \text{const}$ (advanced controller required)
 - T 0-10V signal for water flow adjustment with $T = \text{const}$ (advanced controller required)
- 5 Remote communication**
 - 0 Absent
 - 1 RS485 serial board (Carel / Modbus protocol)
 - 4 BACNET IP / PCOWEB serial board + supervision software Gweb (advanced controller required)
 - 5 BACNET IP / PCOWEB serial board + clock board + supervision software Gweb (advanced controller required)
- 6 Anti vibration shock mounts**
 - 0 Absent
 - G Rubber anti vibration shock mounts
 - M Spring anti vibration shock mounts
- 7 Packing**

- 0 Standard
- 1 Wooden cage
- 2 Wooden crate
- 8 Remote control**
 - 0 Absent
 - 3 Remote user panel for advanced controller
- 9 Insulated hydraulic module**
 - 0 Absent
 - A Water pumps LP user + LP inverter source + LP recovery
 - B Water pumps LP user + LP source + LP recovery
 - C Water pumps LP user + HP source + LP recovery
 - D Water pumps LP user + HP inverter source + LP recovery
 - E Water pumps HP user + LP source + LP recovery
 - F Water pumps HP user + LP inverter source + LP recovery
 - G Water pumps LP user + LP source + LP recovery
 - H Water pumps HP user + HP inverter source + LP recovery
 - I Water pumps LP user + LP inverter source + HP recovery
 - J Water pumps LP user + LP source + HP recovery
 - K Water pumps LP user + HP source + HP recovery
 - L Water pumps LP user + HP inverter source + HP recovery
 - M Water pumps HP user + HP source + HP recovery
 - N Water pumps HP user + LP inverter source + HP recovery
 - P Water pumps HP user + HP source + HP recovery
 - Q Water pumps HP user + HP inverter source + HP recovery

ACCESSORIES

A	Power factor capacitors	F	Refrigerant pressure gauges
B	Soft starter	G	Three couples of Victaulic joints
C	Service kit (advanced controller required)	H	Filter isolation valves kit (solenoid valve and isolation valve)
D	ON/OFF status of the compressors	I	4-way valve for water flow inversion on user side in the hydraulic module
E	Set point compensation outdoor temperature probe	L	Couple of probes for buffer tank temperature regulation

Total heat recovery multi-purpose units LEP

RATED TECHNICAL DATA FOR 2-PIPES + DHW SYSTEMS

LEP M			042	052	062	072	082	092
Power supply		V-ph-Hz	400 - 3N - 50					
Cooling mode operation								
Cooling capacity	(1)(E)	kW	46,4	53,4	63,6	69,4	80,6	93,1
Total power input	(1)(E)	kW	10,5	12,5	14,2	15,8	17,8	21,4
EER	(1)(E)		4,41	4,27	4,47	4,39	4,52	4,35
SEER	(2)		5,61	5,52	5,87	5,81	6,17	6,12
Water flow user side	(1)	l/h	7981	9187	10939	11939	13861	16015
Water pressure drop user side	(1)(E)	kPa	19	25	21	25	19	25
Water flow source side	(1)	l/h	9731	11254	13303	14553	16833	19555
Water pressure drop source side	(1)(E)	kPa	27	36	30	35	27	36
Cooling mode operation and DHW in total recovery								
Cooling capacity	(3)(E)	kW	41,5	46,7	57,0	61,8	71,9	83,4
Heating capacity	(4)(E)	kW	54,4	63,7	74,5	81,3	93,8	109
Total power input	(5)(E)	kW	12,6	15,0	17,0	18,9	21,3	25,2
COP HRE	(5)(E)		7,60	7,34	7,74	7,56	7,80	7,66
Water flow user side	(3)	l/h	7981	9187	10939	11939	13861	16015
Water pressure drop user side	(4)	kPa	19	25	21	25	19	25
Water flow DHW side	(3)	l/h	9194	11061	12610	13717	15840	18435
Water pressure drop DHW side	(4)	kPa	25	34	27	32	24	32
Heating or DHW operation								
DHW heating capacity	(6)(E)	kW	53,0	63,8	72,7	79,1	91,3	106
Total power input	(6)(E)	kW	12,4	15,4	16,6	18,5	20,8	24,6
COP	(6)(E)		4,29	4,14	4,37	4,27	4,40	4,32
SCOP	(7)		4,16	4,30	4,38	4,31	4,36	4,21
Heating energy efficiency class	(8)		A+++					
Water flow DHW side	(6)	l/h	9194	11061	12610	13717	15840	18435
Water pressure drop DHW side	(6)	kPa	25	34	27	32	24	32
Water flow source side	(6)	l/h	11906	14225	16427	17784	20650	23965
Water pressure drop source side	(6)	kPa	39	54	44	51	39	51
General data								
Maximum current absorption		A	32,0	36,0	43,0	50,0	62,0	68,0
Start up current		A	117	140	161	143	171	208
Startup current with soft starter		A	60	68	81	91	111	126
Compressors / circuits			2 / 1					
Sound power level	(9)(E)	dB(A)	78	74	75	78	79	80
Sound power level, low-noise version	(9)	dB(A)	72	68	69	72	73	74
Transport / operating weight		kg	410	420	450	460	490	510

(1) Water temperature - user side 12°C / 7°C, water temperature - dissipation side 30°C / 35°C (EN14511:2022)

(2) η efficiency values for heating and cooling are respectively calculated by the following formulas: $[\eta = SCOP / 2,5 - F(1) - F(2)]$ e $[\eta = SEER / 2,5 - F(1) - F(2)]$. For further information, please refer to the technical document "ErP 2009/125/EC DIRECTIVE" in the catalogue introducing pages, or to the EN14825:2022 regulation.

(3) Cooling water temperature 7°C, water flow rate same as in cooling mode

(4) Recovery water temperature 45°C, water flow rate same as in cooling mode

(5) Cooling water temperature 7°C, recovery water temperature 45°C

(6) DHW water temperature 40°C / 45°C, water temperature - source side 10°C / 7°C (EN14511:2022)

(7) η efficiency values for heating and cooling are respectively calculated by the following formulas: $[\eta = SCOP / 2,5 - F(1) - F(2)]$ e $[\eta = SEER / 2,5 - F(1) - F(2)]$. For further information, please refer to the technical document "ErP 2009/125/EC DIRECTIVE" in the catalogue introducing pages, or to the EN14825:2022 regulation. Low temperature conditions.

(8) Seasonal energy efficiency class for MEDIUM TEMPERATURE room heating under AVERAGE climatic conditions [EUROPEAN REGULATION No 811/2013. The energy efficiency class of this product is included in the range A+++ → D]

(9) Sound power level measured according to ISO 9614

(E) EUROVENT certified data

RATED TECHNICAL DATA FOR 2-PIPES + DHW SYSTEMS

LEP M			112	132	142	144	162	164
Power supply		V-ph-Hz	400 - 3N - 50					
Cooling mode operation								
Cooling capacity	(1)(E)	kW	106	118	133	147	148	157
Total power input	(1)(E)	kW	24,3	27,1	30,6	34,5	34,4	36,7
EER	(1)(E)		4,36	4,33	4,36	4,26	4,30	4,27
SEER	(2)		6,40	6,38	6,31	6,07	6,17	6,19
Water flow user side	(1)	l/h	18206	20227	22925	25327	25442	26966
Water pressure drop user side	(1)(E)	kPa	31	38	35	41	38	33
Water flow source side	(1)	l/h	22186	24656	27932	30967	31063	32998
Water pressure drop source side	(1)(E)	kPa	45	54	49	60	54	48
Cooling mode operation and DHW in total recovery								
Cooling capacity	(3)(E)	kW	94,3	105	120	131	133	140
Heating capacity	(4)(E)	kW	124	138	157	173	174	184
Total power input	(5)(E)	kW	28,8	32,0	36,0	40,8	40,4	43,3
COP HRE	(5)(E)		7,57	7,61	7,68	7,46	7,60	7,50
Water flow user side	(3)	l/h	18206	20227	22925	25327	25442	26966
Water pressure drop user side	(4)	kPa	31	38	35	41	38	33
Water flow DHW side	(3)	l/h	20905	23287	26432	29364	29401	31244
Water pressure drop DHW side	(4)	kPa	40	49	45	54	49	43
Heating or DHW operation								
DHW heating capacity	(6)(E)	kW	121	134	152	169	170	180
Total power input	(6)(E)	kW	28,1	31,3	35,2	40,3	39,6	42,4
COP	(6)(E)		4,29	4,29	4,33	4,20	4,28	4,25
SCOP	(7)		4,29	4,24	4,29	4,34	4,28	4,28
Heating energy efficiency class	(8)		A+++					
Water flow DHW side	(6)	l/h	20905	23287	26432	29364	29401	31244
Water pressure drop DHW side	(6)	kPa	40	49	45	54	49	43
Water flow source side	(6)	l/h	27177	30319	34455	38020	38229	40474
Water pressure drop source side	(6)	kPa	64	78	72	86	79	69
General data								
Maximum current absorption		A	72,0	76,0	87,0	101	97,0	124
Start up current		A	212	279	289	222	336	233
Startup current with soft starter		A	133	141	161	131	180	147
Compressors / circuits			2 / 1	2 / 1	2 / 1	4 / 2	2 / 1	4 / 2
Sound power level	(9)(E)	dB(A)	84	86	86	78	86	82
Sound power level, low-noise version	(9)	dB(A)	78	80	80	72	80	76
Transport / operating weight		kg	690	700	770	1010	830	1050

- (1) Water temperature - user side 12°C / 7°C, water temperature - dissipation side 30°C / 35°C (EN14511:2022)
- (2) η efficiency values for heating and cooling are respectively calculated by the following formulas: $[\eta = SCOP / 2,5 - F(1) - F(2)]$ e $[\eta = SEER / 2,5 - F(1) - F(2)]$. For further information, please refer to the technical document "ErP 2009/125/EC DIRECTIVE" in the catalogue introducing pages, or to the EN14825:2022 regulation.
- (3) Cooling water temperature 7°C, water flow rate same as in cooling mode
- (4) Recovery water temperature 45°C, water flow rate same as in cooling mode
- (5) Cooling water temperature 7°C, recovery water temperature 45°C
- (6) DHW water temperature 40°C / 45°C, water temperature - source side 10°C / 7°C (EN14511:2022)
- (7) η efficiency values for heating and cooling are respectively calculated by the following formulas: $[\eta = SCOP / 2,5 - F(1) - F(2)]$ e $[\eta = SEER / 2,5 - F(1) - F(2)]$. For further information, please refer to the technical document "ErP 2009/125/EC DIRECTIVE" in the catalogue introducing pages, or to the EN14825:2022 regulation. Low temperature conditions.
- (8) Seasonal energy efficiency class for MEDIUM TEMPERATURE room heating under AVERAGE climatic conditions [EUROPEAN REGULATION No 811/2013. The energy efficiency class of this product is included in the range A+++ → D]
- (9) Sound power level measured according to ISO 9614
- (E) EUROVENT certified data

Total heat recovery multi-purpose units LEP

RATED TECHNICAL DATA FOR 2-PIPES + DHW SYSTEMS

LEP M			182	184	204	214	244
Power supply		V-ph-Hz	400 - 3N - 50				
Cooling mode operation							
Cooling capacity	(1)(E)	kW	196	186	211	235	255
Total power input	(1)(E)	kW	44,8	42,9	48,3	54,1	56,2
EER	(1)(E)		4,38	4,34	4,37	4,35	4,53
SEER	(2)		6,37	6,47	6,43	6,54	6,87
Water flow user side	(1)	l/h	33780	32039	36308	40457	43793
Water pressure drop user side	(1)(E)	kPa	34	31	39	47	27
Water flow source side	(1)	l/h	41172	39112	44245	49307	53152
Water pressure drop source side	(1)(E)	kPa	49	45	56	68	35
Cooling mode operation and DHW in total recovery							
Cooling capacity	(3)(E)	kW	176	167	189	211	229
Heating capacity	(4)(E)	kW	230	219	247	276	297
Total power input	(5)(E)	kW	52,6	50,2	56,8	63,6	66,5
COP HRE	(5)(E)		7,71	7,68	7,68	7,66	7,91
Water flow user side	(3)	l/h	33780	32039	36308	40457	43793
Water pressure drop user side	(4)	kPa	34	31	39	47	27
Water flow DHW side	(3)	l/h	38731	36908	41796	46601	50165
Water pressure drop DHW side	(4)	kPa	44	40	50	61	35
Heating or DHW operation							
DHW heating capacity	(6)(E)	kW	223	213	241	269	289
Total power input	(6)(E)	kW	51,3	49,0	55,7	62,6	64,8
COP	(6)(E)		4,35	4,34	4,32	4,29	4,46
SCOP	(7)		4,34	4,37	4,31	4,34	4,43
Heating energy efficiency class	(8)		A+++				
Water flow DHW side	(6)	l/h	38731	36908	41796	46601	50165
Water pressure drop DHW side	(6)	kPa	44	40	50	61	35
Water flow source side	(6)	l/h	50490	48044	54439	60721	65630
Water pressure drop source side	(6)	kPa	71	65	81	99	51
General data							
Maximum current absorption		A	131	136	144	153	163
Start up current		A	375	276	284	355	366
Startup current with soft starter		A	240	175	185	195	208
Compressors / circuits			2 / 1	4 / 2	4 / 2	4 / 2	4 / 2
Sound power level	(9)(E)	dB(A)	88	83	87	89	89
Sound power level, low-noise version	(9)	dB(A)	82	77	81	83	83
Transport / operating weight		kg	890	1130	1280	1350	1840

(1) Water temperature - user side 12°C / 7°C, water temperature - dissipation side 30°C / 35°C (EN14511:2022)

(2) η efficiency values for heating and cooling are respectively calculated by the following formulas: $[\eta = SCOP / 2,5 - F(1) - F(2)]$ e $[\eta = SEER / 2,5 - F(1) - F(2)]$. For further information, please refer to the technical document "ErP 2009/125/EC DIRECTIVE" in the catalogue introducing pages, or to the EN14825:2022 regulation.

(3) Cooling water temperature 7°C, water flow rate same as in cooling mode

(4) Recovery water temperature 45°C, water flow rate same as in cooling mode

(5) Cooling water temperature 7°C, recovery water temperature 45°C

(6) DHW water temperature 40°C / 45°C, water temperature - source side 10°C / 7°C (EN14511:2022)

(7) η efficiency values for heating and cooling are respectively calculated by the following formulas: $[\eta = SCOP / 2,5 - F(1) - F(2)]$ e $[\eta = SEER / 2,5 - F(1) - F(2)]$. For further information, please refer to the technical document "ErP 2009/125/EC DIRECTIVE" in the catalogue introducing pages, or to the EN14825:2022 regulation. Low temperature conditions.

(8) Seasonal energy efficiency class for MEDIUM TEMPERATURE room heating under AVERAGE climatic conditions [EUROPEAN REGULATION No 811/2013. The energy efficiency class of this product is included in the range A+++ → D]

(9) Sound power level measured according to ISO 9614

(E) EUROVENT certified data

RATED TECHNICAL DATA FOR 2-PIPES + DHW SYSTEMS

LEP M			284	314	344	374	424
Power supply		V-ph-Hz	400 - 3N - 50				
Cooling mode operation							
Cooling capacity	(1)(E)	kW	268	293	342	391	444
Total power input	(1)(E)	kW	60,2	68,3	78,7	89,6	102
EER	(1)(E)		4,45	4,29	4,35	4,36	4,34
SEER	(2)		6,67	6,31	6,40	6,47	6,77
Water flow user side	(1)	l/h	46045	50342	58850	67166	76360
Water pressure drop user side	(1)(E)	kPa	30	35	33	33	36
Water flow source side	(1)	l/h	56037	61627	71915	82041	93312
Water pressure drop source side	(1)(E)	kPa	40	48	45	47	52
Cooling mode operation and DHW in total recovery							
Cooling capacity	(3)(E)	kW	241	264	307	350	399
Heating capacity	(4)(E)	kW	314	346	402	457	521
Total power input	(5)(E)	kW	71,0	80,2	92,4	105	119
COP HRE	(5)(E)		7,82	7,60	7,68	7,69	7,71
Water flow user side	(3)	l/h	46045	50342	58850	67166	76360
Water pressure drop user side	(4)	kPa	30	35	33	33	36
Water flow DHW side	(3)	l/h	52937	58369	67838	77045	87830
Water pressure drop DHW side	(4)	kPa	38	46	42	43	47
Heating or DHW operation							
DHW heating capacity	(6)(E)	kW	305	336	391	444	506
Total power input	(6)(E)	kW	69,3	78,2	90,0	102	116
COP	(6)(E)		4,40	4,30	4,34	4,34	4,35
SCOP	(7)		4,37	4,29	4,34	4,34	4,20
Heating energy efficiency class	(8)		A+++				
Water flow DHW side	(6)	l/h	52937	58369	67838	77045	87830
Water pressure drop DHW side	(6)	kPa	38	46	42	43	47
Water flow source side	(6)	l/h	69045	75765	88200	100174	114375
Water pressure drop source side	(6)	kPa	58	70	65	67	75
General data							
Maximum current absorption		A	174	194	228	262	296
Start up current		A	376	433	467	506	541
Startup current with soft starter		A	221	247	287	328	370
Compressors / circuits			4 / 2	4 / 2	4 / 2	4 / 2	4 / 2
Sound power level	(9)(E)	dB(A)	89	89	90	91	94
Sound power level, low-noise version	(9)	dB(A)	83	83	84	85	88
Transport / operating weight		kg	1940	2040	2110	2180	2380

- (1) Water temperature - user side 12°C / 7°C, water temperature - dissipation side 30°C / 35°C (EN14511:2022)
 - (2) η efficiency values for heating and cooling are respectively calculated by the following formulas: $[\eta = SCOP / 2,5 - F(1) - F(2)]$ e $[\eta = SEER / 2,5 - F(1) - F(2)]$. For further information, please refer to the technical document "ErP 2009/125/EC DIRECTIVE" in the catalogue introducing pages, or to the EN14825:2022 regulation.
 - (3) Cooling water temperature 7°C, water flow rate same as in cooling mode
 - (4) Recovery water temperature 45°C, water flow rate same as in cooling mode
 - (5) Cooling water temperature 7°C, recovery water temperature 45°C
 - (6) DHW water temperature 40°C / 45°C, water temperature - source side 10°C / 7°C (EN14511:2022)
 - (7) η efficiency values for heating and cooling are respectively calculated by the following formulas: $[\eta = SCOP / 2,5 - F(1) - F(2)]$ e $[\eta = SEER / 2,5 - F(1) - F(2)]$. For further information, please refer to the technical document "ErP 2009/125/EC DIRECTIVE" in the catalogue introducing pages, or to the EN14825:2022 regulation. Low temperature conditions.
 - (8) Seasonal energy efficiency class for MEDIUM TEMPERATURE room heating under AVERAGE climatic conditions [EUROPEAN REGULATION No 811/2013. The energy efficiency class of this product is included in the range A+++ → D]
 - (9) Sound power level measured according to ISO 9614
- (E) EUROVENT certified data

Total heat recovery multi-purpose units LEP

RATED TECHNICAL DATA FOR 4-PIPES SYSTEMS

LEP P			042	052	062	072	082	092
Power supply		V-ph-Hz	400 - 3N - 50					
Cooling mode operation								
Cooling capacity	(1)(E)	kW	45,1	52,1	61,7	67,2	78,1	90,0
Total power input	(1)(E)	kW	10,8	12,8	14,7	16,3	18,4	22,2
EER	(1)(E)		4,16	4,08	4,19	4,12	4,25	4,06
SEER	(2)		5,61	5,52	5,87	5,81	6,17	6,12
Water flow user side	(1)	l/h	7762	8971	10625	11569	13439	15495
Water pressure drop user side	(1)(E)	kPa	29	38	41	37	29	39
Water flow source side	(1)	l/h	9542	11046	13031	14225	16462	19100
Water pressure drop source side	(1)(E)	kPa	41	54	44	53	41	55
Cooling and heating mode in total heat recovery								
Cooling capacity	(3)(E)	kW	40,2	46,5	55,1	59,8	69,7	80,5
Heating capacity	(4)(E)	kW	53,4	62,1	73,2	79,7	92,0	107
Total power input	(5)(E)	kW	12,9	15,1	17,5	19,4	21,7	25,8
COP HRE	(5)(E)		7,25	7,19	7,33	7,19	7,44	7,27
Water flow cooling side	(3)	l/h	7762	8971	10625	11569	13439	15495
Water pressure cooling heating side	(4)	kPa	29	38	41	37	29	39
Water flow heating side	(3)	l/h	9238	10721	12635	13772	15896	18483
Water pressure drop heating side	(4)	kPa	39	51	41	50	39	52
Heating mode operation								
Heating capacity	(6)(E)	kW	53,3	61,9	72,9	79,5	91,7	107
Total power input	(6)(E)	kW	13,0	15,2	17,6	19,5	21,8	25,8
COP	(6)(E)		4,11	4,08	4,15	4,08	4,21	4,13
SCOP	(7)		4,16	4,30	4,38	4,31	4,36	4,21
Heating energy efficiency class	(8)		A+++					
Water flow user side	(6)	l/h	9238	10721	12635	13772	15896	18483
Water pressure drop user side	(6)	kPa	39	51	41	50	39	52
Water flow source side	(6)	l/h	11881	13816	16341	17714	20565	23832
Water pressure drop source side	(6)	kPa	63	83	88	79	62	84
General data								
Maximum current absorption		A	32,0	36,0	43,0	50,0	62,0	68,0
Start up current		A	117	140	161	143	171	208
Startup current with soft starter		A	60	68	81	91	111	126
Compressors / circuits			2 / 1					
Sound power level	(9)(E)	dB(A)	78	74	75	78	79	80
Sound power level, low-noise version	(9)	dB(A)	72	68	69	72	73	74
Transport / operating weight		kg	410	420	450	460	490	510

(1) Water temperature - user side 12°C / 7°C, water temperature - dissipation side 30°C / 35°C (EN14511:2022)

(2) η efficiency values for heating and cooling are respectively calculated by the following formulas: $[\eta = SCOP / 2,5 - F(1) - F(2)]$ e $[\eta = SEER / 2,5 - F(1) - F(2)]$. For further information, please refer to the technical document "ErP 2009/125/EC DIRECTIVE" in the catalogue introducing pages, or to the EN14825:2022 regulation.

(3) Cooling water temperature 7°C, water flow rate same as in cooling mode

(4) Recovery water temperature 45°C, water flow rate same as in cooling mode

(5) Cooling water temperature 7°C, recovery water temperature 45°C

(6) User side water temperature 40°C / 45°C, water temperature - source side 10°C / 7°C (EN14511:2022)

(7) η efficiency values for heating and cooling are respectively calculated by the following formulas: $[\eta = SCOP / 2,5 - F(1) - F(2)]$ e $[\eta = SEER / 2,5 - F(1) - F(2)]$. For further information, please refer to the technical document "ErP 2009/125/EC DIRECTIVE" in the catalogue introducing pages, or to the EN14825:2022 regulation. Low temperature conditions.

(8) Seasonal energy efficiency class for MEDIUM TEMPERATURE room heating under AVERAGE climatic conditions [EUROPEAN REGULATION No 811/2013. The energy efficiency class of this product is included in the range A+++ → D]

(9) Sound power level measured according to ISO 9614

(E) EUROVENT certified data

RATED TECHNICAL DATA FOR 4-PIPES SYSTEMS

LEP P			112	132	142	144	162	164
Power supply		V-ph-Hz	400 - 3N - 50					
Cooling mode operation								
Cooling capacity	(1)(E)	kW	105	118	133	147	148	154
Total power input	(1)(E)	kW	24,3	27,1	30,5	34,6	34,4	37,2
EER	(1)(E)		4,32	4,34	4,37	4,25	4,30	4,14
SEER	(2)		6,40	6,38	6,31	6,07	6,17	6,19
Water flow user side	(1)	l/h	18052	20226	22925	25326	25442	26513
Water pressure drop user side	(1)(E)	kPa	32	37	34	41	38	40
Water flow source side	(1)	l/h	22042	24649	27925	30973	31068	32601
Water pressure drop source side	(1)(E)	kPa	43	52	47	57	51	57
Cooling and heating mode in total heat recovery								
Cooling capacity	(5)(E)	kW	94,3	105	120	131	133	138
Heating capacity	(6)(E)	kW	125	138	157	173	174	183
Total power input	(7)(E)	kW	29,0	32,0	36,0	40,8	40,4	43,7
COP HRE	(7)(E)		7,56	7,61	7,68	7,46	7,60	7,33
Water flow cooling side	(3)	l/h	18052	20226	22925	25326	25442	26513
Water pressure cooling heating side	(4)	kPa	32	37	34	41	38	40
Water flow heating side	(3)	l/h	21633	23861	27058	29886	30096	31588
Water pressure drop heating side	(4)	kPa	41	49	45	53	49	53
Heating mode operation								
Heating capacity	(6)(E)	kW	125	138	156	172	174	182
Total power input	(6)(E)	kW	29,1	32,1	36,0	41,0	40,4	43,9
COP	(6)(E)		4,29	4,29	4,33	4,20	4,29	4,15
SCOP	(7)		4,29	4,24	4,29	4,34	4,28	4,28
Heating energy efficiency class	(8)		A+++					
Water flow user side	(6)	l/h	21633	23861	27058	29886	30096	31588
Water pressure drop user side	(6)	kPa	41	49	45	53	49	53
Water flow source side	(6)	l/h	28118	31073	35278	38699	39167	40747
Water pressure drop source side	(6)	kPa	70	81	75	88	82	87
General data								
Maximum current absorption		A	72,0	76,0	87,0	101	97,0	124
Start up current		A	212	279	289	222	336	233
Startup current with soft starter		A	133	141	161	131	180	147
Compressors / circuits			2 / 1	2 / 1	2 / 1	4 / 2	2 / 1	4 / 2
Sound power level	(9)(E)	dB(A)	84	86	86	78	86	82
Sound power level, low-noise version	(9)	dB(A)	78	80	80	72	80	76
Transport / operating weight		kg	690	700	770	1010	830	1050

- (1) Water temperature - user side 12°C / 7°C, water temperature - dissipation side 30°C / 35°C (EN14511:2022)
- (2) η efficiency values for heating and cooling are respectively calculated by the following formulas: $[\eta = SCOP / 2,5 - F(1) - F(2)]$ e $[\eta = SEER / 2,5 - F(1) - F(2)]$. For further information, please refer to the technical document "ErP 2009/125/EC DIRECTIVE" in the catalogue introducing pages, or to the EN14825:2022 regulation.
- (3) Cooling water temperature 7°C, water flow rate same as in cooling mode
- (4) Recovery water temperature 45°C, water flow rate same as in cooling mode
- (5) Cooling water temperature 7°C, recovery water temperature 45°C
- (6) User side water temperature 40°C / 45°C, water temperature - source side 10°C / 7°C (EN14511:2022)
- (7) η efficiency values for heating and cooling are respectively calculated by the following formulas: $[\eta = SCOP / 2,5 - F(1) - F(2)]$ e $[\eta = SEER / 2,5 - F(1) - F(2)]$. For further information, please refer to the technical document "ErP 2009/125/EC DIRECTIVE" in the catalogue introducing pages, or to the EN14825:2022 regulation. Low temperature conditions.
- (8) Seasonal energy efficiency class for MEDIUM TEMPERATURE room heating under AVERAGE climatic conditions [EUROPEAN REGULATION No 811/2013. The energy efficiency class of this product is included in the range A+++ → D]
- (9) Sound power level measured according to ISO 9614
- (E) EUROVENT certified data

Total heat recovery multi-purpose units LEP

RATED TECHNICAL DATA FOR 4-PIPES SYSTEMS

LEP P			182	184	204	214	244
Power supply		V-ph-Hz	400 - 3N - 50				
Cooling mode operation							
Cooling capacity	(1)(E)	kW	193	184	208	235	255
Total power input	(1)(E)	kW	45,4	43,3	49,1	54,0	56,2
EER	(1)(E)		4,26	4,25	4,24	4,36	4,53
SEER	(2)		6,37	6,47	6,43	6,54	6,87
Water flow user side	(1)	l/h	33250	31616	35778	40456	43793
Water pressure drop user side	(1)(E)	kPa	39	37	45	46	27
Water flow source side	(1)	l/h	40701	38732	43800	49301	53152
Water pressure drop source side	(1)(E)	kPa	55	51	64	64	35
Cooling and heating mode in total heat recovery							
Cooling capacity	(5)(E)	kW	173	165	186	211	229
Heating capacity	(6)(E)	kW	228	217	245	276	297
Total power input	(7)(E)	kW	53,1	50,7	57,5	63,6	66,5
COP HRE	(7)(E)		7,55	7,52	7,51	7,66	7,91
Water flow cooling side	(3)	l/h	33250	31616	35778	40456	43793
Water pressure cooling heating side	(4)	kPa	39	37	45	46	27
Water flow heating side	(3)	l/h	39278	37444	42416	47748	51400
Water pressure drop heating side	(4)	kPa	51	48	60	61	33
Heating mode operation							
Heating capacity	(6)(E)	kW	226	216	244	275	296
Total power input	(6)(E)	kW	53,1	50,8	57,8	64,0	66,5
COP	(6)(E)		4,26	4,25	4,23	4,30	4,45
SCOP	(7)		4,34	4,37	4,31	4,34	4,43
Heating energy efficiency class	(8)		A+++				
Water flow user side	(6)	l/h	39278	37444	42416	47748	51400
Water pressure drop user side	(6)	kPa	51	48	60	61	33
Water flow source side	(6)	l/h	50988	48551	55050	62254	67248
Water pressure drop source side	(6)	kPa	85	79	98	99	59
General data							
Maximum current absorption		A	131	136	144	153	163
Start up current		A	375	276	284	355	366
Startup current with soft starter		A	240	175	185	195	208
Compressors / circuits			2 / 1	4 / 2	4 / 2	4 / 2	4 / 2
Sound power level	(9)(E)	dB(A)	88	83	87	89	89
Sound power level, low-noise version	(9)	dB(A)	82	77	81	83	83
Transport / operating weight		kg	890	1130	1280	1350	1840

(1) Water temperature - user side 12°C / 7°C, water temperature - dissipation side 30°C / 35°C (EN14511:2022)

(2) η efficiency values for heating and cooling are respectively calculated by the following formulas: $[\eta = SCOP / 2,5 - F(1) - F(2)]$ e $[\eta = SEER / 2,5 - F(1) - F(2)]$. For further information, please refer to the technical document "ErP 2009/125/EC DIRECTIVE" in the catalogue introducing pages, or to the EN14825:2022 regulation.

(3) Cooling water temperature 7°C, water flow rate same as in cooling mode

(4) Recovery water temperature 45°C, water flow rate same as in cooling mode

(5) Cooling water temperature 7°C, recovery water temperature 45°C

(6) User side water temperature 40°C / 45°C, water temperature - source side 10°C / 7°C (EN14511:2022)

(7) η efficiency values for heating and cooling are respectively calculated by the following formulas: $[\eta = SCOP / 2,5 - F(1) - F(2)]$ e $[\eta = SEER / 2,5 - F(1) - F(2)]$. For further information, please refer to the technical document "ErP 2009/125/EC DIRECTIVE" in the catalogue introducing pages, or to the EN14825:2022 regulation. Low temperature conditions.

(8) Seasonal energy efficiency class for MEDIUM TEMPERATURE room heating under AVERAGE climatic conditions [EUROPEAN REGULATION No 811/2013. The energy efficiency class of this product is included in the range A+++ → D]

(9) Sound power level measured according to ISO 9614

(E) EUROVENT certified data

RATED TECHNICAL DATA FOR 4-PIPES SYSTEMS

LEP P			284	314	344	374	424
Power supply		V-ph-Hz	400 - 3N - 50				
Cooling mode operation							
Cooling capacity	(1)(E)	kW	268	293	337	381	436
Total power input	(1)(E)	kW	60,2	68,3	79,5	90,9	103
EER	(1)(E)		4,45	4,29	4,24	4,19	4,21
SEER	(2)		6,67	6,31	6,40	4,47	6,77
Water flow user side	(1)	l/h	46045	50342	57960	65436	74851
Water pressure drop user side	(1)(E)	kPa	30	35	37	40	41
Water flow source side	(1)	l/h	56037	61627	71109	80440	91927
Water pressure drop source side	(1)(E)	kPa	40	48	51	55	57
Cooling and heating mode in total heat recovery							
Cooling capacity	(5)(E)	kW	241	264	303	342	392
Heating capacity	(6)(E)	kW	314	346	398	450	515
Total power input	(7)(E)	kW	71,0	80,2	93,0	106	120
COP HRE	(7)(E)		7,82	7,60	7,54	7,47	7,55
Water flow cooling side	(3)	l/h	46045	50342	57960	65436	74851
Water pressure cooling heating side	(4)	kPa	30	35	37	40	41
Water flow heating side	(3)	l/h	54223	59828	68859	77890	89023
Water pressure drop heating side	(4)	kPa	38	46	49	52	54
Heating mode operation							
Heating capacity	(6)(E)	kW	312	345	397	449	513
Total power input	(6)(E)	kW	71,0	80,1	93,3	106	121
COP	(6)(E)		4,40	4,30	4,25	4,22	4,25
SCOP	(7)		4,37	4,29	4,34	4,34	4,20
Heating energy efficiency class	(8)		A+++				
Water flow user side	(6)	l/h	54223	59828	68859	77890	89023
Water pressure drop user side	(6)	kPa	38	46	49	52	54
Water flow source side	(6)	l/h	70760	77706	89182	100719	115372
Water pressure drop source side	(6)	kPa	64	76	81	86	89
General data							
Maximum current absorption		A	174	194	228	262	296
Start up current		A	376	433	467	506	541
Startup current with soft starter		A	221	247	287	328	370
Compressors / circuits			4 / 2	4 / 2	4 / 2	4 / 2	4 / 2
Sound power level	(9)(E)	dB(A)	89	89	90	91	94
Sound power level, low-noise version	(9)	dB(A)	83	83	84	85	88
Transport / operating weight		kg	1940	2040	2110	2180	2380

- (1) Water temperature - user side 12°C / 7°C, water temperature - dissipation side 30°C / 35°C (EN14511:2022)
- (2) η efficiency values for heating and cooling are respectively calculated by the following formulas: $[\eta = SCOP / 2,5 - F(1) - F(2)]$ e $[\eta = SEER / 2,5 - F(1) - F(2)]$. For further information, please refer to the technical document "ErP 2009/125/EC DIRECTIVE" in the catalogue introducing pages, or to the EN14825:2022 regulation.
- (3) Cooling water temperature 7°C, water flow rate same as in cooling mode
- (4) Recovery water temperature 45°C, water flow rate same as in cooling mode
- (5) Cooling water temperature 7°C, recovery water temperature 45°C
- (6) User side water temperature 40°C / 45°C, water temperature - source side 10°C / 7°C (EN14511:2022)
- (7) η efficiency values for heating and cooling are respectively calculated by the following formulas: $[\eta = SCOP / 2,5 - F(1) - F(2)]$ e $[\eta = SEER / 2,5 - F(1) - F(2)]$. For further information, please refer to the technical document "ErP 2009/125/EC DIRECTIVE" in the catalogue introducing pages, or to the EN14825:2022 regulation. Low temperature conditions.
- (8) Seasonal energy efficiency class for MEDIUM TEMPERATURE room heating under AVERAGE climatic conditions [EUROPEAN REGULATION No 811/2013. The energy efficiency class of this product is included in the range A+++ → D]
- (9) Sound power level measured according to ISO 9614
- (E) EUROVENT certified data

Total heat recovery multi-purpose units LEP

DIMENSIONAL DRAWINGS

LEP 041 - 092

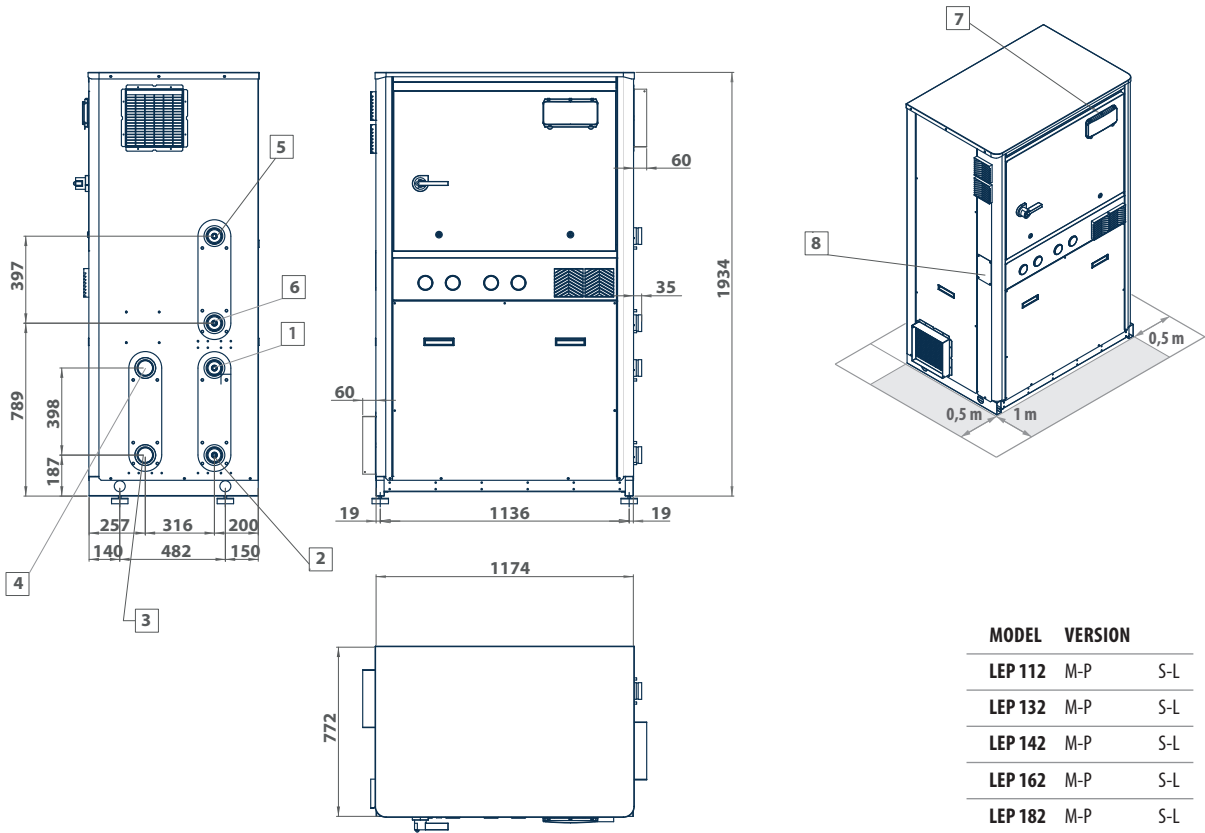

LEP 112 - 182

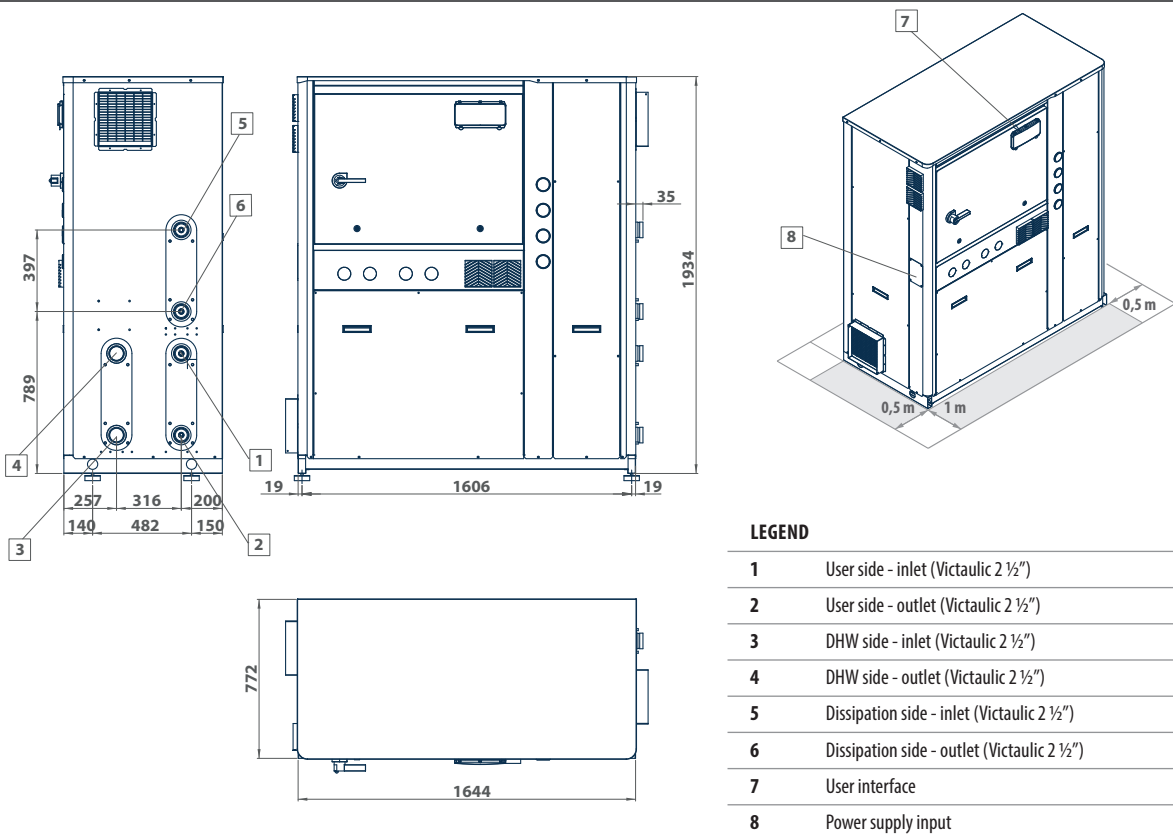

DIMENSIONAL DRAWINGS

LEP 144 - 184

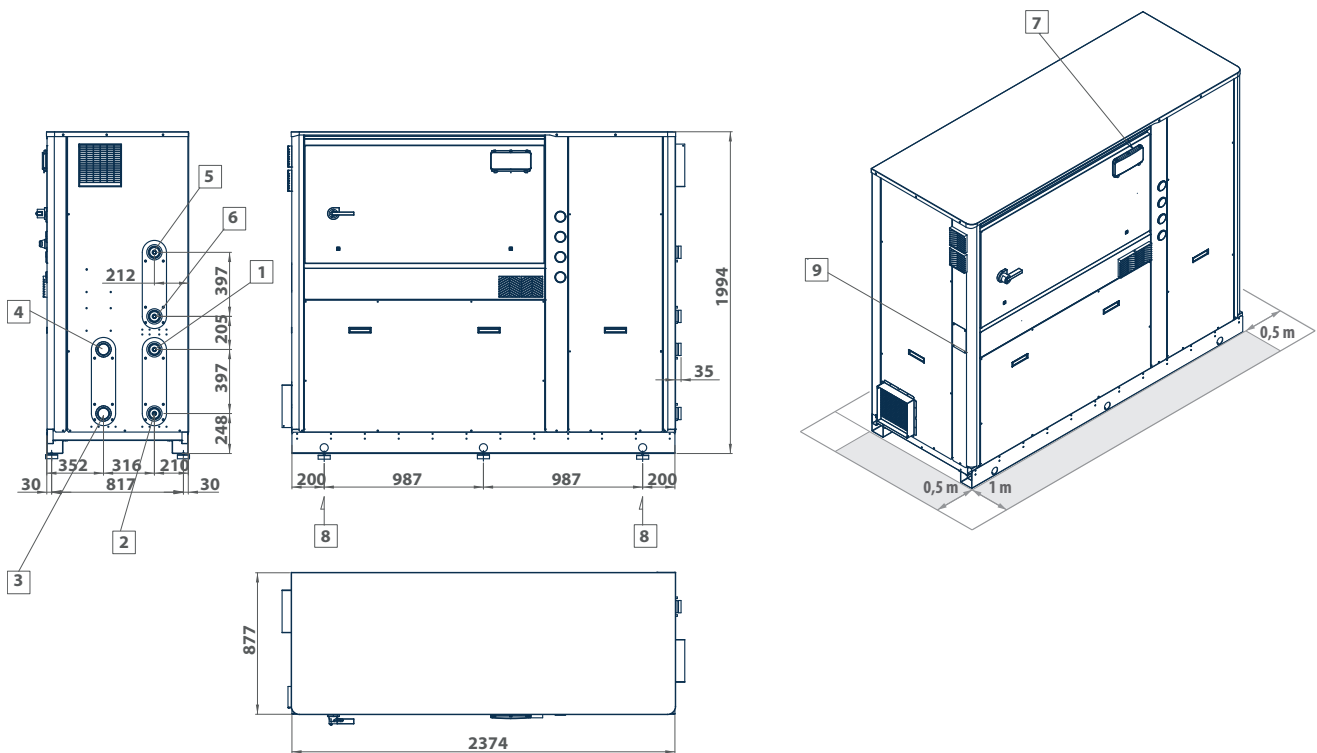

LEGEND

1	User side - inlet (Victaulic 2 ½")
2	User side - outlet (Victaulic 2 ½")
3	DHW side - inlet (Victaulic 2 ½")
4	DHW side - outlet (Victaulic 2 ½")
5	Dissipation side - inlet (Victaulic 2 ½")
6	Dissipation side - outlet (Victaulic 2 ½")
7	User interface
8	Lifting points
9	Power supply input

MODEL VERSION

LEP 144	M-P	S-L
LEP 164	M-P	S-L
LEP 184	M-P	S-L

Total heat recovery multi-purpose units - LEP

Total heat recovery multi-purpose units LEP

DIMENSIONAL DRAWINGS

LEP 204 - 214

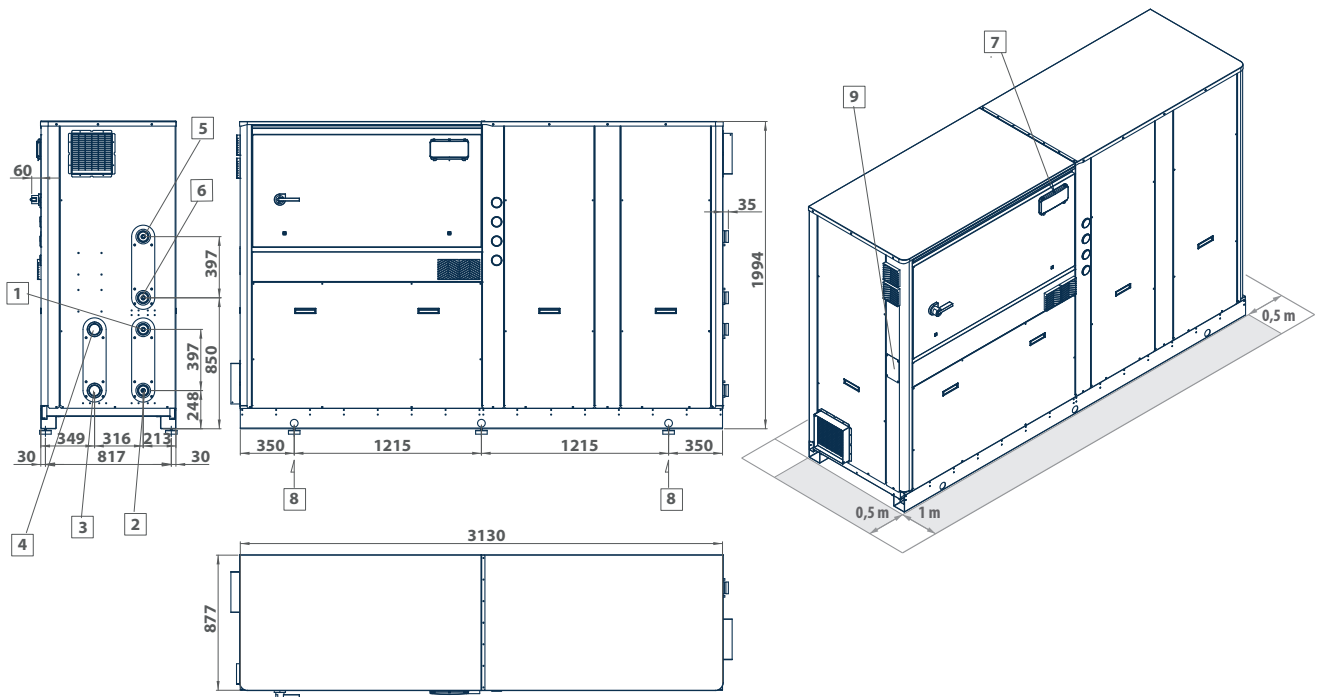

LEGEND

1	User side - inlet (Victaulic 2 ½")
2	User side - outlet (Victaulic 2 ½")
3	DHW side - inlet (Victaulic 2 ½")
4	DHW side - outlet (Victaulic 2 ½")
5	Dissipation side - inlet (Victaulic 2 ½")
6	Dissipation side - outlet (Victaulic 2 ½")
7	User interface
8	Lifting points
9	Power supply input

MODEL VERSION

LEP 204	M-P	S-L
LEP 214	M-P	S-L

DIMENSIONAL DRAWINGS

LEP 244 - 424

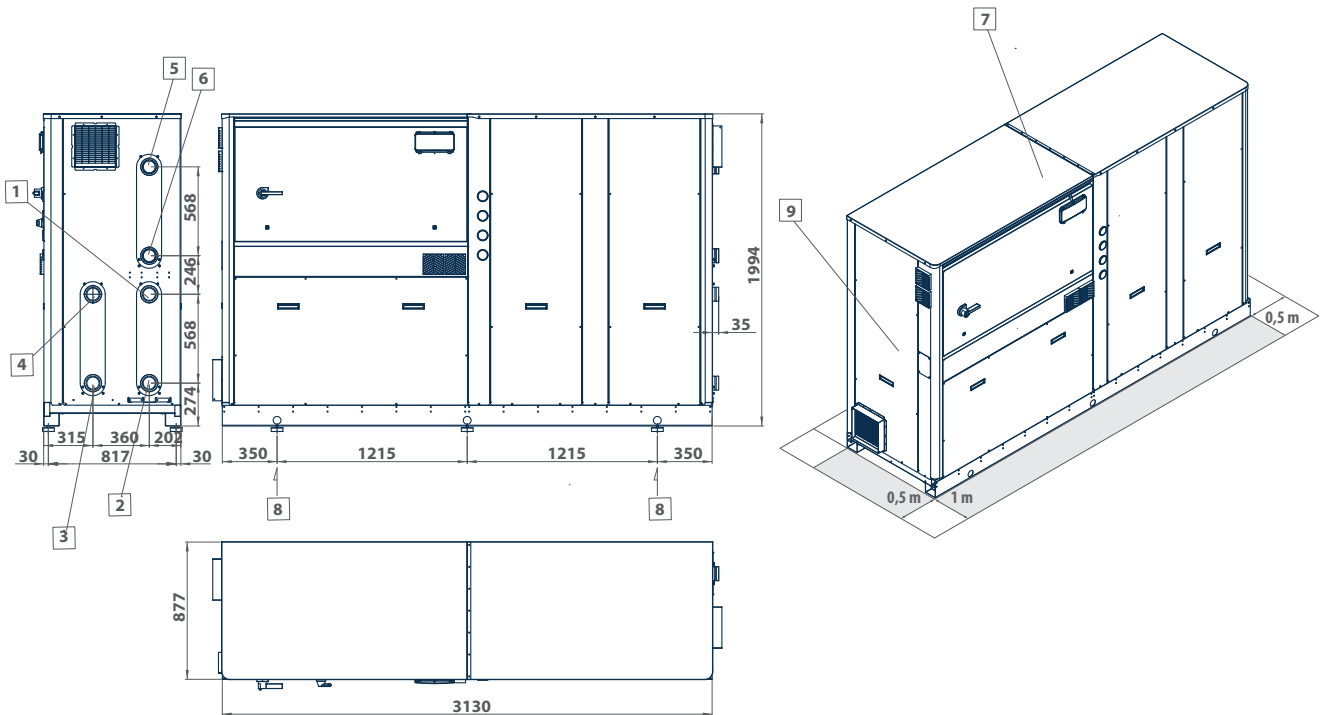

LEGEND

1	User side - inlet (Victaulic 3")
2	User side - outlet (Victaulic 3")
3	DHW side - inlet (Victaulic 3")
4	DHW side - outlet (Victaulic 3")
5	Dissipation side - inlet (Victaulic 3")
6	Dissipation side - outlet (Victaulic 3")
7	User interface
8	Lifting points
9	Power supply input

MODEL	VERSION	
LEP 244	M-P	S-L
LEP 284	M-P	S-L
LEP 314	M-P	S-L
LEP 344	M-P	S-L
LEP 374	M-P	S-L
LEP 424	M-P	S-L

Total heat recovery multi-purpose units - LEP



HEAT RECOVERY UNIT AND THERMOVENTILATING

Introduction p.386

RPE p.388



COMPANY

EXPERIENCE AND FLEXIBILITY IN AIR TREATMENT FOR CIVIL AND INDUSTRIAL AIR CONDITIONING.

Cetra was founded at the end of the '70s in a small 300 sqm. warehouse where, thanks to skill acquired from previous experience in the air conditioning sector, the first thermo-ventilating units (TVU) were manufactured for the local market.

In the mid '80s one of the founders patented the technical solution that everyone in the sector knows today as the 3-way joint, the pivotal development that made it possible to build modular TVUs from that point on. At the same time they began to develop their first relationships with the major companies in the sector (Carrier, Marelli), making it possible, over the following decades, for the company to establish itself in Italy as one of the standard-setting businesses in the air treatment sector, and to expand into the international market.

Becoming part of Galletti group boosted the company's growth, thanks to beneficial synergies with other companies in the Group, creating cross-competences and technological solutions. Throughout this significant evolution, Cetra has maintained the typical values of a family-run business, where work is considered a trade, and is therefore a guarantee for excellent quality. Today, within Galletti Group, Cetra is the leader of the air treatment market for the residential and tertiary sectors, with a complete range of Eurovent-certified products. The air treatment facilities can be set so that the customer has the option of integrating them with any of the Galletti Group products. The company has developed relevant technical skills in specific sectors, such as pharmaceutical, hospital and food.

The Cetra production facility in Altedo (BO) houses a sheet metal processing division, an extensive production line divided into 6 different areas, each one dedicated to a specific sector, and a complete testing line for all of the units.

Following the Galletti Group philosophy of managing all of the production process phases in-house, today Cetra is known on the market as one of the most flexible and dynamic companies in the air treatment industry. It is known for being able to fulfil the specific requests of its stakeholders, confirmed by the addition of the rooftop air-to-air monobloc independent air conditioner in the Cetra product catalogue.

HEAT RECOVERY UNIT

RPE S

9 models
2 configurations
Cross flow heat exchanger
By pass free cooling
EC motor
Efficiency 90%

Air flow:
from 500 to 6000 mc/h



RPE X

9 models
2 configurations
Cross flow heat exchanger
By pass free cooling
EC motor
Efficiency 90%

Air flow:
from 500 to 6000 mc/h

THERMOVENTILATING

TH

9 models
2 or 4 pipes system
EC plug-fans
Air flow:
from 750 to 28000 mc/h
Cooling capacity:
from 6 to 300 kW



TV

9 models
2 or 4 pipes system
EC plug-fans
Air flow:
from 750 to 28000 mc/h
Cooling capacity:
from 6 to 300 kW



EXTRACTORS

TCE/TCX(Atex)

5 models
EC fans
AESP up to 600 pa
Air flow:
from 800 to 8000 mc/h (TCE)
from 9000 to 16500 mc/h (TCX)



AHU

CT

39 models
Completely customized
Indoor or outdoor installation
Air flow:
from 1000 to 100000 mc/h



ADJUSTABLE AHU

CTR

39 models
Complete with regulation
Completely customized
Indoor or outdoor installation
Air flow:
from 1000 to 100000 mc/h



UTX EUROVENT

UTX

39 models
Eurovent certification
Completely customized
Installation indoor or outdoor
Air flow:
from 1000 to 100000 mc/h



AHU POOL APPLICATION

CTP

39 models
Pre-painted component
Chlorine resistant
Completely customized
Indoor or outdoor installation
Air flow:
from 1000 to 100000 mc/h

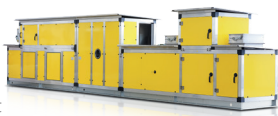

CTA HOSPITAL APPLICATION

CTH

39 models
Component AISI 316
Sanification unit
Completely customized
Indoor or outdoor installation
Air flow:
from 1000 to 100000 mc/h

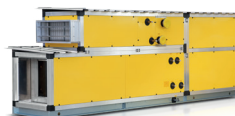

AHU FOOD APPLICATION

CTF

39 models
Component AISI 316
Mineral wool insulation
Completely customized
Indoor or outdoor insulation
Air flow:
from 1000 to 100000 mc/h



Mechanical ventilation units with heat recovery

RPE 500 - 6000 mc/h



Brushless motor



Ducted

PLUS

- » Air flow up to 6.000 m³/h
- » Horizontal/vertical configuration
- » Plug-fan with integrated inverter
- » Internal electric board
- » Inspection and maintenance possible from the side (for all models) and also from the bottom (for horizontal models)
- » Easy maintenance
- » Double outlet filtration (F7 + F9) (ACCESSORY)
- » Automatic Free cooling, with bypass actuator (ACCESSORY)
- » Combined with hydronic or direct expansion units (ACCESSORY)
- » Jonix sanitizing module (ACCESSORY)

Static upstream-flow heat recovery unit, made of aluminum, with high efficiency (90%)

The units of the RPE series for air recirculation and heat recovery, available in 2 versions (RPE-S and RPE-X) and 9 models are characterized by closing panels made of a double sheet of galvanized steel, pre-painted on the outer surface, completely removable for inspection/maintenance, and with different inlet/outlet configurations.

Internal heat and sound insulation made from polyurethane foam or mineral wool with a thickness of 30 mm. Ventilation sections with directly coupled electric fans with motor BLDC.

Upstream-flow heat recovery, with aluminium heat exchanger sealed at the ends in order to prevent contamination of the fresh air.

Bypass damper inserted inside the unit controlled by the EVO control system (ACCESSORY). F7 filter on the outlet (F9 optional) and M6 on the intake.

Condensate collection and drainage container constructed with AISI 304 stainless steel sheet. Designed for inclusion of heating exchanger inside the unit (ACCESSORY).

AVAILABLE VERSION

RPE - S

Standard version with polyurethane insulation

RPE - X

Extra comfort version with mineral wool insulation and thermal break profile



MAIN COMPONENTS BASE UNIT

Structure

Closing panels made of a double sheet of galvanized steel, pre-painted on the outer surface, completely removable for inspection/maintenance, and with different inlet/outlet configurations;

Internal heat and sound insulation

Made from polyurethane foam (RPE-S δ 38 kg/m³) or mineral wool (RPE-X δ 90 kg/m³) with a thickness of 30 mm. Fire reaction A1 class.

Controller

Power board in control cabinet and display EVO supplied separately, for wall installation.



Heat recovery

Upstream-flow heat recuperator, with aluminium frame, aluminium heat exchanger block with self-distanced fins and sealed at the ends in order to prevent contamination of the fresh air by the expelled air. Condensate collection and drainage container constructed with AISI 304 stainless steel sheet. Minimum heat efficiency 73%, complete with internal bypass damper.

Filter section

-Medium-efficiency filtering section on the room air intake Class M6 (EPM 10 80% ; EN 16890).
- High-efficiency filtering section on the outside air intake Class F7 (EPM 1 50% ; EN 16890).

Fans

Ventilation sections with EC plug-fan with 0-10 V C/C control.

By-pass for free cooling

The heat recovery unit, inside the unit, includes the single-control dual damper for managing the bypass. The damper can be integrated with servo control with on/off control signal (ACCESSORY). Free-cooling operation can be managed by the EVO SYSTEM control.

ACCESSORIES

Regulation

Quality air control (only with Indoor Air Quality (CO₂/VOC), mouted and wired on board)

Control at constant air flow

Control at constant static pressure

Internal coils

Antifreeze heating element (2 steps)

Electric heating coil (2 steps / modulating 0-10 V + NTC control fix point outlet or ambient)

Water heating coil

Water cooling and heating coil only for size 055 and 110

DX coil (R410a) for cooling and heating only for size 055 and 110 (with signal ON/OFF motocondensing / 0-10 Vcc VRF + NTC control outlet or ambient fix point)

External coils

Water cooling and heating coil only for size from 175 to 600

DX coil (R410a) for cooling and heating only for size from 175 to 600 (with signal ON/OFF motocondensing / 0-10 Vcc VRF + NTC control outlet or ambient fix point)

Hydronic coil valves

2 or 3 way modulating valve + NTC control outlet or ambient fix point)(1) (2)

Servomotors

ON/OFF servomotor (mounted, wired and operated) for by-pass

Other accessories

Dampers with ON/OFF servo control on the outside air and exhaust side (fitted, wired and operated)

Support feet (3)

Protection Canopy (4)

Filtration and sanitisation

F9 filter outlet (replacing F7)

Double filtration stage (F7 + F9) outlet

Sanitizing system modul Jonix, cold plasma (2)

(1) 2-3 way valve and actuators are supplied loose (installation and connectors not included).

(2) Power supply cannot be derived from EVO or for 2-3 way modulating valve or for sanitizing system modul Jonix

(3) For horizontal version, indoor, for floor installation (are included on external version and not available for ceiling installation).

(4) The canopy is already included in the outdoor versions.

ATTENTION: the post-heating treatment is NOT available.

Heat recovery unit RPE

RATED TECHNICAL DATA

RPE			55	110	175	220	255	320	410	500	600
			H		H+V					V	
Air flow rate		m ³ /h	550	1100	1750	2200	2550	3200	4100	5000	6000
Maximum available static pressure		Pa	360	330	390	230	400	230	400	190	530
Rated available static pressure		Pa	150	150	150	150	150	150	150	150	150
Sound power level (outlet)	(1)	dB (A)	72,8	77	74,6	79,3	74,2	78,2	82,7	85,8	81,8
HEAT RECOVERY UNIT			Winter operation (balanced air flow)								
Wet efficiency		%	87,7	88,3	90,3	90,3	92,7	92,0	91,7	92,3	92,7
Recovery		Kw	4,85	9,77	15,93	20,03	23,78	29,65	37,8	46,5	56,0
Dry efficiency	(*)	%	75,5	77,9	79,7	79,6	81,4	80,6	80,0	80,2	80,5
Outlet air temperature		°C	16,3	16,5	17,1	17,1	17,8	17,6	17,5	17,7	17,8
			Summer operation (balanced air flow)								
Wet efficiency		%	74,5	76,8	77,3	78	78	78,9	78,4	78,5	78,8
Recovery		Kw	1,25	2,59	4,21	5,29	6,26	7,77	9,9	12,1	14,6
Outlet air temperature		°C	28,2	28,1	27,9	27,9	27,7	27,9	27,8	28	28
FANS											
Number of fans	(2)	n°	2								
Electrical input max	(2)	Kw	0,34	0,68	1	1	1,48	1,48	3	3	4,2
Maximum total power consumption	(2)	A	2,7	5,4	4,4	4,4	7,6	7,6	4,8	4,8	6,8
Protection rating		IP	54								
Insulation class			F								
Power supply		V/ph/Hz	230/1/50	230/1/50	230/1/50	230/1/50	230/1/50	230/1/50	400/3/50	400/3/50	400/3/50

Winter condition

External air temperature -10°C B.S., U.R. 90%

Indoor recirculation temperature 20°C B.S., U.R. 50%

Summer condition

External air temperature 35°C B.S., U.R. 50%

Indoor recirculation temperature 26°C B.S., U.R. 60%

(1) The supply sound power level is calculated at nominal conditions, i.e.: nominal flow rate and external pressure 150 Pa.

(2) Both fans were considered (no. 1 in supply and no. 1 in return).

(*) Thermal efficiency in according with new directive European CE 1253/2014/CE «thermal efficiency of a not residential HRS = ratio between inlet air heat gain and outlet air thermal loss, both referred to external temperature, measured in dry conditions, with a balanced mass flow, and a thermal difference between indoor air / outside air of 20 K, taking not in account the heat gain generated by fan motors and internal leakage.

A AND B ORIENTATIONS HORIZONTAL LAYOUT

ORIENTATION A^(*)

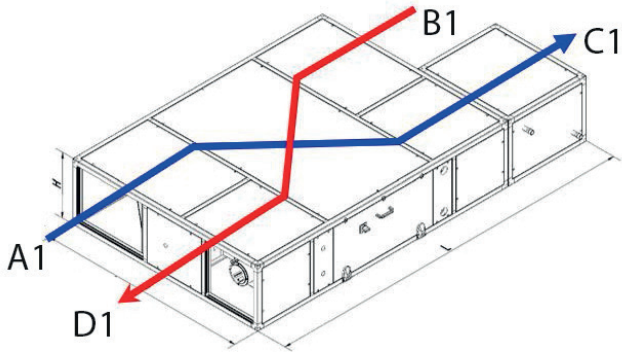

ORIENTATION B^(*)

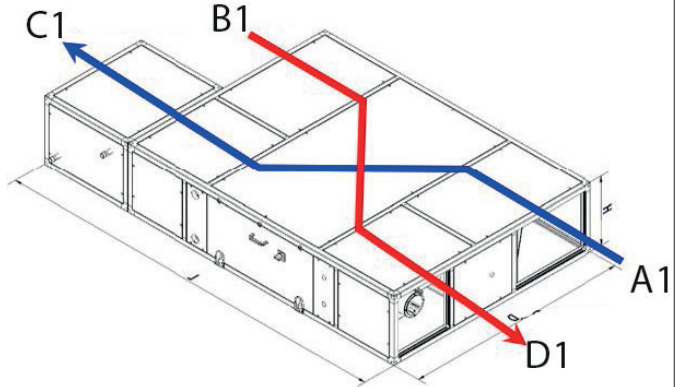

A1: Fresh air
B1: Ricirculation air

C1: Supply air
D1: Exhaust air

A AND B ORIENTATIONS VERTICAL LAYOUT

ORIENTATION A^(*)

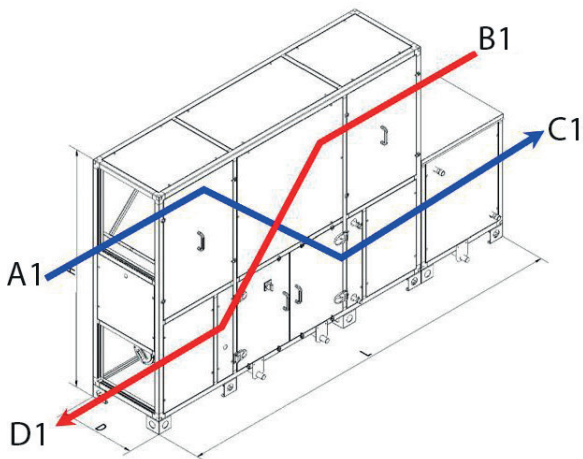

ORIENTATION B^(*)

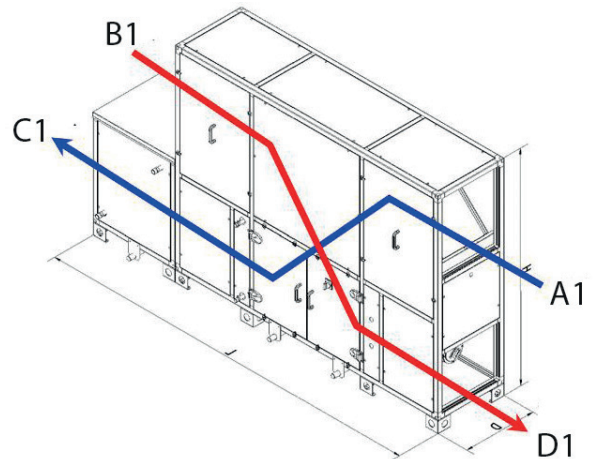

A1: Fresh air
B1: Ricirculation air

C1: Supply air
D1: Exhaust air

* For orientation: referred to coil connection side.

ATTENTION:

Is not possible to change orientation on construction site.
THE ORIENTATION will be defined in order phase.
Otherwise Cetra will proceed with the production of ORIENTATION A.



Heat recovery unit RPE

LAYOUT INPUT/OUTPUT - HORIZONTAL ORIENTATION (top view)

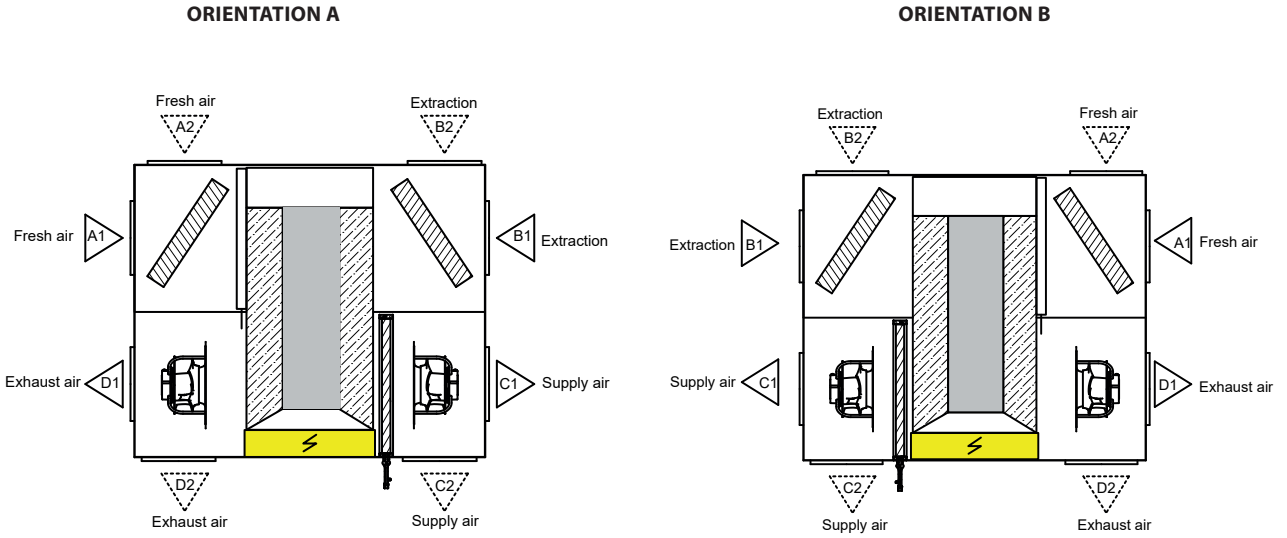

LAYOUT INPUT/OUTPUT - VERTICAL ORIENTATION (front view)

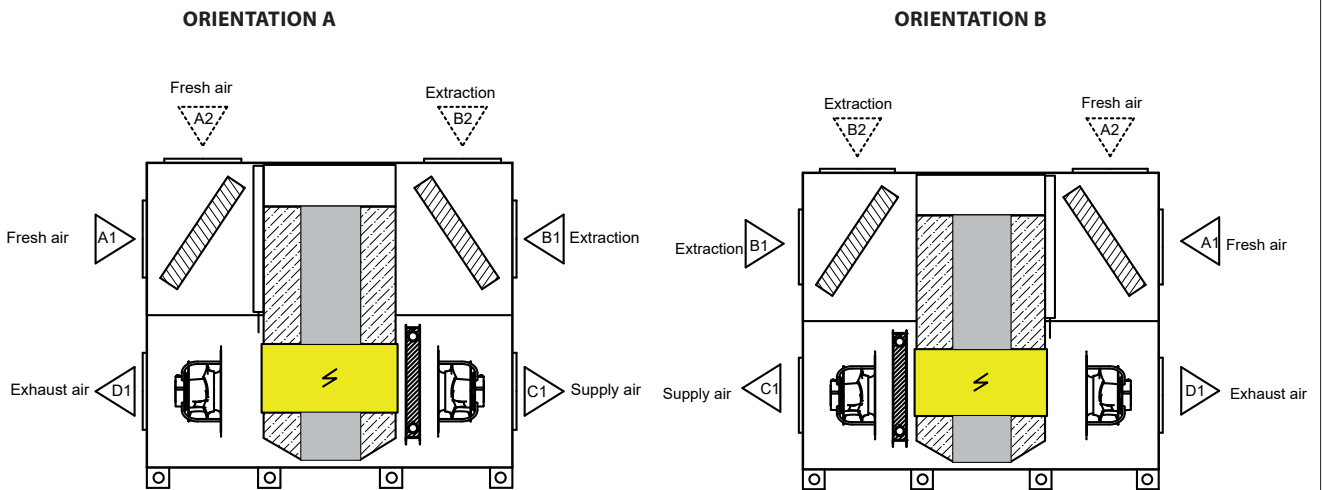

ATTENTION:

If the position for the recuperator input/output is not communicated, Cetra will proceed with the production of A1/B1/C1/D1.

The opening position can be switched on site (e.g. from A1 to A2).

DIMENSIONAL DRAWINGS

RPE HORIZONTAL LAYOUT WITHOUT EXTERNAL MODULE

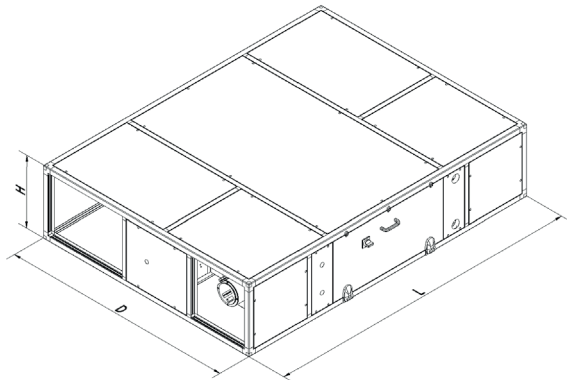

RPE	55 ⁽¹⁾	110 ⁽¹⁾	175	220	255	320
H mm	520*	520*	520*	520*	600*	600*
D mm	1260	1260	1705	1705	2000	2000
L mm	2300	2300	2300	2300	2600	2600
KG	160	180	290	300	430	440

⁽¹⁾Any hydronic cooling and heating coil / DX (R410a) will be mounted only for sizes 055-110.

With horizontal recuperators for ceiling installation, access for maintenance (e.g. for replacing filters and fans) is lateral or from below. Conversely, for those with floor installation, it is only lateral.

RPE HORIZONTAL LAYOUT WITH EXTERNAL MODULE: (ME)

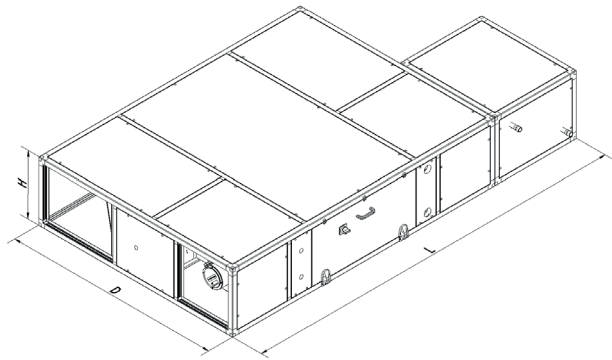

RPE	55	110	175	220	255	320	
H mm	520*	520*	520*	520*	600*	600*	
D mm	1260	1260	1705	1705	2000	2000	
L mm	2800	2800	3020	3020	3270	3270	
KG	RPE	160	180	290	300	430	440
KG	ME	50	50	68	68	82	82

The external module acts as a containment of the hydronic / DX cooling and heating coil (R410a) only for sizes from 175 to 600 - ACCESSORY.

*Consider the additional height of feet = 100 mm, for outdoor application

RPE VERTICAL LAYOUT WITHOUT EXTERNAL MODULE

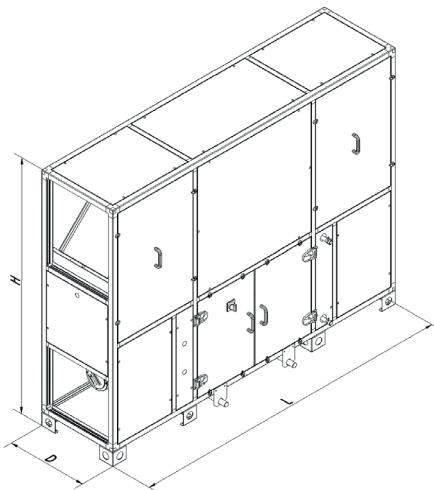

RPE	175	220	255	320	410	500	600
H mm	1805	1805	2100	2100	2100	2100	2100
L mm	2300	2300	2600	2600	2750	2750	2900
D mm	580	580	600	600	800	800	950
KG	290	300	430	440	510	530	620

With vertical recuperators, access for maintenance (ex. for filter and fan replacement) is only from the side.

RPE VERTICAL LAYOUT WITH EXTERNAL MODULE: (ME)

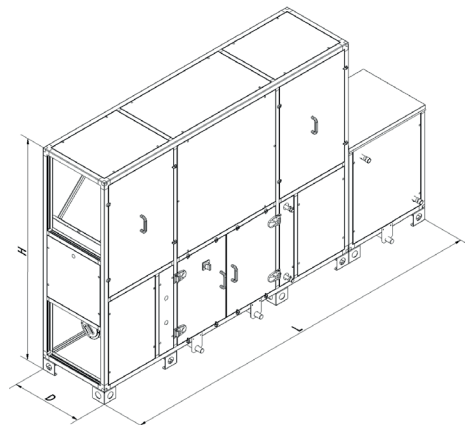

RPE	175	220	255	320	410	500	600	
H mm	1805	1805	2100	2100	2100	2100	2100	
L mm	3020	3020	3270	3270	3420	3420	3570	
D mm	580	580	600	600	800	800	950	
KG	RPE	290	300	430	440	510	530	620
KG	ME	70	70	84	84	90	90	100

The external module acts as a containment of the hydronic / DX cooling and heating coil (R410a) only for sizes from 175 to 600 - ACCESSORY.



A series of horizontal lines for writing, consisting of 25 evenly spaced lines extending across the width of the page.



A series of horizontal lines for writing, consisting of 25 evenly spaced lines extending across the width of the page.



A series of horizontal lines for writing, consisting of 25 evenly spaced lines extending across the width of the page.



A series of horizontal lines for writing, consisting of 25 evenly spaced lines that span the width of the page.



A series of horizontal lines for writing, consisting of 25 evenly spaced lines extending across the width of the page.



A series of horizontal lines for writing, consisting of 25 evenly spaced lines extending across the width of the page.

The dimensional data given herein are approximate.

As part of its commitment to improving products, Galletti S.p.A. reserves the right to introduce changes to technical and/or price list data without notice.

Due to printing, the colours of the products that appear in this document may differ from the actual colours.

All copying, even partial, of this document is strictly forbidden.



Galletti S.p.A.

Via L.Romagnoli, 12/a | 40010 Bentivoglio (BO) ITALY
T +39 051 8908111 | F +39 051 8908122/3
info@galletti.it | www.galletti.com

