

LCC

Water chillers and heat pumps TECHNICAL MANUAL

GB



48kW - 153kW

CE

COMPANY
WITH QUALITY SYSTEM
CERTIFIED BY DNV
=ISO 9001/2000=

 **Galletti**
AIR CONDITIONING

INDEX

1	THE SERIES	2
2	CONSTRUCTIVE FEATURES	3
3	MODELS AND CONFIGURATIONS	5
4	LCC CS RATED TECHNICAL DATA	6
6	LCC CL RATED TECHNICAL DATA	6
6	LCC HS RATED TECHNICAL DATA	7
7	LCC HL RATED TECHNICAL DATA	7
8	LCC CS COOLING CAPACITY	8-9
9	LCC CL COOLING CAPACITY	10-11
10	LCC HS COOLING CAPACITY	12-13
11	LCC HL COOLING CAPACITY	14-15
12	LCC H HEATING CAPACITY	16
13	EVAPORATOR PRESSURE DROP	17
14	CALCULATION FACTOR	17
15	WATER SYSTEM OPTIONS	18-19
16	HEAT RECOVERY OPTIONS	20-21
17	WATER CIRCUIT	22
18	OPERATING LIMITS	23
19	ELETRICAL DATA	25
20	INSPECTION, CONVEYANCE, SITING	26
21	INSTALLATION CLEARANCE REQUIREMENTS	27
22	OVERALL DIMENSIONS	28-31
23	WEIGHTS	31

1 THE SERIES

LCC air cooled water chillers and heat pumps are designed for indoor installation in both residential and industrial applications with 24h/day operation.

The range is made of 10 models only cooling and heat pumps, realized in standard and low noise version, with cooling capacities from 48 to 153 kW and heating capacity from 54 to 168kW.

LCC CS	water chiller, standard version
LCC CL	water chiller, low noise version
LCC HS	heat pump, standard version
LCC HL	heat pump, low noise version
LCC FS	free cooling, standard version
LCC FL	free cooling, low noise version

The design philosophy has favoured the themes of the compactness, turnkey and easy accessibility to all components.

The logic of the hydraulic plug&play, already DNA of the whole water range, is placed side by side with a new aeraulic "plug&play" system: adaptive air flow and modulating continuous fan speed control directed to reduce drastically the installation times.

The wide possibility of air flow configurations, in terms of number of models (sizes) in the range, and the available accessories, make the new range LCC the ideal solution for speeding up the time of installation on the building site. All units are in dual circuit execution and have the evaporator with braze-welded INOX AISI 304, dual circuit on refrigerant side to guarantee high efficiency under partial loads.

DECLARATION OF CONFORMITY 

Galletti S.p.A., whose main office is in Via Romagnoli, 12/a Bentivoglio (BO) - Italy, hereby declares, under its sole responsibility, that the LCC water chillers, devices for air conditioning systems, conform to the specifications of EEC Directives 73/23, 89/392, 91/368, 93/44, 93/68, 97/23, 89/336.

Bologna li, 19/04/2004
Luigi Galletti
President

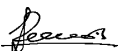

FIELD OF APPLICATION

These machines are designed to cool-heat water and solutions containing up to 30% glycol (percentage by weight) in civil, industrial and technological air-conditioning systems. These machines are designed for indoor applications or installations (where air inlet and outlet are possible) or in any case in sites protected from bad weather conditions.

They must be used in observance of the operating limits specified in this manual; failure to comply with said limits will invalidate the warranties provided in the contract of sale.

2 CONSTRUCTIVE FEATURES

STRUCTURE

The LCC range is built with monoblock supporting base and enclosing panels made of galvanised sheet steel coated in RAL 7016 with epoxy polyester powder paint oven cured at 180°.

The compressor compartment is completely sealed and may be easily accessed from the front side opening the doors of the unit. These are easy-to-remove doors that greatly simplify maintenance and/or inspection.

For lifting the unit, 50 mm holes are provided in the base, through which lifting pipes can be inserted and the vibration damping feet can be accessed for fastening, moreover these are not indispensable thanks to the compressors (scroll) and fans (Plug) technology adopted.

All bolts and screws and fastening devices are made of non-oxidizable materials, stainless steel or carbon steel that has undergone surfacepassivating treatments.



COOLING CIRCUIT

The cooling circuit is built using only components of the finest quality brands produced by qualified manufacturers according to the specifications of Directive 97/23 for brazing.

All the units are built with a dual independent cooling circuit to guarantee high standard safety and a single circuit on water side to ensure maximum energy efficiency under partial loads.

COMPRESSORS

Only scroll-type compressors are used on the LCC units, both in single and tandem configurations, with thermal protection on windings and crankcase electric heater (heat pump).

COOLING COMPONENTS

- Molecular mesh dehydration filter.
- Flow indicator with humidity indicator.
- Thermostatic valve with external equalization and integrated MOP function.
- Electronically controlled electric expansion valve (optional), which optimises energy consumption in in-between seasons.
- Cycle reversing valve (heat pump models only).
- Check valves (heat pump models only).
- Liquid receiver marked as per the Directive 97/23 PED (heat pump models only or unit provided with flooding condensing control system).
- Safety valves as per the Directive 97/23 PED.
- High and low pressure switches.
- Schrader valves for checks and/or maintenance.

HEAT EXCHANGER, WATER SIDE

All units have heat exchangers with braze-welded AISI 304 austenitic stainless steel plates and connections made of AISI 304L, characterized by a reduced carbon content to facilitate brazing, exclusively of the "cross flow" type dual circuit exchanger on the refrigerant side, and single circuit exchanger on the water side to ensure energy efficiency when the system is operating under partial loads.

FINNED BLOCK CONDENSER

Built in the size of 25x21,65 with 3,8" piping, it is made of 0,10 mm aluminium fins and copper piping expanded on the same to guarantee the complete contact. The condensing coil can be provided with a metallic filter, easy-to-remove from the unit sides even in case of ducted suction.

In the heat pump version, the special engineering of the heat exchangers allows defrost cycle to be carried out at maximum speed, with clear benefits in terms of the integrated efficiency of the whole cycle.

The model with heat pump operation are provided with a drip tray for condensing in stainless steel which is also ductable in this case we suggest the installation of a PTC-type heating cable in the first piping section to avoid blocks due to the ice.



VENTILATION SECTION

The units comprise centrifugal fans with backward curved blades coupled to an high efficiency external rotor motor.

The fan with backward blades is characterized by an high reaction grade (the energy is mainly transmitted as pressure energy), which allows to obtain static efficiencies of 5-6 points % higher than the solution with forward curved blades and scroll.

A very important aspect is the characteristic, proper of these fans (a), to decrease the power absorption by decreasing of the back-pressure; these means the end of the risk to overload the motors in case of ducts break, which happens using forward curved (traditional) centrifugal fans (b).

The fans are statically and dynamically balanced mounted with interposed rubber vibration dampers to reduce the propagation of vibrations during speed-modulating phases.

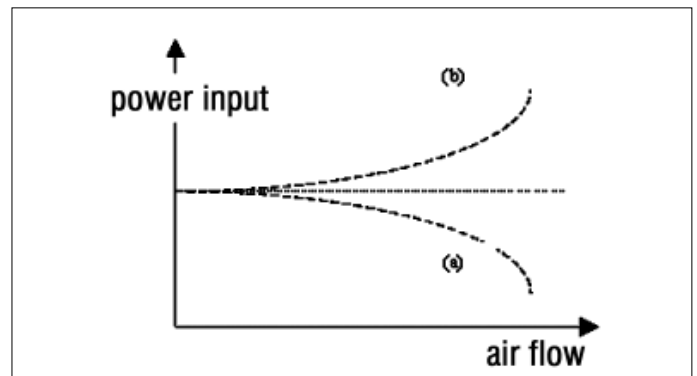

All the fans are equipped with 4 poles motors of the external rotor type, which ensure maximum energy efficiency and reduced magnetic noise in the event they are controlled with a potentiometer (optional).

The fans are made of aluminium and the motors are protected with a chain of thermistors acting directly on the solenoid of their remote control switch. The position of the fans allows a very easy air outlet from the top, towards the coil, lateral and also (optional execution) towards the access side.

2 CONSTRUCTIVE FEATURES

ELECTRIC CONTROL BOARD

Constructed and wired in accordance with EEC Directive 73/23, Directive 89/336 on electromagnetic compatibility and related standards.

The electric box may be accessed by removing the outer panel; access to the components is possible only after the unit has been disconnected from the power supply by means of the main switch, which is interlocked with the door.

The control board is equipped with an air circulation system that is active while the unit is running.

All the remote controls use 24 V signals powered by an insulating transformer situated on the electric control board.

All users are protected against overloads and short circuits; thermal protection is provided by chains of thermistors embedded in the windings of each electric motor. Another standard feature of all units is a phase sequence relay, which disables the compressor in the event of an incorrect phase sequence: for scroll compressors, only one direction of rotation is possible. The protection rating of the unit is IP 44 and the control board with the panel open has a protection rating of IP20.

The electric control board houses two manual selector switches for enabling remote on-off control and seasonal switchovers (only heat pump models): the remote controls work with extremely low-voltage contacts situated in the terminal board section. The terminal board also includes terminals for remote signalling of:

- unit on/off (24 V lamp)
- alarms (24 V lamp).

CONTROL MICROPROCESSOR

LCC water chillers and heat pumps are supplied complete with a microprocessor control. the "Basic" version installed in standard units features the following functions:

- control of the different operating parameters from a set of pushbuttons situated on the electric control board;
- switching on and off of compressors to maintain the set temperature of the water entering the water/refrigerant exchanger;
- display of operating parameters;
- alarm management and signalling
 - high / low pressure
 - antifreeze
 - flow switch
 - pump alarm
- control of maximum number of compressor starts;
- rotation of compressors, activated in sequence to divide up their operating times;
- compressor operation hour meter;
- RS232, RS485 serial output management on request.

On request, the units can be equipped with Advanced microprocessor control, which in addition to the functions described above offers the possibility of custom software features ensuring optimal satisfaction of all system demands.



As regards remote communication options, the controls are configured for a connection to advanced BMS systems. The possibilities of interconnectivity offered by the system may be summed up as follows:

Serial ports available with **Basic** control

- RS232
- RS485

GSM Modem: with prepaid card and antenna on the unit for autonomous two-way management of alarms and/or set point adjustment.

Protocols

- Carel (incorporated)
- Modbus® (Incorporated with **Advanced** control)]
- Modbus® (With external gateway with **Basic** control)
- LonWorks® (Dedicated serial card to be requested when ordering the unit)
- BACnet™ (with external gateway)
- TCP-IP (with external gateway)
- TREND® [Dedicated serial card to be requested when ordering the unit]

WATER CIRCUIT

All the units have a single (in+out) plumbing connection to the outside this feature is important as it reduces the time necessary for making connections on the installation site.

A water flow control device is included as standard feature of all units. In the event the water flow is cut off, it immediately interrupts operation to prevent freezing and the consequent damage that would be caused to the plate exchanger.

In addition to this device, every plate heat exchanger is fitted with an outlet water temperature sensor, which performs the function of an antifreeze thermostat.

On request, all units making up the LCC series can be supplied with a broad range of single or dual pumps for operating at temperatures as low as -10°C , with a maximum percentage of glycol of 35%, and inertial storage reservoirs: the storage reservoir is placed on the water circuit outlet and helps attenuate the inevitable temperature fluctuations occurring as a result of the switching on and off of the compressors.

If a dual pump (optional) is installed, the built-in microprocessor automatically controls their rotation on a time and/or fault basis: in the latter case, a low-priority alarm is signalled on the terminal board and the external warning LED (on the front of the unit) lights up.

The pump system is incorporated in the structure of the unit and is arranged so as to ensure that the pump motors are always cooled by outside air, as illustrated in the figure.

Outside air (arrow on the right) enters through the duct provided and cools the motor.

Otherwise the motor would be exposed to hot air leaving the condensing coils, which would prevent the pump motor/motors from being properly cooled.

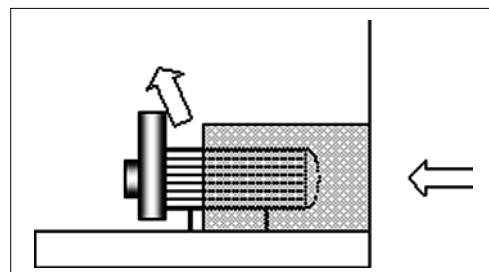

3 MODELS AND CONFIGURATIONS

The LCC series is made of 10 models, cooling and heat pump, standard and low noise version. The number of constructive options can be selected using the configuration selector below .

The choice of some options can prevent the choice of others or render obligatory other fields. To contact the Galletti for verification

Complete model name	L	C	C	0	8	0	C	S	0	0	0	0	0	0	R	0	0	0	0	0	0	0	0	0
Model	0	8	0																					
Operation	C																							
Cooling only	C																							
Heat pump	H																							
Free-Cooling	F																							
Version	S																							
standard with modulating condensing control	S																							
Low noise with modulating condensing control	L																							
Refrigerant / Power supply	0																							
R407C - 400/3/50 with 230V built in transformer	0																							
R22 - 400/3/50 with 230V built in transformer	1																							
R407C - 400/3/50 with 230V built in transformer, thermal-magnetic	2																							
R22 - 400/3/50 with 230V built in transformer, thermal-magnetic	3																							
Microprocessor / expansions devices	0																							
Basic (μchiller) + traditional valve	0	*																						
Basic (μchiller) + electronic valve	A	*																						
Advanced (pCO) + traditional valve	B																							
Advanced (pCO) + electronic valve	C																							
Water pump	0																							
not present	0																							
Pump and expansion vessel	1	*																						
Double pump and expansion vessel	2	*																						
Uprated pump and expansion vessel	3																							
Double uprated pump and expansion vessel	4																							
Water tank	0																							
not present	0																							
present	S	*																						
Heat Recover (with condensing control)	0																							
not present	0																							
partial (desuperheater) 40%	D																							
Condensing and air flow control	R																							
Rear side air discharge	R																							
Vertical air discharge	H																							
Remote communication	0																							
not present	0																							
RS232 (only for the pCO1 control)	1																							
RS 485	2																							
Compressors options	0																							
not present	0																							
Power factor correction capacitors	K																							
kit soft-starter	A																							
Power factor correction capacitors + kit soft starter	M																							
Condenser protection	0																							
not present	0																							
condenser protection grille	G																							
air filter for condenser	F																							
Remote control	0																							
not present	0																							
Simplified	S																							
with μChiller microprocessor	M																							
with pCO microprocessor	P																							
Flanges	0																							
not present	0																							
Outlet flanges	M																							
Inlet flanges	A																							
Outlet and inlet flanges	T																							
Package	0																							
Standard	0																							
Wooden crate	G																							
Wooden box	C																							
Accessories	0																							
not present	0																							
Base vibration dampers	A																							
Pressure gauges	M																							
Base vibration dampers + Pressure gauges	T																							
Documentation language	0																							
italian	0																							
english	1																							
german	2																							
other	S																							
Special manufacture	0																							
Standard	0																							
special	S																							

* Not available for FREE COOLING version

4 LCC-CS RATED TECHNICAL DATA

LCC - CS		50	60	70	80	90	105	115	130	145	160
Cooling capacity	kW	48,7	56,0	65,2	68,8	88,2	98,0	109,1	125,9	143,0	152,8
Rated electrical input	kW	22,4	25,9	28,0	32,8	38,5	44,8	51,1	56,2	63,9	71,4
Rated current absorption	A	41,2	46,0	49,2	58,0	67,3	76,6	86,9	94,6	106,1	117,4
Power supply	V - ph - Hz	400-3-50 + N									
Maximum current absorption	A	65	69	73	79	98	113	142	160	178	192
Starting current	A	163	171	190	214	269	291	346	378	415	446
Number of scroll compressors/circuits	n°	2/2	2/2	2/2	2/2	2/2	2/2	2/2	2/2	2/2	2/2
Axial fans	n°	2	2	2	2	3	3	3	3	3	3
Air flow rate	m ³ /h	17500	19000	19000	19000	27000	27000	36000	36000	40000	40000
Available static pressure	Pa	400	310	250	250	290	290	250	250	150	150
Front surface of condenser coils	m ²	2,3	2,3	2,3	2,3	2,8	2,8	3,6	3,6	3,6	3,6
Evaporator	n°	1	1	1	1	1	1	1	1	1	1
Water flow rate	l/h	8377	9631	11215	11833	15171	16855	18765	21654	24596	26281
Pressure drops, water side	kPa	30	26	35	28	29	34	30	35	31	36
Water content, excluding optionals	dm ³	6,1	6,6	7,1	7,9	32,0	33,5	34,1	36,2	38,1	40,2
Buffer tank (optional)	dm ³	340	340	340	340	340	340	340	340	340	340
Hidraulic connection type		GAS	GAS	GAS	GAS	GAS	GAS	Victaulic	Victaulic	Victaulic	Victaulic
Plumbing connections	inches	2"	2"	2"	2"	2"	2"	3"	3"	3"	3"
Sound power level	dB A	79	81	81	81	82	82	86	86	89	89
Sound pressure level	dB A	71	73	73	73	74	74	78	78	81	81
Dimensions: height	mm	2020	2020	2020	2020	2020	2020	2020	2020	2020	2020
Dimensions: length	mm	2000	2000	2000	2000	2400	2400	3090	3090	3090	3090
Dimensions: depth	mm	1100	1100	1100	1100	1100	1100	1100	1100	1100	1100

5 LCC-CL RATED TECHNICAL DATA

LCC - CL		50	60	70	80	90	105	115	130	145	160
Cooling capacity	kW	48,7	56,0	65,2	68,8	88,2	98,0	109,1	125,9	143,0	152,8
Rated electrical input	kW	20,5	24,5	26,8	31,6	36,7	43,1	46,7	51,8	60,8	68,3
Rated current absorption	A	40,8	46,9	50,7	59,6	69,6	78,1	88,6	96,9	112,2	123,5
Power supply	V - ph - Hz	400-3-50 + N									
Maximum current absorption	A	65	69	73	79	98	113	142	160	178	192
Starting current	A	163	171	190	214	269	291	346	378	415	446
Number of scroll compressors/circuits	n°	2/2	2/2	2/2	2/2	2/2	2/2	2/2	2/2	2/2	2/2
Axial fans	n°	2	2	2	2	3	3	3	3	3	3
Air flow rate	m ³ /h	17500	19000	19000	19000	27000	27000	36000	36000	40000	40000
Available static pressure	Pa	400	310	250	250	290	290	250	250	150	150
Front surface of condenser coils	m ²	2,3	2,3	2,3	2,3	2,8	2,8	3,6	3,6	3,6	3,6
Evaporator	n°	1	1	1	1	1	1	1	1	1	1
Water flow rate	l/h	8377	9631	11215	11833	15171	16855	18765	21654	24596	26281
Pressure drops, water side	kPa	30	26	35	28	29	34	30	35	31	36
Water content, excluding optionals	dm ³	6,1	6,6	7,1	7,9	32,0	33,5	34,1	36,2	38,1	40,2
Buffer tank (optional)	dm ³	340	340	340	340	340	340	340	340	340	340
Hidraulic connection type		GAS	GAS	GAS	GAS	GAS	GAS	Victaulic	Victaulic	Victaulic	Victaulic
Plumbing connections	inches	2"	2"	2"	2"	2"	2"	3"	3"	3"	3"
Sound power level	dB A	75	77	77	77	78	78	79	79	83	83
Sound pressure level	dB A	67	69	69	69	70	70	71	71	75	75
Dimensions: height	mm	2020	2020	2020	2020	2020	2020	2020	2020	2020	2020
Dimensions: length	mm	2000	2000	2000	2000	2400	2400	3090	3090	3090	3090
Dimensions: depth	mm	1100	1100	1100	1100	1100	1100	1100	1100	1100	1100

- Cooling capacity: outdoor air temperature 35°C, water temperature 12°C/7°C, Sound power measured according to standards ISO 3741 - ISO 3744 and EN 29614-1, Sound pressure measured at a distance of 1 m and a height of 1.5 m above the ground in an open field, available static pressure 100 Pa

6 LCC-HS RATED TECHNICAL DATA

LCC - HS		50	60	70	80	90	105	115	130	145	160
Cooling capacity	kW	47,2	54,3	63,2	66,7	85,6	95,1	105,8	122,1	138,7	148,2
Rated electrical input in cooling mode	kW	22,4	25,9	28,0	32,8	38,5	44,8	51,1	56,2	63,9	71,4
Rated current absorption in cooling mode	A	41,2	46,0	49,2	58,1	67,3	76,3	86,3	94,6	106,1	117,4
Heating capacity	kW	54,0	61,6	72,2	79,8	97,2	108,0	129,0	139,8	155,0	168,0
Rated electrical input in heating mode	kW	22,0	24,6	27,6	30,8	37,5	42,3	50,7	54,9	59,6	64,9
Rated current absorption in heating mode	A	40,7	44,4	48,7	55,3	66,1	73,0	85,8	93,0	100,4	108,6
Power supply	V - ph - Hz	400-3-50 + N									
Starting current	A	-	-	-	-	-	113	142	160	178	192
Starting current	A	163	171	190	214	269	291	346	378	415	446
Number of compressors/circuits	n°	2/2	2/2	2/2	2/2	2/2	2/2	2/2	2/2	2/2	2/2
Axial fans	n°	2,0	2,0	2,0	2,0	3,0	3,0	3,0	3,0	3,0	3,0
Air flow rate	m ³ /h	17500	19000	19000	19000	27000	27000	36000	36000	40000	40000
Available static pressure	Pa	400	310	250	250	290	290	250	250	150	150
Front surface of condenser coils	m ²	2,3	2,3	2,3	2,3	2,8	2,8	3,6	3,6	3,6	3,6
R407C/water exchanger	n°	1,0	1,0	1,0	1,0	1,0	1,0	1,0	1,0	1,0	1,0
Water flow rate in cooling mode	l/h	8120	9342	10879	11478	14715	16350	18202	21004	23857	25493
Pressure drops, water side in cooling mode	kPa	30	26	35	28	29	34	30	35	31	36
Water flow rate in heating mode	l/h	9288	10596	12418	13725	16719	18576	22189	24046	26660	28896
Pressure drops, water side in heating mode	kPa	34	32	40	35	32	39	36	42	35	40
Water content, excluding optionals	dm ³	6,1	6,6	7,1	7,9	32,0	33,5	34,1	36,2	38,1	40,2
Buffer tank (optional)	dm ³	340	340	340	340	340	340	340	340	340	340
Plumbing connections type		GAS	GAS	GAS	GAS	GAS	GAS	Victaulic	Victaulic	Victaulic	Victaulic
Plumbing connections	inches	2"	2"	2"	2"	2"	2"	3"	3"	4"	4"
Sound power level	dB A	79	81	81	81	82	82	86	86	89	89
Sound pressure level	dB A	71	73	73	73	74	74	78	78	81	81
Dimensions: height	mm	2020	2020	2020	2020	2020	2020	2020	2020	2020	2020
Dimensions: length	mm	2000	2000	2000	2000	2400	2400	3090	3090	3090	3090
Dimensions: depth	mm	1100	1100	1100	1100	1100	1100	1100	1100	1100	1100

7 LCC-HL RATED TECHNICAL DATA

LCC - HL		50	60	70	80	90	105	115	130	145	160
Cooling capacity	kW	47,2	54,3	63,2	66,7	85,6	95,1	105,8	122,1	138,7	148,2
Rated electrical input in cooling mode	kW	20,5	24,5	26,8	31,6	36,7	44,8	51,1	56,2	63,9	71,4
Rated current absorption in cooling mode	A	40,8	46,9	50,7	59,6	69,6	76,3	86,3	94,6	106,1	117,4
Heating capacity	kW	54,0	61,6	72,2	79,8	97,2	108,0	129,0	139,8	155,0	168,0
Rated electrical input in heating mode	kW	22,0	24,6	27,6	30,8	37,5	42,3	50,7	54,9	59,6	64,9
Rated current absorption in heating mode	A	40,7	44,4	48,7	55,3	66,1	73,0	85,8	93,0	100,4	108,6
Power supply	V - ph - Hz	400-3-50 + N									
Starting current	A	-	-	-	-	-	113,0	142,0	160,0	178,0	192,0
Starting current	A	163	171	190	214	269	291	346	378	415	446
Number of compressors/circuits	n°	2/2	2/2	2/2	2/2	2/2	2/2	2/2	2/2	2/2	2/2
Axial fans	n°	2	2	2	2	3	3	3	3	3	3
Air flow rate	m ³ /h	17500	19000	19000	19000	27000	27000	36000	36000	40000	40000
Available static pressure	Pa	400	310	250	250	290	290	250	250	150	150
Front surface of condenser coils	m ²	2,3	2,3	2,3	2,3	2,8	2,8	3,6	3,6	3,6	3,6
R407C/water exchanger	n°	1	1	1	1	1	1	1	1	1	1
Water flow rate in cooling mode	l/h	8120	9342	10879	11478	14715	16350	18202	21004	23857	25493
Pressure drops, water side in cooling mode	kPa	30	26	35	28	29	34	30	35	31	36
Water flow rate in heating mode	l/h	9288	10596	12418	13725	16719	18576	22189	24046	26660	28896
Pressure drops, water side in heating mode	kPa	34	32	40	35	32	39	36	42	35	40
Water content, excluding optionals	dm ³	6,1	6,6	7,1	7,9	32,0	33,5	34,1	36,2	38,1	40,2
Buffer tank (optional)	dm ³	340	340	340	340	340	340	340	340	340	340
Plumbing connections type		GAS	GAS	GAS	GAS	GAS	GAS	Victaulic	Victaulic	Victaulic	Victaulic
Plumbing connections	inches	2"	2"	2"	2"	2"	2"	3"	3"	4"	4"
Sound power level	dB A	75	77	77	77	78	78	79	79	83	83
Sound pressure level	dB A	67	69	69	69	70	70	71	71	75	75
Dimensions: height	mm	2020	2020	2020	2020	2020	2020	2020	2020	2020	2020
Dimensions: length	mm	2000	2000	2000	2000	2400	2400	3090	3090	3090	3090
Dimensions: depth	mm	1100	1100	1100	1100	1100	1100	1100	1100	1100	1100

- Cooling capacity: outdoor air temperature 35°C, water temperature 12°C / 7°C, Heating capacity: outdoor air temperature 7°C dry bulb and 6.2°C wet bulb, water temperature 40°C/ 45°C, Sound power measured according to standards ISO 3741 - ISO 3744 and EN 29614-1 Sound pressure measured at a distance of 1 m and a height of 1.5 m above the ground in an open field, available static pressure 100 Pa

8 LCC CS COOLING CAPACITY

- Tw₁ Water inlet temperature
- Tw₂ Water outlet temperature
- Tbs₁ Dry bulb air temperature
- PF Cooling capacity
- PA Power input

LCC	Tbs ₁		25		30		35		40		45	
	Tw ₁	Tw ₂	PF	PA	PF	PA	PF	PA	PF	PA	PF	PA
	°C	°C	kW	kW	kW	kW	kW	kW	kW	kW	kW	kW
LCC 50 CS	10	5	51,94	18,68	48,81	20,31	45,58	22,12	42,31	24,17	38,85	26,38
	11	6	47,07	22,26	50,41	20,43	53,56	18,83	43,68	24,33	-	-
	12	7	55,30	18,94	52,04	20,56	48,70	22,39	45,07	24,48	-	-
	13	8	57,07	19,04	53,83	20,67	50,25	22,53	46,59	24,57	-	-
	14	9	58,79	19,19	55,53	20,79	51,83	22,66	48,03	24,78	-	-
	15	10	60,77	19,29	57,16	20,96	53,56	22,79	49,61	24,86	-	-
	16	11	62,55	19,44	58,92	21,07	55,19	22,92	51,09	25,06	-	-
LCC 60 CS	10	5	59,65	21,43	56,16	23,31	52,64	25,44	48,88	27,86	44,97	30,42
	11	6	61,75	21,57	58,13	23,47	54,36	25,62	50,45	28,05	-	-
	12	7	63,66	21,76	60,02	23,63	56,00	25,86	52,18	28,25	-	-
	13	8	65,60	21,95	61,83	23,84	57,89	25,97	53,70	28,50	-	-
	14	9	67,68	22,09	63,82	24,05	59,73	26,21	55,48	28,61	-	-
	15	10	69,81	22,23	65,81	24,21	61,45	26,45	57,18	28,85	-	-
	16	11	72,03	22,43	67,85	24,37	63,48	26,62	58,91	29,02	-	-
LCC 70 CS	10	5	69,04	23,14	65,15	25,22	61,21	27,59	57,08	30,26	52,84	33,15
	11	6	71,31	23,31	67,23	25,43	63,22	27,80	58,93	30,48	-	-
	12	7	73,70	23,53	69,58	25,62	65,21	28,04	60,91	30,75	-	-
	13	8	76,08	23,70	71,77	25,83	67,30	28,25	62,84	30,97	-	-
	14	9	78,39	23,92	73,99	26,05	69,59	28,45	64,80	31,20	-	-
	15	10	80,88	24,09	76,44	26,27	71,70	28,70	66,73	31,47	-	-
	16	11	83,29	24,32	78,75	26,49	73,85	28,94	68,92	31,69	-	-
LCC 80 CS	10	5	73,77	26,98	69,39	29,44	64,58	32,20	59,60	35,27	54,72	38,36
	11	6	76,05	27,24	71,58	29,69	66,66	32,45	61,64	35,55	-	-
	12	7	78,55	27,50	73,74	29,99	68,80	32,78	63,59	35,81	-	-
	13	8	81,05	27,70	76,07	30,21	70,96	33,04	65,56	36,16	-	-
	14	9	83,59	28,00	78,49	30,51	73,07	33,34	67,56	36,43	-	-
	15	10	86,11	28,24	80,76	30,82	75,39	33,64	69,60	36,69	-	-
	16	11	88,62	28,51	83,25	31,12	77,49	33,98	71,66	37,04	-	-
LCC 90 CS	10	5	93,52	32,20	88,17	34,86	82,55	37,85	76,76	41,16	70,75	44,76
	11	6	96,60	32,44	90,98	35,17	85,24	38,16	79,25	41,50	-	-
	12	7	99,59	32,76	93,93	35,45	88,20	38,47	81,98	41,85	-	-
	13	8	103,04	33,01	97,17	35,73	91,01	38,78	84,57	42,19	-	-
	14	9	106,16	33,34	100,08	36,09	93,79	39,14	87,42	42,54	-	-
	15	10	109,51	33,59	103,23	36,38	96,62	39,50	90,01	42,94	-	-
	16	11	112,76	33,92	106,49	36,75	99,83	39,83	92,65	43,35	-	-
	17	12	116,06	34,25	109,75	37,04	102,67	40,24	95,67	43,70	-	-

8 LCC CS COOLING CAPACITY

T_{w1} Water inlet temperature
 T_{w2} Water outlet temperature
 T_{bs1} Dry bulb air temperature
 PF Cooling capacity
 PA Power input

LCC	T_{bs1}		25		30		35		40		45	
	T_{w1}	T_{w2}	PF	PA	PF	PA	PF	PA	PF	PA	PF	PA
	°C	°C	kW	kW	kW	kW	kW	kW	kW	kW	kW	kW
LCC 105 CS	10	5	104,20	37,34	98,14	40,44	91,84	43,93	85,36	47,92	78,79	51,85
	11	6	107,58	37,70	101,21	40,89	94,91	44,42	88,15	48,35	-	-
	12	7	111,03	38,07	104,52	41,25	98,00	44,82	91,13	48,81	-	-
	13	8	114,73	38,48	107,97	41,71	100,95	45,32	93,96	49,28	-	-
	14	9	118,23	38,90	111,22	42,17	104,21	45,83	96,94	49,69	-	-
	15	10	121,80	39,32	114,81	42,65	107,49	46,24	99,78	50,21	-	-
	16	11	125,43	39,75	118,20	43,12	110,63	46,76	103,13	50,64	-	-
LCC 115 CS	10	5	118,61	41,07	108,66	46,63	102,06	50,25	95,48	54,33	88,46	58,70
	11	6	123,04	41,16	112,25	47,02	105,66	50,68	98,68	54,74	-	-
	12	7	122,41	43,99	115,93	47,41	109,10	51,11	101,87	55,20	-	-
	13	8	126,33	44,39	119,70	47,80	112,52	51,59	105,13	55,68	-	-
	14	9	130,34	44,80	123,46	48,24	116,38	52,04	108,72	56,16	-	-
	15	10	134,64	45,25	127,69	48,69	120,07	52,48	112,13	56,64	-	-
	16	11	138,91	45,62	131,60	49,10	123,82	52,92	115,87	57,14	-	-
LCC 130 CS	10	5	132,42	47,26	125,57	51,08	118,09	55,21	110,17	59,68	102,07	64,36
	11	6	136,72	47,72	129,59	51,58	121,94	55,70	114,00	60,23	-	-
	12	7	141,24	48,14	133,84	52,04	125,90	56,19	117,66	60,77	-	-
	13	8	145,67	48,67	138,29	52,61	130,14	56,76	121,41	61,32	-	-
	14	9	150,32	49,14	142,76	53,07	134,19	57,32	125,13	61,94	-	-
	15	10	155,41	49,63	147,09	53,64	138,31	57,89	129,21	62,58	-	-
	16	11	160,14	50,16	151,73	54,11	142,82	58,47	133,22	63,14	-	-
LCC 145 CS	10	5	151,55	53,69	143,24	57,90	134,42	62,58	125,16	67,85	115,90	73,08
	11	6	156,32	54,22	147,47	58,54	138,74	63,23	129,31	68,48	-	-
	12	7	161,28	54,83	152,31	59,14	143,00	63,87	133,22	69,15	-	-
	13	8	166,06	55,43	156,92	59,74	147,27	64,52	137,40	69,84	-	-
	14	9	171,00	56,04	161,51	60,40	151,56	65,18	141,52	70,51	-	-
	15	10	175,92	56,66	166,54	61,08	156,28	65,93	145,59	71,18	-	-
	16	11	181,52	57,30	171,30	61,76	160,80	66,60	149,99	71,93	-	-
LCC 160 CS	10	5	163,32	59,95	153,80	64,61	143,87	69,91	133,93	75,91	123,68	81,72
	11	6	168,14	60,56	158,57	65,35	148,27	70,27	137,74	76,65	-	-
	12	7	173,23	61,31	163,22	66,02	152,80	71,38	142,13	77,31	-	-
	13	8	178,25	61,99	167,97	66,70	157,31	72,21	146,08	78,12	-	-
	14	9	183,56	62,70	172,97	67,47	161,60	73,04	150,55	78,86	-	-
	15	10	188,70	63,41	177,72	68,24	166,01	73,88	154,81	79,58	-	-
	16	11	193,89	64,13	182,84	69,10	170,82	74,74	158,99	80,30	-	-
	17	199,16	64,86	187,71	69,89	175,77	75,60	163,66	81,10	-	-	

9 LCC CL COOLING CAPACITY

- Tw₁ Water inlet temperature
- Tw₂ Water outlet temperature
- Tbs₁ Dry bulb air temperature
- PF Cooling capacity
- PA Power input

LCC	Tbs ₁		25		30		35		40		45	
	Tw ₁	Tw ₂	PF	PA	PF	PA	PF	PA	PF	PA	PF	PA
	°C	°C	kW	kW	kW	kW	kW	kW	kW	kW	kW	kW
LCC 50 CL	10	5	51,94	16,82	48,81	18,45	45,58	20,26	42,31	22,31	38,85	24,52
	11	6	47,07	16,97	50,41	18,57	53,56	20,40	43,68	22,47	-	-
	12	7	55,30	17,08	52,04	18,70	48,70	20,50	45,07	22,62	-	-
	13	8	57,07	17,18	53,83	18,81	50,25	20,67	46,59	22,71	-	-
	14	9	58,79	17,33	55,53	18,93	51,83	20,80	48,03	22,92	-	-
	15	10	60,77	17,43	57,16	19,10	53,56	20,93	49,61	23,00	-	-
	16	11	62,55	17,58	58,92	19,21	55,19	21,06	51,09	23,20	-	-
LCC 60 CL	17	12	64,61	17,68	60,85	19,33	56,86	21,19	52,74	23,26	-	-
	10	5	59,65	20,03	56,16	21,91	52,64	24,04	48,88	26,46	44,97	29,02
	11	6	61,75	20,17	58,13	22,07	54,36	24,22	50,45	26,65	-	-
	12	7	63,66	20,36	60,02	22,23	56,00	24,46	52,18	26,85	-	-
	13	8	65,60	20,55	61,83	22,44	57,89	24,57	53,70	27,10	-	-
	14	9	67,68	20,69	63,82	22,65	59,73	24,81	55,48	27,21	-	-
	15	10	69,81	20,83	65,81	22,81	61,45	25,05	57,18	27,45	-	-
LCC 70 CL	16	11	72,03	21,03	67,85	22,97	63,48	25,22	58,91	27,62	-	-
	17	12	74,12	21,22	69,80	23,19	65,40	25,39	60,81	27,78	-	-
	10	5	69,04	21,94	65,15	24,02	61,21	26,39	57,08	29,06	52,84	31,95
	11	6	71,31	22,11	67,23	24,23	63,22	26,60	58,93	29,28	-	-
	12	7	73,70	22,33	69,58	24,42	65,21	26,84	60,91	29,55	-	-
	13	8	76,08	22,50	71,77	24,63	67,30	27,05	62,84	29,77	-	-
	14	9	78,39	22,72	73,99	24,85	69,59	27,25	64,80	30,00	-	-
LCC 80 CL	15	10	80,88	22,89	76,44	25,07	71,70	27,50	66,73	30,27	-	-
	16	11	83,29	23,12	78,75	25,29	73,85	27,74	68,92	30,49	-	-
	17	12	85,74	23,35	81,05	25,55	76,20	27,99	71,00	30,71	-	-
	10	5	73,77	25,78	69,39	28,24	64,58	31,00	59,60	34,07	54,72	37,16
	11	6	76,05	26,04	71,58	28,49	66,66	31,25	61,64	34,35	-	-
	12	7	78,55	26,30	73,74	28,79	68,80	31,58	63,59	34,61	-	-
	13	8	81,05	26,50	76,07	29,01	70,96	31,84	65,56	34,96	-	-
LCC 90 CL	14	9	83,59	26,80	78,49	29,31	73,07	32,14	67,56	35,23	-	-
	15	10	86,11	27,04	80,76	29,62	75,39	32,44	69,60	35,49	-	-
	16	11	88,62	27,31	83,25	29,92	77,49	32,78	71,66	35,84	-	-
	17	12	91,16	27,58	85,59	30,23	79,79	33,13	73,77	36,10	-	-
	10	5	93,52	30,43	88,17	33,09	82,55	36,08	76,76	39,39	70,75	42,99
	11	6	96,60	30,67	90,98	33,40	85,24	36,39	79,25	39,73	-	-
	12	7	99,59	30,99	93,93	33,68	88,20	36,70	81,98	40,08	-	-
LCC 90 CL	13	8	103,04	31,24	97,17	33,96	91,01	37,01	84,57	40,42	-	-
	14	9	106,16	31,57	100,08	34,32	93,79	37,37	87,42	40,77	-	-
	15	10	109,51	31,82	103,23	34,61	96,62	37,73	90,01	41,17	-	-
	16	11	112,76	32,15	106,49	34,98	99,83	38,06	92,65	41,58	-	-
	17	12	116,06	32,48	109,75	35,27	102,67	38,47	95,67	41,93	-	-

9 LCC CL COOLING CAPACITY

Tw₁ Water inlet temperature
 Tw₂ Water outlet temperature
 Tbs₁ Dry bulb air temperature
 PF Cooling capacity
 PA Power input

LCC	Tbs ₁		25		30		35		40		45	
	Tw ₁	Tw ₂	PF	PA	PF	PA	PF	PA	PF	PA	PF	PA
	°C	°C	kW	kW	kW	kW	kW	kW	kW	kW	kW	kW
LCC 105 CL	10	5	101,07	31,22	95,19	34,32	89,08	37,81	82,79	41,80	76,42	45,73
	11	6	104,35	33,35	98,17	36,54	92,06	40,07	85,50	44,00	-	-
	12	7	107,70	33,72	101,39	36,90	95,06	40,47	88,40	44,46	-	-
	13	8	111,28	34,13	104,73	37,36	97,92	40,97	91,14	44,93	-	-
	14	9	114,68	34,55	107,89	37,82	101,08	41,48	94,04	45,34	-	-
	15	10	118,14	34,97	111,36	38,30	104,27	41,89	96,79	45,86	-	-
	16	11	121,67	35,40	114,65	38,77	107,31	42,41	100,04	46,29	-	-
	17	12	125,26	35,83	117,99	39,25	110,65	42,95	102,90	46,83	-	-
LCC 115 CL	10	5	115,06	27,72	105,40	33,28	99,00	36,90	92,61	40,98	85,80	45,35
	11	6	119,35	32,19	108,88	38,05	102,49	41,71	95,72	45,77	-	-
	12	7	118,71	35,02	112,45	38,44	105,82	42,14	98,81	46,23	-	-
	13	8	122,54	35,42	116,11	38,83	109,14	42,62	101,98	46,71	-	-
	14	9	126,43	35,83	119,75	39,27	112,89	43,07	105,46	47,19	-	-
	15	10	130,60	36,28	123,47	39,72	116,46	43,51	108,77	47,67	-	-
	16	11	134,75	36,65	127,65	40,13	120,11	43,95	112,40	48,57	-	-
	17	12	138,77	37,11	131,42	40,63	123,71	44,45	115,72	48,73	-	-
LCC 130 CL	10	5	128,44	33,91	121,80	37,73	114,54	41,86	106,87	46,33	99,00	51,01
	11	6	132,61	38,75	125,70	42,61	118,28	46,73	110,57	51,26	-	-
	12	7	136,99	39,17	129,82	43,07	122,12	47,22	114,13	51,80	-	-
	13	8	141,30	39,70	134,14	43,64	126,23	47,79	117,77	52,35	-	-
	14	9	145,81	40,17	138,47	44,10	130,16	48,35	121,37	52,97	-	-
	15	10	150,74	40,66	142,67	44,67	134,16	48,92	125,33	53,61	-	-
	16	11	155,33	41,19	147,18	45,14	138,54	49,50	129,22	54,17	-	-
	17	12	159,99	41,72	151,51	45,72	142,68	50,09	133,60	54,79	-	-
LCC 145 CL	10	5	147,00	44,43	138,94	48,64	130,39	53,32	121,40	58,59	112,40	63,82
	11	6	151,63	48,06	143,04	52,38	134,57	57,07	125,42	62,32	-	-
	12	7	156,44	48,67	147,74	52,98	138,70	57,71	129,21	62,99	-	-
	13	8	161,05	49,27	152,21	53,58	142,85	58,36	133,28	63,68	-	-
	14	9	165,86	49,88	156,66	54,24	147,01	59,02	137,27	64,35	-	-
	15	10	170,64	50,50	161,54	54,92	151,58	59,77	141,21	65,02	-	-
	16	11	176,07	51,14	166,15	55,60	155,97	60,44	145,48	65,77	-	-
	17	12	181,04	51,77	170,97	56,23	160,62	61,20	149,84	66,37	-	-
LCC 160 CL	10	5	158,42	50,69	149,18	58,45	139,55	60,65	129,91	66,65	120,00	72,46
	11	6	161,10	54,40	153,82	59,19	143,82	64,56	133,61	70,49	-	-
	12	7	168,03	55,15	158,32	59,86	148,21	65,22	137,86	71,15	-	-
	13	8	172,90	55,83	162,93	60,54	152,59	66,05	141,47	71,96	-	-
	14	9	178,05	56,54	167,78	61,31	156,75	66,88	146,03	72,70	-	-
	15	10	183,04	57,25	172,39	62,08	161,03	67,72	150,16	73,42	-	-
	16	11	188,08	57,97	177,36	62,90	165,69	68,58	154,22	74,22	-	-
	17	12	193,18	58,70	182,07	63,73	170,50	69,44	158,75	74,94	-	-

10 LCC HS COOLING CAPACITY

Tw₁ Water inlet temperature
 Tw₂ Water outlet temperature
 Tbs₁ Dry bulb air temperature
 PF Cooling capacity
 PA Power input

LCC	Tbs ₁		25		30		35		40		45	
	Tw ₁	Tw ₂	PF	PA	PF	PA	PF	PA	PF	PA	PF	PA
	°C	°C	kW	kW	kW	kW	kW	kW	kW	kW	kW	kW
LCC 050 HS	10	5	50,35	16,40	47,31	18,63	44,13	19,84	41,02	21,89	37,66	24,10
	11	6	51,92	16,55	48,87	18,15	45,63	19,98	42,35	22,20	-	-
	12	7	53,61	16,66	50,45	18,28	47,21	20,11	43,69	22,20	-	-
	13	8	55,33	16,76	52,18	18,39	48,71	20,25	45,17	22,29	-	-
	14	9	56,99	16,91	53,83	18,51	50,24	20,38	46,56	22,50	-	-
	15	10	58,91	17,01	55,41	18,68	51,92	20,51	48,09	22,58	-	-
	16	11	60,64	17,16	57,12	18,79	53,50	20,64	49,53	22,78	-	-
LCC 060 HS	10	5	57,86	19,39	54,47	21,27	51,06	23,40	47,41	25,82	43,62	28,38
	11	6	59,90	19,53	56,39	21,43	52,73	23,58	48,94	26,01	-	-
	12	7	61,75	19,72	58,22	21,59	54,32	23,82	50,62	26,21	-	-
	13	8	63,63	19,91	59,97	21,80	56,15	23,93	52,09	26,46	-	-
	14	9	65,65	20,05	61,90	22,01	57,93	24,17	53,82	26,57	-	-
	15	10	67,72	20,19	63,84	22,17	59,61	24,41	55,47	26,81	-	-
	16	11	69,87	20,39	65,81	22,33	61,57	24,58	57,15	26,28	-	-
LCC 070 HS	10	5	66,96	21,28	63,19	23,36	59,38	25,73	55,37	28,40	51,25	31,29
	11	6	69,17	21,45	65,22	23,57	61,32	25,94	57,17	28,62	-	-
	12	7	71,49	21,67	67,50	23,76	63,25	26,18	59,08	28,89	-	-
	13	8	73,80	21,84	69,61	23,97	65,28	26,39	60,95	29,11	-	-
	14	9	76,04	22,06	71,77	24,19	67,50	26,59	62,86	29,34	-	-
	15	10	78,45	22,23	74,14	24,41	69,55	26,84	64,72	29,61	-	-
	16	11	80,79	22,46	76,39	24,63	71,63	27,08	66,85	29,83	-	-
LCC 080 HS	10	5	71,55	25,12	67,31	27,58	62,64	30,34	57,81	33,41	53,08	36,50
	11	6	73,77	25,38	69,43	27,83	64,66	30,59	59,79	33,69	-	-
	12	7	76,19	25,64	71,52	28,13	66,73	30,92	61,68	33,95	-	-
	13	8	78,62	25,84	73,79	28,35	68,83	31,18	63,59	34,30	-	-
	14	9	81,08	26,14	76,13	28,65	70,88	31,48	65,53	34,57	-	-
	15	10	83,53	26,38	78,34	28,96	73,13	31,78	67,51	34,83	-	-
	16	11	85,96	26,65	80,75	29,26	75,16	32,12	69,51	35,18	-	-
LCC 090 HS	10	5	90,71	29,62	85,52	32,28	80,07	35,27	74,46	38,58	68,63	42,18
	11	6	93,70	29,86	88,25	32,59	82,68	35,58	76,88	38,92	-	-
	12	7	96,61	30,18	91,12	32,87	85,55	35,89	79,52	39,27	-	-
	13	8	99,95	30,43	94,26	33,15	88,28	36,20	82,04	39,61	-	-
	14	9	102,98	30,76	97,08	33,51	90,98	36,56	84,79	39,96	-	-
	15	10	106,23	31,01	100,13	33,80	93,72	36,92	87,31	40,36	-	-
	16	11	109,37	31,34	103,29	34,17	96,83	37,25	89,87	40,77	-	-
	17	112,58	31,67	106,46	34,46	99,59	37,66	92,80	41,12	-	-	

10 LCC HS COOLING CAPACITY

- Tw₁ Water inlet temperature
- Tw₂ Water outlet temperature
- Tbs₁ Dry bulb air temperature
- PF Cooling capacity
- PA Power input

LCC	Tbs ₁		25		30		35		40		45	
	Tw ₁	Tw ₂	PF	PA	PF	PA	PF	PA	PF	PA	PF	PA
	°C	°C	kW	kW	kW	kW	kW	kW	kW	kW	kW	kW
LCC 105 HS	10	5	101,07	34,76	95,19	37,86	89,08	41,35	82,79	45,34	76,42	49,27
	11	6	104,35	35,12	98,17	38,31	92,06	41,84	85,50	45,77	-	-
	12	7	107,70	35,49	101,39	38,67	95,06	42,24	88,40	46,23	-	-
	13	8	111,28	35,90	104,73	39,13	97,92	42,74	91,14	46,70	-	-
	14	9	114,68	36,32	107,89	39,59	101,08	43,25	94,04	47,11	-	-
	15	10	118,14	36,74	111,36	40,07	104,27	43,66	96,79	47,63	-	-
	16	11	121,67	37,17	114,65	40,54	107,31	44,18	100,04	48,06	-	-
LCC 115 HS	10	5	115,06	36,48	105,40	42,04	99,00	45,66	92,61	49,74	85,80	54,11
	11	6	119,35	36,57	108,88	42,43	102,49	46,09	95,72	50,15	-	-
	12	7	118,71	39,40	112,45	42,82	105,82	46,52	98,81	50,61	-	-
	13	8	122,54	39,80	116,11	43,21	109,14	47,00	101,98	51,09	-	-
	14	9	126,43	40,21	119,75	43,65	112,89	47,45	105,46	51,57	-	-
	15	10	130,60	40,66	123,47	44,10	116,46	47,89	108,77	52,05	-	-
	16	11	134,75	41,03	127,65	44,51	120,11	48,33	112,40	52,95	-	-
LCC 130 HS	10	5	128,44	42,67	121,80	46,49	114,54	50,62	106,87	55,09	99,00	59,77
	11	6	132,61	43,13	125,70	46,99	118,28	51,11	110,57	55,64	-	-
	12	7	136,99	43,55	129,82	47,45	122,12	51,60	114,13	56,18	-	-
	13	8	141,30	44,08	134,14	48,02	126,23	52,17	117,77	56,73	-	-
	14	9	145,81	44,55	138,47	48,48	130,16	52,73	121,37	57,35	-	-
	15	10	150,74	45,04	142,67	49,05	134,16	53,30	125,33	57,99	-	-
	16	11	155,33	45,57	147,18	49,52	138,54	53,88	129,22	58,55	-	-
LCC 145 HS	10	5	147,00	50,63	138,94	54,84	130,39	59,52	121,40	64,79	112,40	70,02
	11	6	151,63	51,16	143,04	55,48	134,57	60,17	125,42	65,42	-	-
	12	7	156,44	51,77	147,74	56,08	138,70	60,81	129,21	66,09	-	-
	13	8	161,05	52,37	152,21	56,68	142,85	61,46	133,28	66,78	-	-
	14	9	165,86	52,98	156,66	57,34	147,01	62,12	137,27	67,45	-	-
	15	10	170,64	53,60	161,54	58,02	151,58	62,87	141,21	68,12	-	-
	16	11	176,07	54,24	166,15	58,70	155,97	63,54	145,48	68,87	-	-
LCC 160 HS	10	5	158,42	56,89	149,18	61,55	139,55	66,85	129,91	72,85	120,00	78,66
	11	6	161,10	57,50	153,82	62,29	143,82	67,66	133,61	73,59	-	-
	12	7	168,03	58,25	158,32	62,96	148,21	68,32	137,86	74,25	-	-
	13	8	172,90	58,93	162,93	63,64	152,59	69,15	141,47	75,06	-	-
	14	9	178,05	59,64	167,78	64,41	156,75	69,98	146,03	75,80	-	-
	15	10	183,04	60,35	172,39	65,18	161,03	70,82	150,16	76,52	-	-
	16	11	188,08	61,07	177,36	66,00	165,69	71,68	154,22	77,32	-	-
	17	193,18	61,80	182,07	66,83	170,50	72,54	158,75	78,04	-	-	

11 LCC HL COOLING CAPACITY

- Tw₁ Water inlet temperature
- Tw₂ Water outlet temperature
- Tbs₁ Dry bulb air temperature
- PF Cooling capacity
- PA Power input

LCC	Tbs ₁		25		30		35		40		45	
	Tw ₁	Tw ₂	PF	PA	PF	PA	PF	PA	PF	PA	PF	PA
	°C	°C	kW	kW	kW	kW	kW	kW	kW	kW	kW	kW
LCC 050 HL	10	5	50,35	14,54	47,31	16,77	44,13	17,98	41,02	20,03	37,66	22,24
	11	6	51,92	14,69	48,87	16,29	45,63	18,12	42,35	20,34	-	-
	12	7	53,61	14,80	50,45	16,42	47,21	18,25	43,69	20,34	-	-
	13	8	55,33	14,90	52,18	16,53	48,71	18,39	45,17	20,43	-	-
	14	9	56,99	15,05	53,83	16,65	50,24	18,52	46,56	20,64	-	-
	15	10	58,91	15,15	55,41	16,82	51,92	18,65	48,09	20,72	-	-
	16	11	60,64	15,30	57,12	16,93	53,50	18,78	49,53	20,92	-	-
LCC 060 HL	10	5	57,86	17,99	54,47	19,87	51,06	22,00	47,41	24,42	43,62	26,98
	11	6	59,90	18,13	56,39	20,03	52,73	22,18	48,94	24,61	-	-
	12	7	61,75	18,32	58,22	20,19	54,32	22,42	50,62	24,81	-	-
	13	8	63,63	18,51	59,97	20,40	56,15	22,53	52,09	25,06	-	-
	14	9	65,65	18,65	61,90	20,61	57,93	22,77	53,82	25,17	-	-
	15	10	67,72	18,79	63,84	20,77	59,61	23,01	55,47	25,41	-	-
	16	11	69,87	18,99	65,81	20,93	61,57	23,18	57,15	24,88	-	-
LCC 070 HL	10	5	66,96	20,08	63,19	22,16	59,38	24,53	55,37	27,20	51,25	30,09
	11	6	69,17	20,25	65,22	22,37	61,32	24,74	57,17	27,42	-	-
	12	7	71,49	20,47	67,50	22,56	63,25	24,98	59,08	27,69	-	-
	13	8	73,80	20,64	69,61	22,77	65,28	25,19	60,95	27,91	-	-
	14	9	76,04	20,86	71,77	22,99	67,50	25,39	62,86	28,14	-	-
	15	10	78,45	21,03	74,14	23,21	69,55	25,64	64,72	28,41	-	-
	16	11	80,79	21,26	76,39	23,43	71,63	25,88	66,85	28,63	-	-
LCC 080 HL	10	5	71,55	23,92	67,31	26,38	62,64	29,14	57,81	32,21	53,08	35,30
	11	6	73,77	25,38	69,43	27,83	64,66	30,59	59,79	33,69	-	-
	12	7	76,19	25,64	71,52	28,13	66,73	30,92	61,68	33,95	-	-
	13	8	78,62	25,84	73,79	28,35	68,83	31,18	63,59	34,30	-	-
	14	9	81,08	26,14	76,13	28,65	70,88	31,48	65,53	34,57	-	-
	15	10	83,53	26,38	78,34	28,96	73,13	31,78	67,51	34,83	-	-
	16	11	85,96	26,65	80,75	29,26	75,16	32,12	69,51	35,18	-	-
LCC 090 HL	10	5	90,71	27,85	85,52	30,51	80,07	33,50	74,46	36,81	68,63	40,41
	11	6	93,70	29,86	88,25	32,59	82,68	35,58	76,88	38,92	-	-
	12	7	96,61	30,18	91,12	32,87	85,55	35,89	76,52	39,27	-	-
	13	8	99,95	30,43	94,26	33,15	88,28	36,20	82,04	39,61	-	-
	14	9	102,98	30,76	97,08	33,51	90,98	36,56	84,79	39,96	-	-
	15	10	106,23	31,01	100,13	33,80	93,72	36,92	87,31	40,36	-	-
	16	11	109,37	31,34	103,29	34,17	96,83	37,25	89,87	40,77	-	-
	17	112,58	31,67	106,46	34,46	99,59	37,66	92,80	41,12	-	-	

11 LCC HL COOLING CAPACITY

- Tw₁ Water inlet temperature
- Tw₂ Water outlet temperature
- Tbs₁ Dry bulb air temperature
- PF Cooling capacity
- PA Power input

LCC	Tbs ₁		25		30		35		40		45	
	Tw ₁	Tw ₂	PF	PA	PF	PA	PF	PA	PF	PA	PF	PA
	°C	°C	kW	kW	kW	kW	kW	kW	kW	kW	kW	kW
LCC 105 HL	10	5	101,07	32,99	95,19	36,09	89,08	39,58	82,79	43,57	76,42	47,50
	11	6	104,35	35,12	98,17	38,31	92,06	41,84	85,50	45,77	-	-
	12	7	107,70	35,49	101,39	38,67	95,06	42,24	88,40	46,23	-	-
	13	8	111,28	35,90	104,73	39,13	97,92	42,74	91,14	46,70	-	-
	14	9	114,68	36,32	107,89	39,59	101,08	43,25	94,04	47,11	-	-
	15	10	118,14	36,74	111,36	40,07	104,27	43,66	96,79	47,63	-	-
	16	11	121,67	37,17	114,65	40,54	107,31	44,18	100,04	48,06	-	-
LCC 115 HL	10	5	115,06	32,10	105,40	37,66	99,00	41,28	92,61	45,36	85,80	49,73
	11	6	119,35	36,57	108,88	42,43	102,49	46,09	95,72	50,15	-	-
	12	7	118,71	39,40	112,45	42,82	105,82	46,52	98,81	50,61	-	-
	13	8	122,54	39,80	116,11	43,21	109,14	47,00	101,98	51,09	-	-
	14	9	126,43	40,21	119,75	43,65	112,89	47,45	105,46	51,57	-	-
	15	10	130,60	40,66	123,47	44,10	116,46	47,89	108,77	52,05	-	-
	16	11	134,75	41,03	127,65	44,51	120,11	48,33	112,40	52,95	-	-
LCC 130 HL	10	5	128,44	38,29	121,80	42,11	114,54	46,24	106,87	50,71	99,00	55,39
	11	6	132,61	43,13	125,70	46,99	118,28	51,11	110,57	55,64	-	-
	12	7	136,99	43,55	129,82	47,45	122,12	51,60	114,13	56,18	-	-
	13	8	141,30	44,08	134,14	48,02	126,23	52,17	117,77	56,73	-	-
	14	9	145,81	44,55	138,47	48,48	130,16	52,73	121,37	57,35	-	-
	15	10	150,74	45,04	142,67	49,05	134,16	53,30	125,33	57,99	-	-
	16	11	155,33	45,57	147,18	49,52	138,54	53,88	129,22	58,55	-	-
LCC 145 HL	10	5	147,00	47,53	138,94	51,74	130,39	56,42	121,40	61,69	112,40	66,92
	11	6	151,63	51,16	143,04	55,48	134,57	60,17	125,42	65,42	-	-
	12	7	156,44	51,77	147,74	56,08	138,70	60,81	129,21	66,09	-	-
	13	8	161,05	52,37	152,21	56,68	142,85	61,46	133,28	66,78	-	-
	14	9	165,86	52,98	156,66	57,34	147,01	62,12	137,27	67,45	-	-
	15	10	170,64	53,60	161,54	58,02	151,58	62,87	141,21	68,12	-	-
	16	11	176,07	54,24	166,15	58,70	155,97	63,54	145,48	68,87	-	-
LCC 160 HL	10	5	158,42	53,79	149,18	61,55	139,55	63,75	129,91	69,75	120,00	75,56
	11	6	161,10	57,50	153,82	62,29	143,82	67,66	133,61	73,59	-	-
	12	7	168,03	58,25	158,32	62,96	148,21	68,32	137,86	74,25	-	-
	13	8	172,90	58,93	162,93	63,64	152,59	69,15	141,47	75,06	-	-
	14	9	178,05	59,64	167,78	64,41	156,75	69,98	146,03	75,80	-	-
	15	10	183,04	60,35	172,39	65,18	161,03	70,82	150,16	76,52	-	-
	16	11	188,08	61,07	177,36	66,00	165,69	71,68	154,22	77,32	-	-
	17	193,18	61,80	182,07	66,83	170,50	72,54	158,75	78,04	-	-	

12 LCC H HEATING CAPACITY

Tw₁ Water inlet temperature
 Tw₂ Water outlet temperature
 Tbs₁ Dry bulb air temperature

PT Heating capacity
 PA Power input

In the heat pump operation (heating mode), the actual heating capacities of units may be lower than the values shown in the table, due to defrosting cycles..

LCC	Tbs ₁ /RH		-10°C / 90%		0°C / 90%		7°C / 87%		10°C / 70%		15°C / 60%	
	Tw ₁	Tw ₂	PT	PA	PT	PA	PT	PA	PT	PA	PT	PA
	°C	°C	kW	kW	kW	kW	kW	kW	kW	kW	kW	kW
LCC 050 HS	30	35	45,27	18,21	46,03	18,34	55,62	18,56	60,37	18,62	70,06	18,87
	35	40	44,82	19,69	45,70	19,93	54,81	20,18	59,01	20,34	67,57	20,43
	40	45	44,24	21,55	45,19	21,75	54,00	22,03	58,06	22,09	66,21	22,20
LCC 050 HL	30	35	45,27	16,35	46,03	16,48	55,62	16,70	60,37	16,76	70,06	17,01
	35	40	44,82	17,83	45,70	18,07	54,81	18,32	59,01	18,48	67,57	18,57
	40	45	44,24	19,69	45,19	19,89	54,00	20,17	58,06	20,23	66,21	20,34
LCC 060 HS	30	35	52,25	20,25	52,30	20,34	63,20	20,64	68,28	20,78	78,49	21,00
	35	40	51,82	22,04	52,03	22,15	62,38	22,48	67,23	22,63	77,00	22,87
	40	45	51,29	24,07	51,76	24,26	61,60	24,57	65,94	24,74	76,43	24,99
LCC 060 HL	30	35	52,25	18,85	52,30	18,94	63,20	19,24	68,28	19,38	78,49	19,60
	35	40	51,82	20,64	52,03	20,75	62,38	21,08	67,23	21,23	77,00	21,47
	40	45	51,29	22,67	51,76	22,86	61,60	23,17	65,94	23,34	76,43	23,59
LCC 070 HS	30	35	59,89	22,58	61,39	22,74	74,34	23,11	81,01	23,24	93,67	23,71
	35	40	57,61	24,63	60,81	24,81	73,06	25,22	79,32	25,48	92,01	25,75
	40	45	57,05	26,96	60,29	27,16	72,20	27,61	78,54	28,59	90,35	28,05
LCC 070 HL	30	35	59,89	21,38	61,39	21,54	74,34	21,91	81,01	22,04	93,67	22,51
	35	40	57,61	23,43	60,81	23,61	73,06	24,02	79,32	24,28	92,01	24,55
	40	45	57,05	25,76	60,29	25,96	72,20	26,41	78,54	27,39	90,35	26,85
LCC 080 HS	30	35	67,51	25,10	67,92	25,36	82,25	25,84	89,53	26,12	105,07	26,41
	35	40	66,86	27,46	67,30	27,65	81,04	28,19	88,12	28,37	102,46	28,83
	40	45	65,94	30,03	66,75	30,24	79,80	30,83	86,43	34,75	100,58	31,56
LCC 080 HL	30	35	67,51	23,90	67,92	24,16	82,25	24,64	89,53	24,92	105,07	25,21
	35	40	66,86	26,26	67,30	26,45	81,04	26,99	88,12	27,17	102,46	27,63
	40	45	65,94	28,83	66,75	29,04	79,80	29,63	86,43	33,55	100,58	36,65
LCC 090 HS	30	35	80,58	30,96	82,02	31,10	99,43	31,75	108,42	32,08	125,75	32,71
	35	40	79,37	33,56	81,64	33,68	98,93	34,50	106,32	34,77	123,25	35,40
	40	45	75,78	36,28	81,05	36,68	97,20	37,51	105,00	39,22	120,67	38,42
LCC 090 HL	30	35	80,58	29,19	82,02	29,33	99,43	29,98	108,42	30,31	125,75	30,94
	35	40	79,37	31,79	81,64	31,91	98,93	32,73	106,32	33,00	123,25	33,63
	40	45	75,78	34,51	81,05	34,91	97,20	35,74	105,00	37,45	120,67	36,65
LCC 105 HS	30	35	92,14	35,04	92,05	35,03	111,63	35,86	121,36	36,22	141,41	37,26
	35	40	90,45	37,93	91,00	37,96	110,00	38,89	119,17	39,46	138,15	40,25
	40	45	88,90	41,06	90,29	41,26	108,00	42,31	117,85	42,77	135,50	43,61
LCC 105 HL	30	35	92,14	33,27	92,05	33,26	111,63	34,09	121,36	34,45	141,41	35,49
	35	40	90,45	36,16	91,00	36,19	110,00	37,12	119,17	37,69	138,15	38,48
	40	45	88,90	39,29	90,29	39,49	108,00	40,54	117,85	41,00	135,50	41,84
LCC 115 HS	30	35	92,90	41,73	111,18	42,50	133,38	43,54	144,69	46,53	166,18	48,59
	35	40	91,63	44,87	109,77	45,77	131,10	46,93	144,69	46,53	166,18	48,59
	40	45	90,33	48,26	108,36	49,40	129,00	50,67	140,23	51,33	162,49	52,48
LCC 115 HL	30	35	92,90	38,63	111,18	39,40	133,38	40,44	144,69	43,43	166,18	42,04
	35	40	91,63	41,77	109,77	42,67	131,10	43,83	144,69	43,43	166,18	45,49
	40	45	90,33	45,16	108,36	46,30	129,00	47,57	140,23	48,23	162,49	49,38
LCC 130 HS	30	35	120,63	45,48	120,64	45,71	142,72	46,76	154,71	53,39	182,48	48,78
	35	40	108,88	48,58	119,31	49,40	140,49	50,75	154,71	53,39	178,78	52,74
	40	45	106,96	52,40	118,96	53,45	129,00	54,94	154,71	53,39	175,66	56,82
LCC 130 HL	30	35	120,63	41,10	120,64	41,33	142,72	42,38	154,71	49,01	182,48	44,40
	35	40	108,88	44,20	119,31	45,02	140,49	46,37	154,71	49,01	178,78	48,36
	40	45	106,96	48,02	118,96	49,07	129,00	50,56	154,71	49,01	175,66	52,44
LCC 145 HS	30	35	123,32	48,48	134,10	49,52	159,43	50,97	173,18	51,71	202,87	53,09
	35	40	122,12	52,51	132,52	53,49	157,41	55,05	170,77	55,73	199,41	57,32
	40	45	112,71	56,54	131,13	57,90	155,00	59,55	166,99	66,91	195,05	61,97
LCC 145 HL	30	35	123,32	44,10	134,10	45,14	159,43	46,59	173,18	47,33	202,87	48,71
	35	40	122,12	48,13	132,52	49,11	157,41	50,67	170,77	51,35	199,41	52,94
	40	45	112,71	52,16	131,13	53,52	155,00	55,17	166,99	62,53	195,05	57,59
LCC 160 HS	30	35	124,58	52,01	144,10	53,82	172,97	55,53	187,59	56,48	221,33	58,49
	35	40	123,81	56,82	142,37	58,16	170,31	60,17	184,61	60,93	216,24	62,80
	40	45	116,89	61,33	141,07	63,32	168,00	64,89	181,42	65,95	211,93	67,63
LCC 160 HL	30	35	124,58	48,91	144,10	50,72	172,97	52,43	187,59	53,38	221,33	55,39
	35	40	123,81	53,72	142,37	55,06	170,31	57,07	184,61	57,83	216,24	59,70
	40	45	116,89	58,23	141,07	60,22	168,00	61,79	181,42	62,85	211,93	64,50

13 EVAPORATOR PRESSURE DROPS

The diagram shows the pressure drops on the water side (Δp_w) as a function of the water flow rate (Q_w), assuming an average water temperature of 10°C

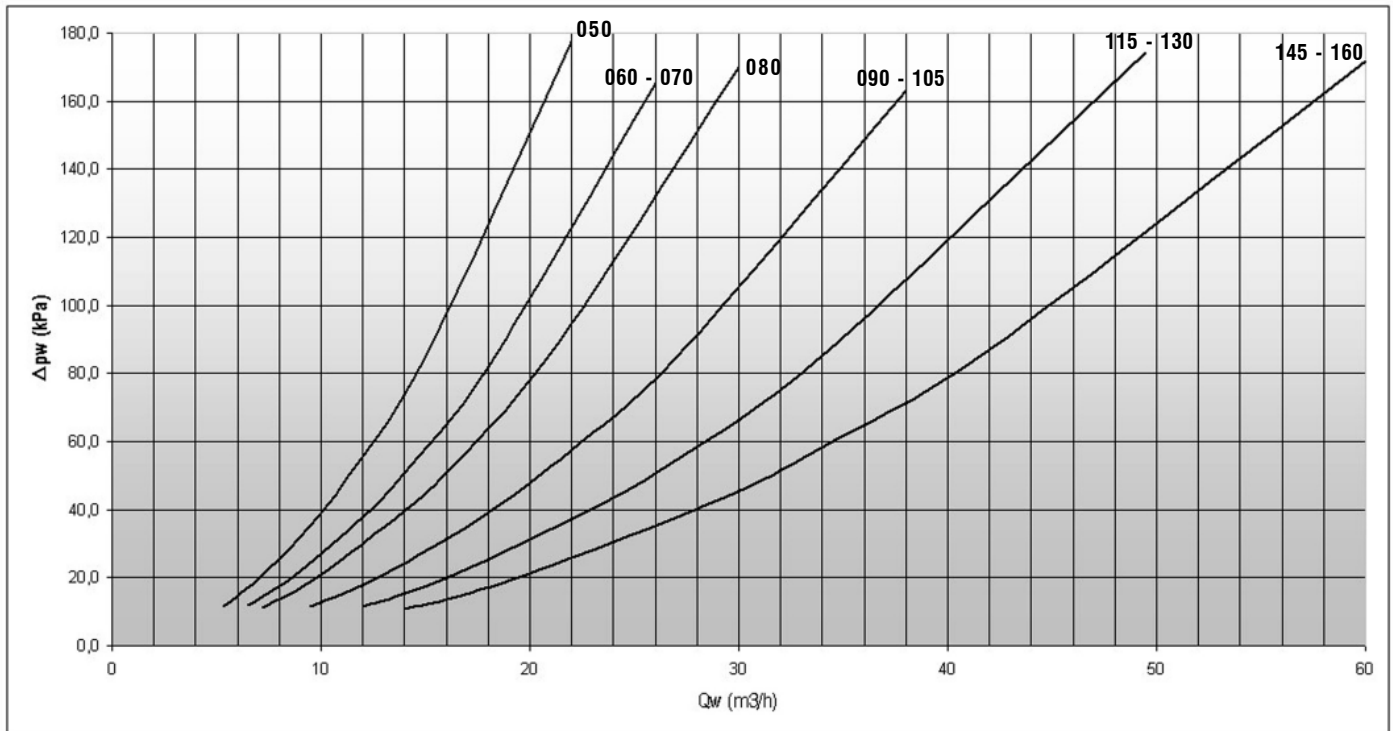

14 CALCULATION FACTORS

WATER TEMPERATURE DROP/RISE DIFFERENT THAN 5						
Water temperature drop/rise	3	4	5	6	7	8
Capacity correction factor	0,975	0,990	1,000	1,015	1,030	1,040
Power input correction factor	1,000	1,000	1,000	1,000	1,000	1,000
Water flow correction factor	1,630	1,240	1,000	0,850	0,740	0,650
Water pressure drop correction factor	2,640	1,530	1,000	0,720	0,540	0,420

OPERATION WITH ETHYLEN GLYCOL AND WATER SOLUTION					
Percentage of glycol	0%	10%	20%	30%	40%
Minimum water outlet temperature	5°C	2°C	-5°C	-10°C	-15°C
Mixture freezing temperature (°C)	0°C	-4°C	-14°C	-18°C	-24°C
Capacity correction factor	1,000	0,998	0,994	0,989	0,983
Water flow correction factor	1,000	1,047	1,094	1,140	1,199
Water pressure drop correction factor	1,000	1,157	1,352	1,585	1,860

OPERATION WITH PROPYLEN GLYCOL AND WATER SOLUTION					
Percentage of glycol	0%	10%	20%	30%	40%
Minimum water outlet temperature	5°C	2°C	-5°C	-10°C	-15°C
Mixture freezing temperature (°C)	0°C	-4°C	-14°C	-18°C	-24°C
Capacity correction factor	1,000	0,996	0,985	0,971	0,960
Water flow correction factor	1,000	1,022	1,043	1,070	1,098
Water pressure drop correction factor	1,000	1,111	1,307	1,532	1,777

FOULING FACTORS			
Fouling factors (m ² °C / W)	4,4 x 10 ⁻⁵	8,8 x 10 ⁻⁵	17,6 x 10 ⁻⁵
Capacity correction factor	1,000	0,970	0,940
Power input correction factor	1,000	0,990	0,980

15 WATER SYSTEM OPTIONS

LCC units may be equipped with 4 types of pumping systems, complete with expansion tank, and inertial storage reservoirs:

- single standard pump
- single uprated pump
- standard pump and back-up pump
- uprated pump and back-up pump.

In the case of pump systems including a back-up pump, the microprocessor controls the pumps in such a way as to equally divide the hours of operation, changing over the pumps in the event of a fault.

The water tank is located between the condenser coils and can be mounted together with all the other options available.

The figure illustrates the integrating-attenuating function of the storage reservoir, which clearly represents an advantage in that it enables the controllers of the indoor units connected to the system to more precisely control the ambient parameters.

If the reservoir is not used or is installed on the return line, every time a compressor switches on or off, the temperature will fluctuate by an amount equal to the total DT/n° of reduction steps: clearly the situation improves as the number of steps increases.

The diagrams below compare a situation with and without an inertial storage reservoir in a single-step system.

The attenuating effect provided by the storage reservoir is clearly evident, as is the impossibility of maintaining ambient parameters - especially relative humidity - with outlet temperature T_w , fluctuations of 7°C , as illustrated.

Set-point regulation of outlet temperature T_w with a multi-step system may be achieved by means of:

- an adjustment of the water flow rate and this is negative because it presupposes a reduction in the thermal load of all the interiors served and therefore users requiring a full flow lose control over temperature and humidity.
- hot gas bypass, which makes no sense from an energy standpoint since it results in a lower cooling capacity, the electrical input being equal.

The inertial storage reservoir thus represents the simplest and most energy-efficient solution for optimising the combined operation of the water chiller and indoor units.

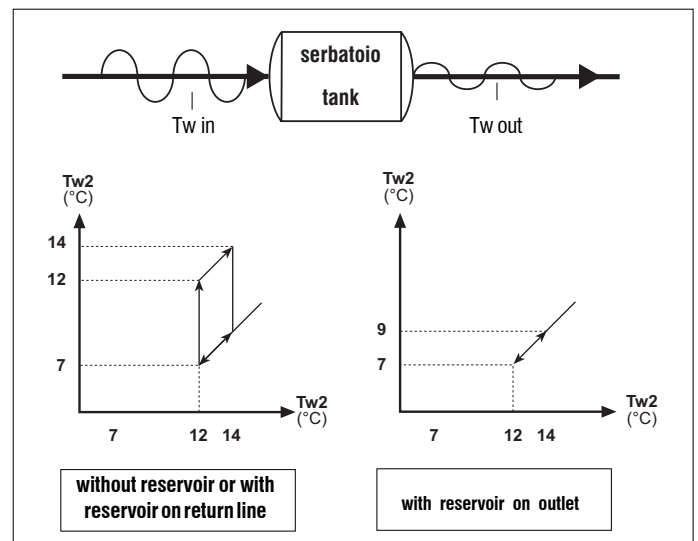

LCC		50	60	70	80	90	105	115	130	145	160
Inertial storage reservoir capacity	dm ³	340	340	340	340	340	340	340	340	340	340
Expansion tank	dm ³	8	8	8	8	12	12	25	25	25	25
Standard pump		A	B	B	B	C	C	C	C	D	D
Rated electrical output	kW	0,55	0,75	0,75	0,75	1,50	1,50	1,50	1,50	2,20	2,20
Operating current	A	1,7	2,3	2,3	2,3	4,3	4,3	4,3	4,3	5,3	5,3
Uprated pump		E	F	F	F	G	G	H	H	H	H
Rated electrical output	kW	1,5	2,2	2,2	2,2	3,0	3,0	4,0	4,0	4,0	4,0
Operating current	A	4,3	5,3	5,3	5,3	6,6	6,6	9,2	9,2	9,2	9,2

15 WATER SYSTEM OPTIONS

The diagram shows the hydraulic pumps head curves (standard and uprated), as a function of the water flow, to be installed on LCC units. In order to calculate the available head is necessary to deduct the water pressure drop from pump head.

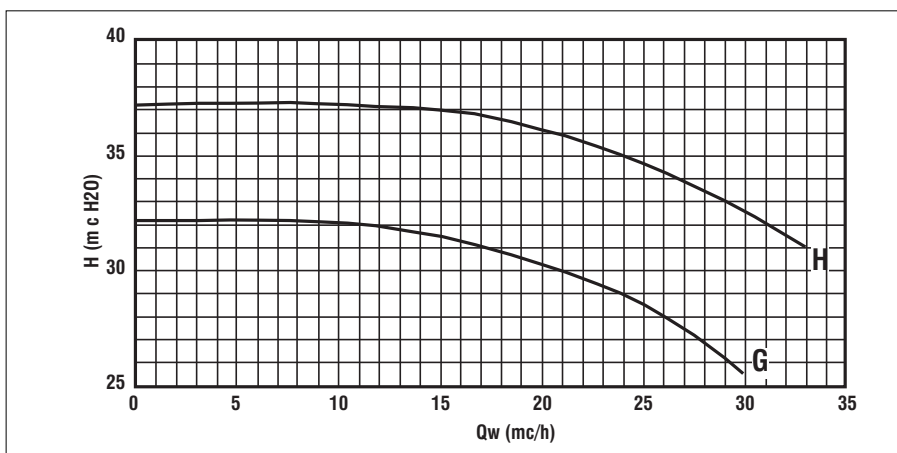
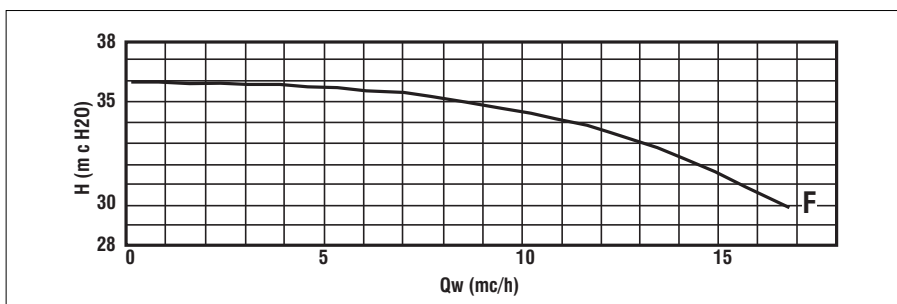
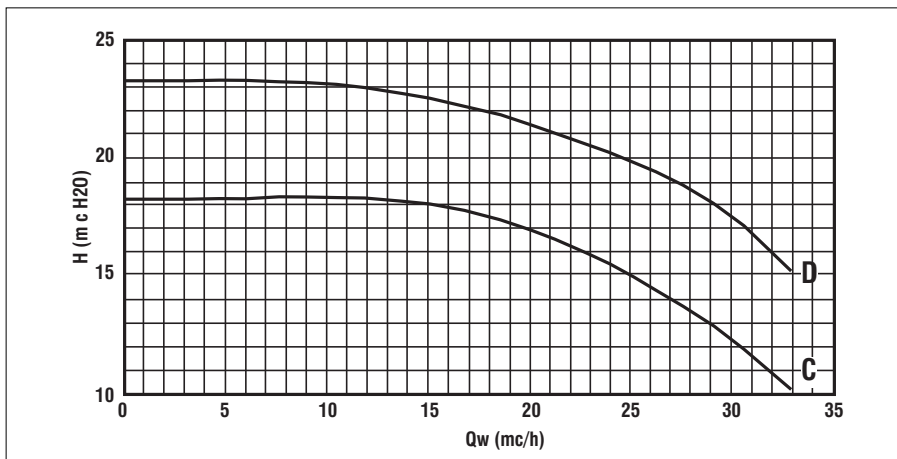
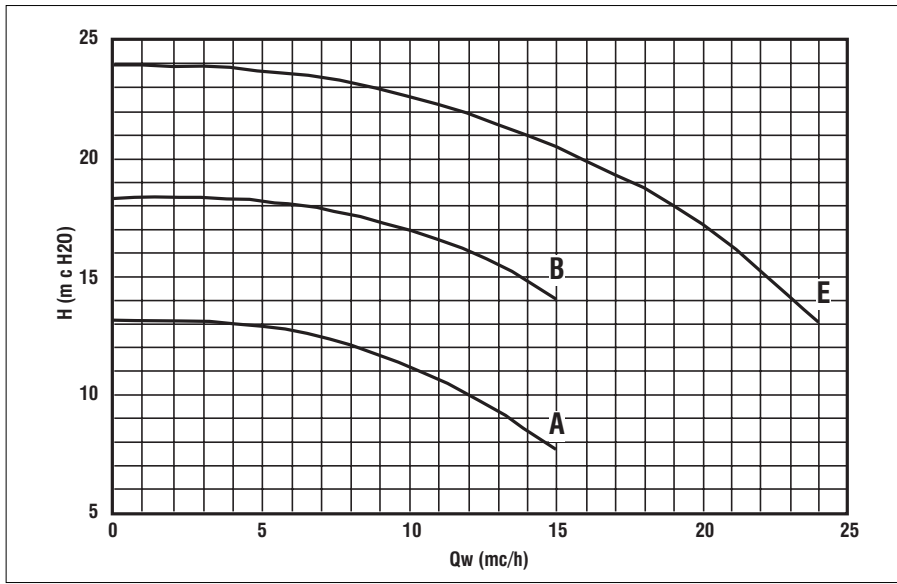

16 HEAT RECOVERY OPTIONS

PTR Heat recovery heating capacity
QWR Heat recovery water flow

In air-conditioning applications it is useful and often indispensable to have heat available for heating sanitary water or controlling post-heating in air-handling units where independent temperature and humidity control is required. All the units belonging to the LCC-C series can be equipped (on request) with a desuperheater for recovering 4.0% of the available heating capacity. All units equipped with a heat recovery kit have modulating condensation control as a standard feature.

To prevent unbalances from occurring in the cooling circuit in the event of start-ups with very low water temperatures at the recuperator inlet, the recovery system water circuit should be configured as shown in the figure. A low recuperator inlet water temperature would cause low condensation temperatures and thus an insufficient pressure differential on the expansion valve with the consequent risk of tripping the safety devices.

The bulb of the 3-way mixing valve is situated at the recuperator inlet and mixing the hot water produced with colder water from the inertial storage reservoir makes it possible to bring the system to optimal operating conditions in a few instants. Given that the demand for heat and the availability of heat do not coincide, since the latter is dependent on the compressors running, it is essential to install an inertial storage reservoir between the unit and the user.

The heat recovery capacity is tied to the delivered cooling capacity and therefore decreases proportionately in partial load situations: this aspect should be taken into account when choosing the size of the storage reservoir.

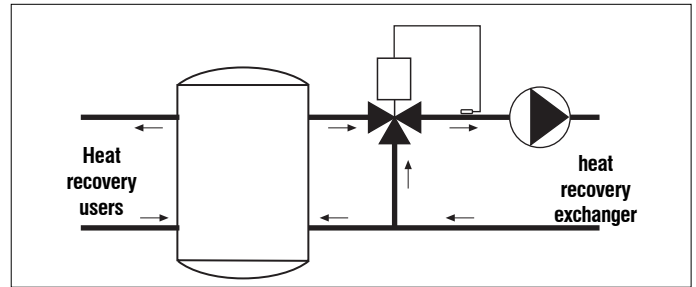

LCC	Tbs ₁		30		35		40		45	
	Tw ₁	Tw ₂	PTR	QWR	PTR	QWR	PTR	QWR	PTR	QWR
	°C	°C	kW	l/h	kW	l/h	kW	l/h	kW	l/h
LCC 050	35	40	11,5	2,0	14,3	2,5	16,8	2,9	19,6	3,4
	40	45	9,1	1,6	11,8	2,0	14,4	2,5	17,1	2,9
	45	50	6,5	1,1	9,3	1,6	11,9	2,1	14,7	2,5
LCC 060	35	40	13,2	2,3	16,4	2,8	19,3	3,3	22,5	3,9
	40	45	10,4	1,8	13,6	2,3	16,5	2,8	19,7	3,4
	45	50	7,5	1,3	10,7	1,8	13,7	2,4	16,9	2,9
LCC 070	35	40	15,3	2,6	19,1	3,3	22,5	3,9	26,2	4,5
	40	45	12,1	2,1	15,9	2,7	19,2	3,3	22,9	3,9
	45	50	8,7	1,5	12,5	2,2	16,0	2,7	19,6	3,4
LCC 080	35	40	16,2	2,8	20,2	3,5	23,7	4,1	27,7	4,8
	40	45	12,8	2,2	16,7	2,9	20,3	3,5	24,2	4,2
	45	50	9,2	1,6	13,2	2,3	16,9	2,9	20,7	3,6
LCC 090	35	40	20,8	3,6	25,9	4,4	30,4	5,2	35,5	6,1
	40	45	16,4	2,8	21,5	3,7	26,0	4,5	31,0	5,3
	45	50	11,8	2,0	16,9	2,9	21,6	3,7	26,6	4,6
LCC 105	35	40	23,1	4,0	28,7	4,9	33,8	5,8	39,4	6,8
	40	45	18,2	3,1	23,8	4,1	28,9	5,0	34,5	5,9
	45	50	13,1	2,3	18,8	3,2	24,0	4,1	29,5	5,1
LCC 115	35	40	25,7	4,4	32,0	5,5	37,6	6,5	43,9	7,6
	40	45	20,3	3,5	26,5	4,6	32,2	5,5	38,4	6,6
	45	50	14,6	2,5	20,9	3,6	26,7	4,6	32,9	5,7
LCC 130	35	40	29,6	5,1	36,9	6,4	43,4	7,5	50,7	8,7
	40	45	23,4	4,0	30,6	5,3	37,1	6,4	44,3	7,6
	45	50	16,8	2,9	24,1	4,2	30,9	5,3	37,9	6,5
LCC 145	35	40	33,6	5,8	41,9	7,2	49,3	8,5	57,5	9,9
	40	45	26,6	4,6	34,8	6,0	42,2	7,3	50,3	8,7
	45	50	19,1	3,3	27,4	4,7	35,0	6,0	43,1	7,4
LCC 160	35	40	35,9	6,2	44,8	7,7	52,6	9,1	61,5	10,6
	40	45	28,4	4,9	37,2	6,4	45,1	7,8	53,7	9,2
	45	50	20,4	3,5	29,3	5,0	37,4	6,4	46,0	7,9

16 HEAT RECOVERY OPTIONS

The diagram shows the pressure drops on the water side (Δp_w) as a function of the water flow rate (Q_w), assuming an average water temperature of 10°C

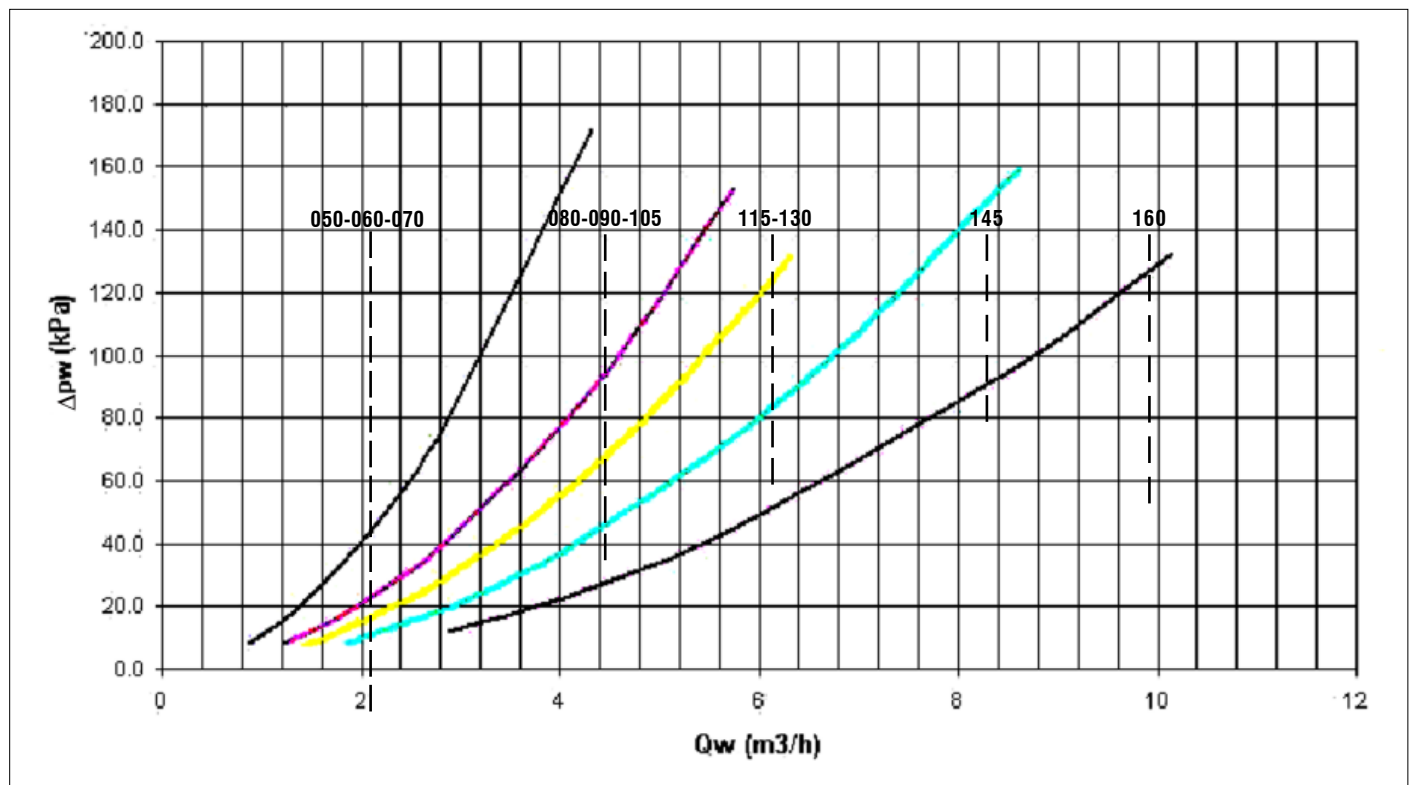

17 WATER CIRCUIT

When setting up the water circuit of the unit, it is advisable to follow the directions below and in any case comply with local or national regulations. Connect the pipes to the chiller using flexible couplings to prevent the transmission of vibrations and to compensate thermal expansions.

It is recommended to install the following components on the pipes:

- Temperature and pressure indicators for routine maintenance and monitoring of the unit.

Checking the pressure on the water side will enable you to verify whether the expansion tank is working efficiently and to promptly detect any water leaks within the equipment.

- Traps on incoming and outgoing pipes for temperature measurements, which can provide a direct reading of the operating temperatures.
- Regulating valves (gate valves) for isolating the unit from the water circuit.
- METAL MESH FILTER (INCOMING PIPES), WITH A MESH NOT TO EXCEED 1 MM, TO PROTECT THE EXCHANGER FROM SCALE OR IMPURITIES PRESENT IN THE PIPES.
- Air vent valves, to be placed at the highest points of the water circuit for the purpose of bleeding air.
(The internal pipes of the unit are fitted with small air vent valves for bleeding the unit itself: this operation may only be carried out when the unit is disconnected from the power supply).

- Drainage valve and, where necessary, a drainage tank for emptying out the equipment for maintenance purposes or when the unit is taken out of service at the end of the season.

(A 1" drainage valve is provided on the optional inertial storage reservoir: this operation may only be carried out when the unit is disconnected from the power supply).

It is of fundamental importance that the incoming water supply is hooked up to the connection marked "Water Inlet"

Otherwise the evaporator would be exposed to the risk of freezing since the antifreeze thermostat would not be able to perform its function; moreover the reverse cycle would not be respected in the cooling mode, resulting in additional risks of malfunctioning.

The dimensions and position of plumbing connections are shown in the dimension tables at the back of the manual.

The water circuit must be set up in such a way as to guarantee that the nominal flow rate of the water supplied to the evaporator remains constant (+/- 15%) in all operating conditions.

A standard feature of LCC units is a device for controlling the flow rate (flow switch or differential pressure switch) in the water circuit in the immediate vicinity of the evaporator.

Any tampering with said device will immediately invalidate the warranty.

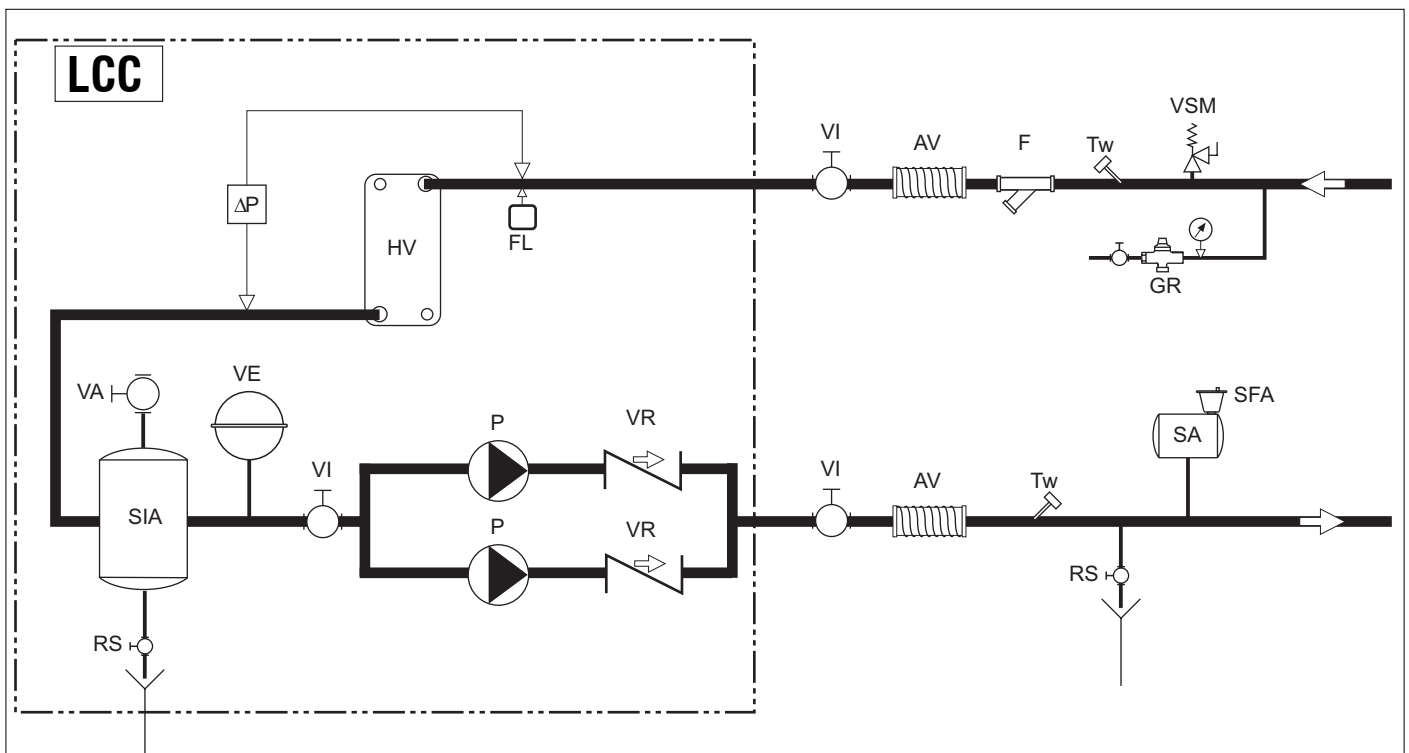

Δp	Differential pressure switch, water side
HV	Evaporator
FL	Flow switch
VE	Membrane expansion tank
VA	Manual air valve
SIA	Inertial water storage reservoir
RS	Emptying tap
VI	Regulating valve

P	Circulation pum
AV	Vibration damper
F	Metal filter
VSM	Spring-activated safety valve
GR	Filling unit
SA	Air separator
TW	Trap for reading water temperature

18 OPERATING LIMITS

Operating limits of LCC chillers in relation to the outlet water temperature and outdoor air temperature:

	Min.	Max.
Temperature of water leaving evaporator (°C)	5 (30)	12 (45)
Outdoor air temperature (°C)	-10	45

WATER FLOW TO EVAPORATOR

The nominal flow rate is based on a thermal differential of 5° C between inlet and outlet water, in relation to the cooling capacity provided at the nominal water (12/7 °C) and air (35°C) temperatures.

The maximum allowed flow rate is associated with a thermal differential of 3°C: higher flow rates, though admissible, cause pointless, high drops in pressure.

The minimum allowed flow rate is associated with a thermal differential of 8 °C or a minimum pressure drop of 10 kPa: lower flow rates cause a reduction in heat exchange coefficients and excessively low evaporation temperatures, which may trigger the safety devices and cause the unit to stop.

CHILLED WATER TEMPERATURES

The minimum temperature of the water leaving the evaporator is 5 °C: lower temperatures are possible, but for such applications the Manufacturer should be consulted at the time the order is placed.

The maximum temperature of the water entering the evaporator is 20 °C. To allow higher temperatures specific equipment solutions must be adopted (split circuits, three-way valves, bypasses, buffer tanks): contact the manufacturer.

OUTDOOR AIR TEMPERATURE

The units are designed and built to work with outdoor temperatures ranging from -10 (with compulsory condensation control) to +45°C. Contact the Manufacturer in the event of outdoor temperatures beyond this range.

OPERATION WITH WATER AT LOW TEMPERATURES

The standard units are not designed to work with chilled water temperatures below 5 °C at the evaporator outlet. In order to work below this limit, the unit requires specific technical adjustments: in such cases contact the Manufacturer.

FREE-COOLING VERSIONS LCC (FS-FL)

Free cooling units are designed for cooling operation only and cannot be used on heat pumps models. Due to their specific field of application these units feature a standard condensation pressure control device and an ADVANCED type microprocessor control device.

The following figure shows the standard field of application of free cooling units.

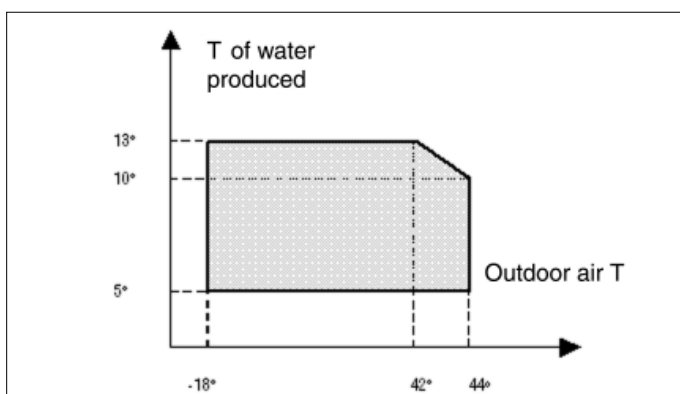

The lower limit is due to the freezing temperature of glycol solution containing 30% glycol (percentage in weight) which represents the maximum value admitted for the seals of pumps used. Special ceramic seals for pumps are available upon request for applications with T lower than the limit specified (solutions containing up to 50% glycol, in weight)

Minimum temperature of water produced °C	5	2	-1	-5	-10
Percentage of ethylene glycol (in weight) %	0 %	10%	15%	25%	30%
Freezing temperature of mixture °C	0	-4	-8	-14	-18

Free cooling units are supplied with heating elements for compressor oil sump. The diagram above illustrates a specific property [Charles' Law] of gases, which are more soluble in liquids as the pressure increases but less soluble as the temperature increases: if the oil in the sump is held at a constant pressure, an increase in temperature will significantly reduce the amount of refrigerant dissolved in it, thus ensuring that the lubricating function desired is maintained. In case of inadequate heating of the crankcase, insufficient lubrication may occur particularly after stoppage. Due to the suction action of compressor the oil sump pressure drops drastically, thus causing the evaporation of refrigerant previously dissolved in the oil. If heating elements were not installed, two problems would occur:

- > Oil dilution and thus insufficient lubrication
- > Migration of oil to the cooling circuit due to refrigerant entrainment.

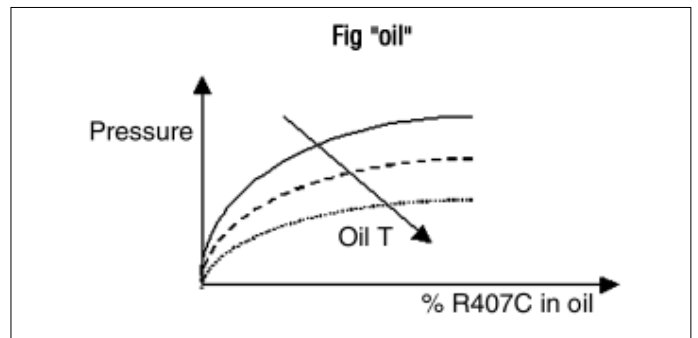

The use of heating elements is particularly important especially at first start-up. In this connection it is recommended that they are switched on at least 12 hours before the compressors are started.

If the outdoor air T drops drastically, the water T of the equipment is controlled through the fan modulating action and in case of strong prevalent winds through the closing of the 3-way valve. The joint modulating action of the 3-way valve is available only on request for special cases.

FREE COOLING WATER CIRCUIT VERSIONS:

Beside the above features, the free cooling versions are provided with a 3-way ON-OFF valve that deviates the flow to the free cooling coils upstream from the condenser coils within the air flow system. The valve activation is controlled by the microprocessor (ADVANCED type provided) that determines the difference between the set point T of the water (T1) returning from the system and the outdoor air T (T2). [as shown in the picture]

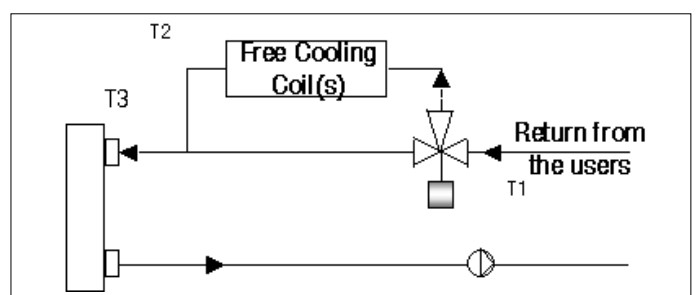

18 OPERATING LIMITS

The probe provided at evaporator inlet (T3) then controls the compressors' start to integrate their action, in case the free cooling performance is not sufficient to meet the indoor heat requirements. T1 and T3 are constantly monitored by the microprocessor installed on the unit in order to detect any fault of the free cooling 3-way valve. If T1 and T3 are the same in case of free cooling operation conditions, i.e. with changed over valve, it means that the valve is blocked. In case of free cooling fault conditions, it is possible to generate an alarm or to force the stopping of the unit.

In the LCC FS-FL models the option of a buffer tank is not available since the double finned coil, valve and pipes do not leave sufficient room for a tank. However, a single or double uprated pump is available as an option. The 3-way valve may also be manually positioned in case of faults in servomotor operation. The figure below shows the positioning of the 3-way valve, which can be accessed both from the front of the machine by opening the microprocessor door and removing the lower right panel (fig.a) and from the right side of the unit by removing the right-hand side covering panel (fig.b).

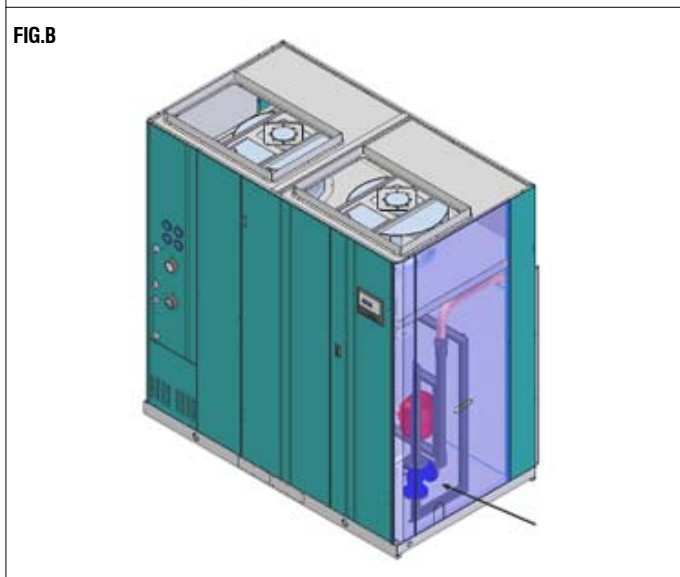

The free cooling units permit high energy saving when outdoor temperature is lower than the circulating fluid temperature (process industry, close control applications, information technology industry in general, congress halls, etc.) Free cooling circuit performance depends on the difference between outdoor air T and circulating water temperature, as illustrated in Fig. C.

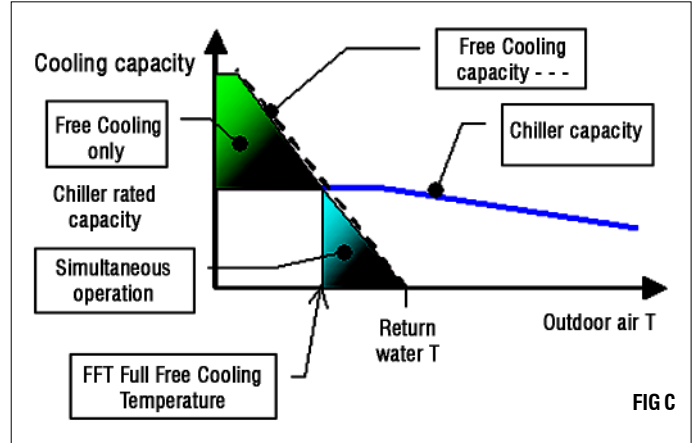

When outdoor air T2 falls below T1 of water returning from the system, heat exchange may occur, thus starting the free cooling unit with possible integration by one or more steps of mechanical cooling operation. In this phase it is particularly important to have the maximum air capacity in order to maximise the free-cooling condenser coil capacity and at the same time effectively control the condensation pressure.

Condensing coils feature a special capacity controlled circuit that reduces the heat exchange thus permitting the unit to operate at full air flow rate (fig. D).

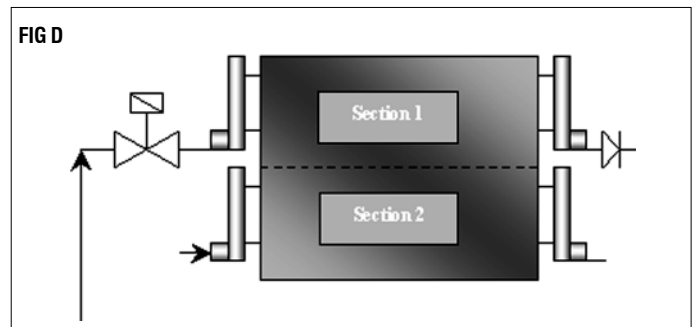

Both sections of the coil are normally operational in mechanical cooling mode only. When the free cooling mode is activated, i.e. when outdoor air T2 is lower than $(T1 - \Delta T)^\circ\text{C}$, and mechanical cooling operation is requested at the same time (integration), section 1 is cut off and ventilation can be forced at maximum rate, though maintaining an excellent control of condensation pressure.

In case of total free cooling mode, cooling capacity is modulated by adjusting the fan speed in order to maintain a constant water outgoing T.

In order to prevent the 3-way valve from blocking, it is automatically changed over up to 30% every 140 hours of operation while chiller is maintained in operation.

19 ELECTRICAL DATA

LCC		50	60	70	80	90	105	115	130	145	160
Power supply	V-f-Hz	400 - 3 - 50 + N									
Maximum input power	kW	26,38	30,42	33,15	38,36	44,76	51,85	58,70	64,36	73,08	81,72
Maximum current absorption	A	65	69	73	79	98	113	142	160	178	192
Starting current	A	163	171	190	214	269	291	346	378	415	446
Number of axial fans	n°	2	2	2	2	3	3	3	3	3	3
Standard version rated power of fan motor	kW	4,6	4,6	4,6	4,6	6,9	6,9	11,7	11,7	11,7	11,7
Standard version rated current of fan motor	A	8,5	8,5	8,5	8,5	12,8	12,8	19,2	19,2	19,2	19,2
Low noise version rated power of fan motor	kW	2,74	3,20	3,40	3,40	5,13	5,13	7,32	7,32	8,60	8,60
Low noise version rated current of fan motor	A	8,06	9,41	10,00	10,00	15,10	15,10	21,50	21,50	25,30	25,30
Rated power of standard pump motor	kW	0,55	0,75	0,75	0,75	1,50	1,50	1,50	1,50	2,20	2,20
Rated current of standard pump motor	A	1,7	2,3	2,3	2,3	4,3	4,3	4,3	4,3	5,3	5,3
Rated power of uprated pump motor	kW	1,5	2,2	2,2	2,2	3,0	3,0	4,0	4,0	4,0	4,0
Rated current of uprated pump motor	A	4,3	5,3	5,3	5,3	6,6	6,6	9,6	9,6	9,6	9,6
Auxiliary power supply	V-f-Hz	220 - 1 - 50									

- The maximum input power is the mains power that must be available in order for the unit to work.
- The maximum current absorption refers to the current that will trigger the internal safety devices of the unit. It is the maximum current allowed in the unit. This value may never be exceeded; it must be used as a reference for determining the size of the power supply line and the related safety devices (refer to the wiring diagram supplied with the units).

20 INSPECTION, CONVEYANCE, SITING

INSPECTION

On receiving the unit, check that it is perfectly intact: the machine left the factory in perfect conditions; immediately report any signs of damage to the carrier and note them on the Delivery Slip before signing it.

Galletti S.p.A. or its Agent must be promptly notified of the entity of the damage.

The Customer must submit a written report describing every significant sign of damage.

LIFTING AND CONVEYANCE

While the unit is being unloaded and positioned, utmost care must be taken to avoid abrupt or violent manoeuvres. The unit must be handled carefully and gently; avoid using machine components as anchorages when lifting or moving it.

The unit must be lifted using steel pipes $\varnothing 1\frac{1}{2}$ " GAS (minimum thickness 3 mm) inserted through the eyebolts provided on the base frame).

The pipes, which must project at least 300mm on every side, will be slung with ropes of equal length and secured to the lifting hook (apply stops at the end of the pipes to prevent the weight from causing the rope to slip off the pipe).

Use ropes or belts whose length exceeds the machine height and place spacer boards and bars on the top of the unit to avoid damaging the sides and upper part of the unit itself.



WARNING: In all lifting operations make sure that the unit is securely anchored in order to prevent accidental falls or overturning.

UNPACKING

The packing must be carefully removed to avoid the risk of damaging the unit. Different packing materials are used: wood, cardboard, nylon etc. It is recommended to keep them separate and deliver them to authorised waste disposal or recycling facilities in order to minimise their environmental impact.

If the unit is equipped with one or more pumps and a tank, packed inside it you will find the expansion tank, which should be fixed to the pump inlet pipe where a sealed "TEE" connection is provided, or on the tank itself. Remove the cap and screw in the expansion tank (operation to be performed by qualified personnel) before filling the water circuit and starting the machine

SITING

You should bear in mind the following aspects when choosing the best site for installing the unit and the relative connections:

- size and origin of water pipes;
- location of power supply;
- accessibility for maintenance or repairs;
- solidity of the supporting surface;
- ventilation of the air-cooled condenser and necessary clearance;
- direction of prevalent winds: avoid positioning the unit in such a way that the prevalent winds favour the backflow of air to the condenser coils; a speed of 8 m/s (28.8 km/h) already generates a sufficient stagnation pressure to guarantee 60% of the nominal air flow rate. [In situations where the action of air currents is inevitable and there is a simultaneous presence of temperatures below - 5°C, the control of condensation for low outdoor temperatures must be of the flooding type or with capacity control routine of the condensing exchanger -contact the technical department for further details]
- possible reverberation of sound waves.
- avoid the possibility of air bypasses between the outlet and intake, if the latter are positioned too close together.

ALL MODELS BELONGING TO THE LCC SERIES ARE DESIGNED AND BUILT FOR INDOOR INSTALLATION OR INSTALLATIONS IN SITES SHELTERED FROM BAD WEATHER CONDITIONS OR SPRAYS OF WATER.

It is a good idea to provide a supporting base of adequate dimensions. This precaution becomes an imperative when the unit is to be sited on unstable ground.

It is advisable to place a rigid rubber strip between the base frame and the supporting surface.

Whenever more effective insulation is required, it is recommended to use rubber or spring vibrating-damping supports (optional).

The figure below shows the holes in the base through which lifting pipes (diam. 1 1/2" GAS) can be inserted and the vibration-damping feet can be fixed. Mounting centre distances are shown on the dimensional drawing of units.

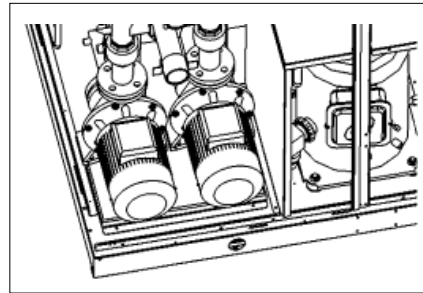

In the case of installation on roofs or intermediate storeys, the unit, pipes and air intake/outlet ducts must be insulated from walls and ceilings by placing rigid rubber joints in between and using supports that are not rigidly anchored to the walls.

If the unit is to be installed in proximity to private offices, bedrooms or areas where noise levels must be kept down, it is advisable to conduct a thorough analysis of the sound field generated and verify its compatibility with the local laws in force.

21 INSTALLATION CLEARANCE REQUIREMENTS

It is of fundamental importance to ensure an adequate volume of air both on the intake and outlet sides of the condenser coils; it is highly important to prevent the air delivered from being re-aspirated as this may impair the performance of the unit or even cause an interruption in normal operation. For this reason it is necessary to guarantee the following clearances (see figure on this page):

back side: 0 metres, the unit may be applied directly on the intake hole on the wall or ducted on the coil side, at both the air inlet and outlet (if the air inlet/outlet are on the rear, avoid the possibility of air bypassing when they are positioned too close together).

- electric board side/plumbing connections: min. 1.5 metres to guarantee access for inspection and/or maintenance of cooling components
- right/left side: min. 1 metre to guarantee access to tank, pumps and cooling components, also from the side.
- top side: there must be no obstacle to air flow (in case of air outlet from above).

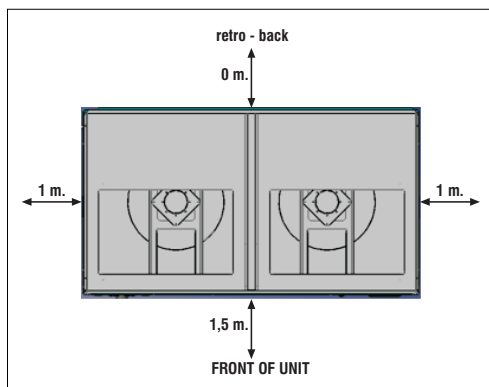

22 LCC FRAME 1 OVERALL DIMENSIONS

Dimensions in mm

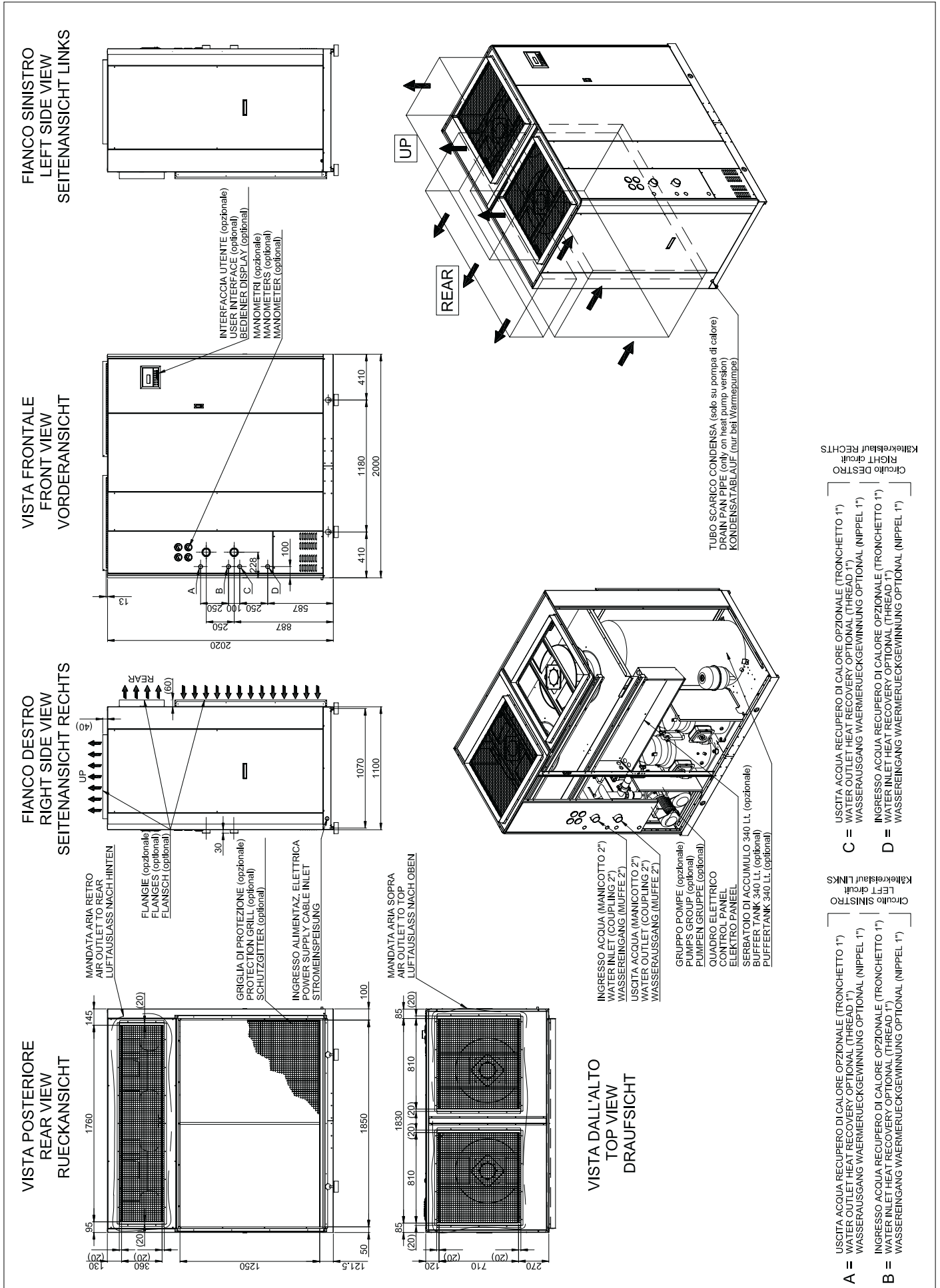

22 LCC FRAME 2 OVERALL DIMENSIONS

Dimensions in mm

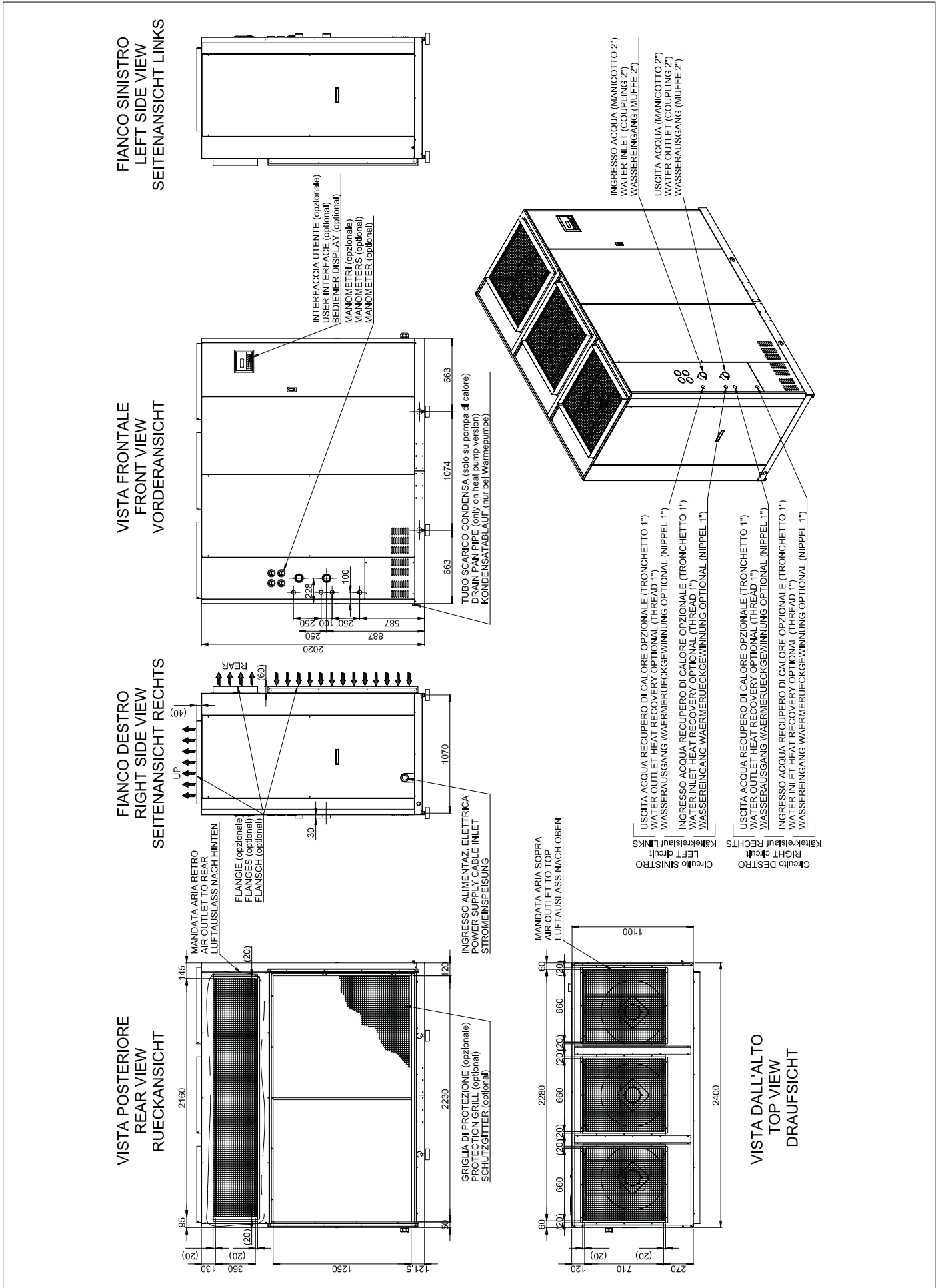

22 LCC FRAME 3 OVERALL DIMENSIONS

Dimensions in mm

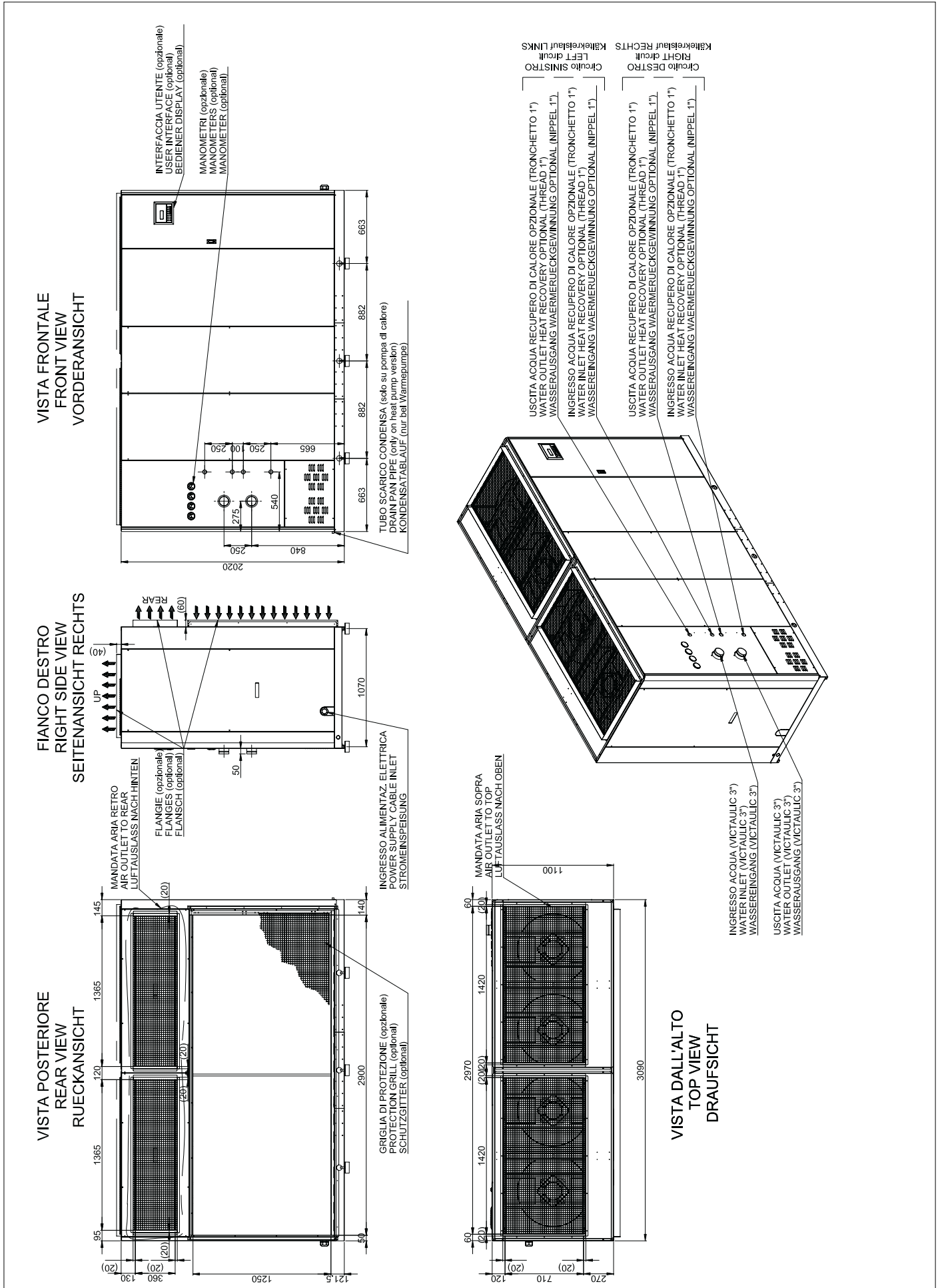

22 OVERALL DIMENSIONS

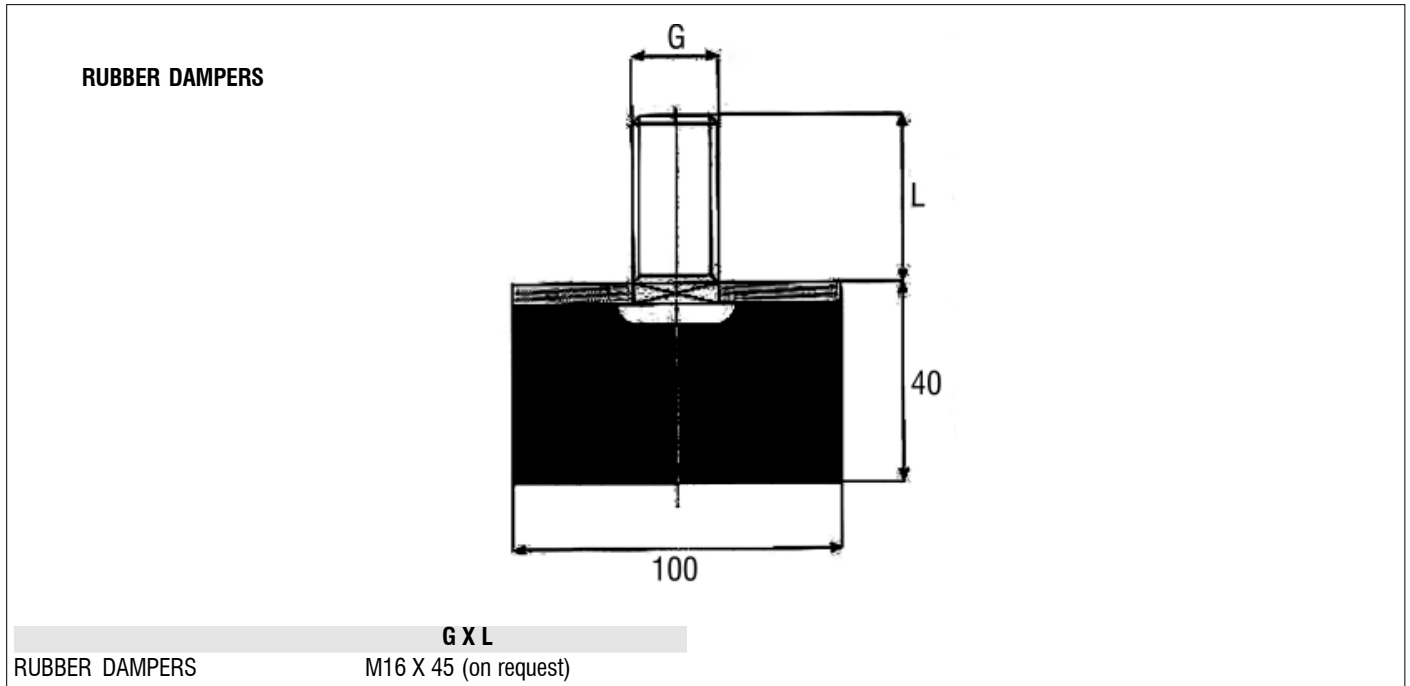

23 WEIGHTS

MODEL		050 CS	060 CS	070 CS	080 CS	090 CS	105 CS	115 CS	130 CS	145CS	160CS
Weight (w/o heat pump and w/o tank)	[kg]	758	776	781	825	943	983	1340	1340	1376	1421
Weight (1 pump and empty tank)	[kg]	938	956	961	1005	1194	1234	1613	1613	1649	1694
Weight (2 pumps and empty tank)	[kg]	994	1013	1019	1065	1266	1308	1710	1710	1748	1796
MODEL		050 CL	060 CL	070 CL	080 CL	090 CL	105 CL	115 CL	130 CL	145 CL	160 CL
Weight (w/o heat pump and w/o tank)	[kg]	771	792	805	849	972	1006	1402	1402	1441	1486
Weight (1 pump and empty tank)	[kg]	951	972	985	1029	1223	1257	1675	1675	1714	1759
Weight (2 pumps and empty tank)	[kg]	1008	1030	1044	1091	1296	1332	1776	1776	1817	1865
MODEL		050 HS	060 HS	070 HS	080 HS	090 HS	105 HS	115 HS	130 HS	145 HS	160 HS
Weight (w/o heat pump and w/o tank)	[kg]	780	798	813	855	991	1046	1388	1388	1429	1474
Weight (1 pump and empty tank)	[kg]	960	978	993	1035	1242	1297	1661	1661	1702	1747
Weight (2 pumps and empty tank)	[kg]	1018	1037	1053	1097	1317	1375	1761	1761	1804	1852
MODEL		050 HL	060 HL	070 HL	080 HL	090 HL	105 HL	115 HL	130 HL	145 HL	160 HL
Weight (w/o heat pump and w/o tank)	[kg]	790	808	823	865	1002	1050	1442	1442	1482	1527
Weight (1 pump and empty tank)	[kg]	970	988	1003	1045	1253	1301	1715	1715	1755	1800
Weight (2 pumps and empty tank)	[kg]	1028	1047	1063	1108	1328	1379	1818	1818	1860	1908
MODEL		050 FS	060 FS	070 FS	080 FS	090 FS	105 FS	115 FS	130 FS	145 FS	160 FS
Weight (w/o heat pump and w/o tank)	[kg]	861	879	884	928	1080	1120	1506	1506	1542	1587
Weight (1 pump and empty tank)	[kg]	1041	1059	1064	1108	1331	1371	1779	1779	1815	1860
Weight (2 pumps and empty tank)	[kg]	1103	1123	1128	1174	1411	1453	1886	1886	1924	1972
MODEL		050 FL	060 FL	070 FL	080 FL	090 FL	105 FL	115 FL	130 FL	145 FL	160 FL
Weight (w/o heat pump and w/o tank)	[kg]	893	911	916	960	1125	1165	1563	1563	1599	1644
Weight (1 pump and empty tank)	[kg]	1073	1091	1096	1140	1376	1416	1836	1836	1872	1917
Weight (2 pumps and empty tank)	[kg]	1137	1156	1162	1208	1459	1501	1946	1946	1984	2032



40010 Bentivoglio (BO)
Via Romagnoli, 12/a
Tel. 051/8908111
Fax 051/8908122
www.galletti.it